

A Division of Systems, LLC

**DLM**  
**DOCK LEVELER**  
**MANUFACTURING**

# LHD Series

## Dock Leveler

### Owner's/User's Manual



**DLM** • Division of Systems, LLC • W194 N11481 McCormick Drive • Germantown, WI 53022  
800.643.5424 • fax: 262.255.5917 • [www.dlminc.net](http://www.dlminc.net) • [techservices@loadingdocksystems.com](mailto:techservices@loadingdocksystems.com)

Printed in U.S.A.  
© 2020 Systems, LLC - All Rights Reserved

Manual No. 4111-0023  
Aug. 2020

# Table of Contents

	Page
<b>Precautions</b>	
Recognize Precautionary Information .....	1
General Operational Precautions .....	1
Operational Precautions .....	2
Safety Decals.....	4
Placard .....	5
Owner's/User's Responsibilities .....	6
<b>Introduction</b>	
General Information.....	8
Component Identification.....	9
<b>Installation</b>	
Installation Precautions .....	10
Prepare Pit.....	12
Prepare Dock Leveler .....	13
Install Dock Leveler .....	14
Install Control Panel and Wiring .....	20
Put New Dock Leveler Into Service.....	24
<b>Operation</b>	
Operational Precautions .....	25
Operating Instructions .....	26
Optional Equipment.....	27
<b>Maintenance</b>	
Maintenance Precautions.....	28
Periodic Maintenance .....	30
<b>Adjustments</b>	
Adjust Main Pressure Relief .....	32
Adjust Lip Function .....	33
<b>Troubleshooting</b>	
Troubleshooting.....	34
<b>Parts</b>	
Danfoss Control Box .....	38
Optional Electrical Parts (Control Box) .....	39
Frame and Platform .....	40
Hydraulic Components.....	42
Weather Seals .....	44
Toe Guards .....	46
<b>Miscellaneous</b>	
Customer Information .....	49
Warranty.....	Back Cover

# PRECAUTIONS

## Recognize Precautionary Information

### Safety-Alert Symbol



The Safety-Alert Symbol is a graphic representation intended to convey a safety message without the use of words. When you see this symbol, be alert to the possibility of death or serious injury. Follow the instructions in the safety message panel.

### **DANGER**

The use of the word DANGER signifies the presence of an extreme hazard or unsafe practice which will most likely result in death or severe injury.

### **WARNING**

The use of the word WARNING signifies the presence of a serious hazard or unsafe practice which could result in death or serious injury.

### **CAUTION**

The use of the word CAUTION signifies possible hazard or unsafe practice which could result in minor or moderate injury.

### **NOTICE**

The use of the word NOTICE indicates information considered important, but not hazard-related, to prevent machine or property damage.

## **SAFETY INSTRUCTIONS**

Indicates a type of safety sign, or separate panel on a safety sign, where safety-related instructions or procedures are described.

## General Operational Precautions



Read and understand the Owner's/User's Manual and become thoroughly familiar with the equipment and its controls before operating the dock leveler.

Never operate a dock leveler while a safety device or guard is removed or disconnected.

Never remove DANGER, WARNING, or CAUTION signs, Placards or Decals on the equipment unless replacing them.

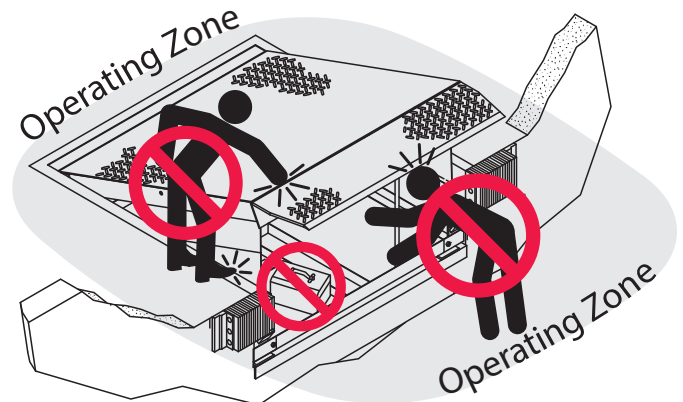

Figure 1

Do not start the equipment until all unauthorized personnel in the area have been warned and have moved outside the operating zone (see Figure 1).

Remove any tools or foreign objects from the operating zone before starting.

Keep the operating zone free of obstacles that could cause a person to trip or fall.



**WARNING:** This product can expose you to chemicals including lead, which are known to the State of California to cause cancer or birth defects or other reproductive harm. For more information go to [www.P65Warnings.ca.gov](http://www.P65Warnings.ca.gov)

# PRECAUTIONS

## Operational Precautions



Learn the safe way to operate this equipment. Read and understand the manufacturer's instructions. If you have any questions, ask your supervisor.

### **DANGER**



Stay clear of dock leveling device when transport vehicle is entering or leaving area.



Do not move or use the dock leveling device if anyone is under or in front of it.



Keep hands and feet clear of pinch points. Avoid putting any part of your body near moving parts.

### **WARNING**



Chock/restrain all transport vehicles. Never remove the wheel chocks or release the restraining device until loading or unloading is finished, and transport driver has been given permission to drive away.



Do not use a broken or damaged dock leveling device or restraining device. Make sure proper service and maintenance procedures have been performed before using.

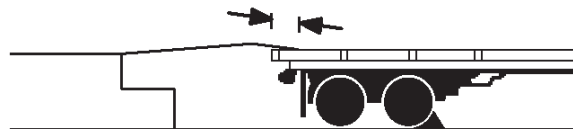

Make sure lip overlaps onto transport vehicle bed at least 4 in. (102 mm).

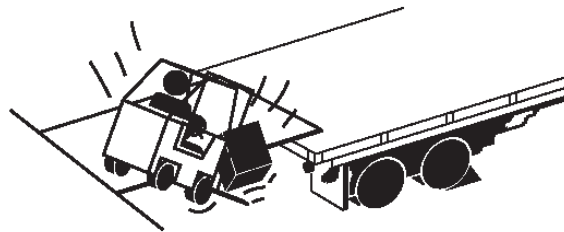

Keep a safe distance from both side edges.

Operational Precautions

**! WARNING**



Do not use dock leveling device if transport vehicle is too high or too low.

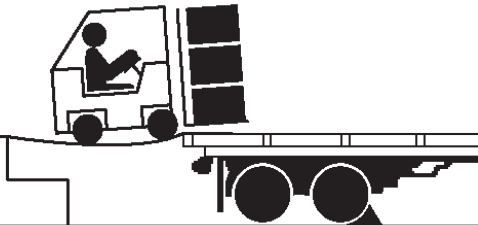

Do not overload the dock leveling device.

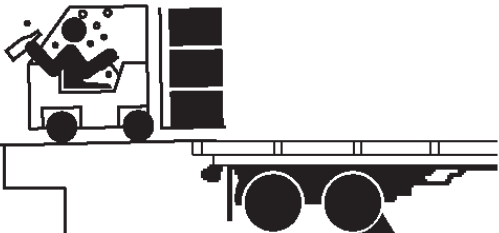

Do not operate any equipment while under the influence of alcohol or drugs.

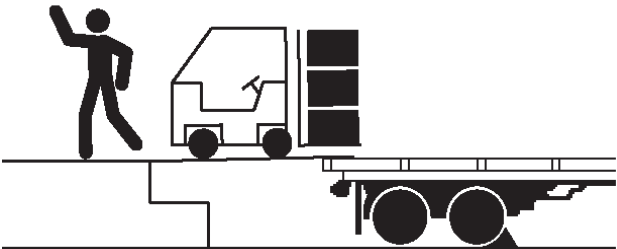

Do not leave equipment or material unattended on dock leveling device.

# PRECAUTIONS

## Safety Decals



1751-0329



1751-0330 Two positions one on top of each fork pocket.

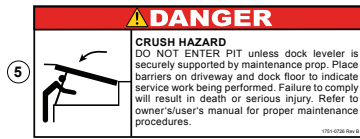

1751-0726

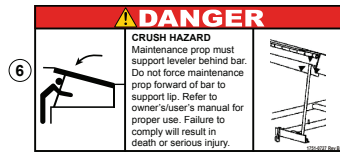

1751-0727



1751-0729

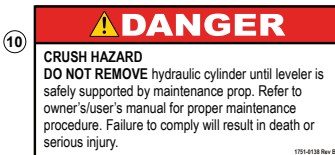

1751-0138

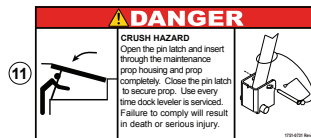

1751-0731

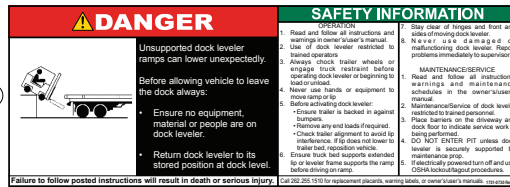

1751-0730

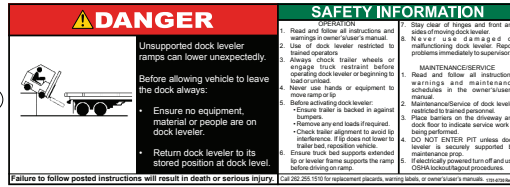

1751-0730

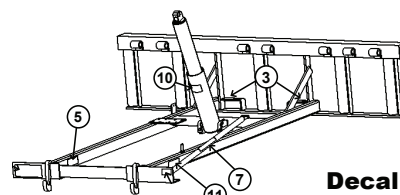
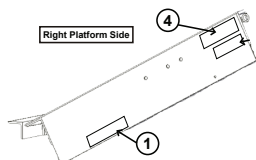
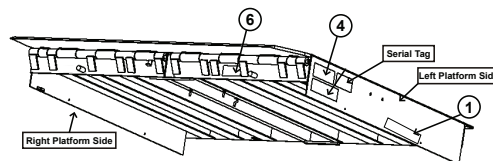



Figure 2

Decal Placement for LHD Series

## Placard



# DANGER

## OPERATING INSTRUCTIONS

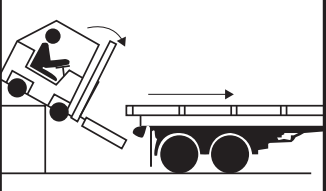

- Read and follow all instructions, warnings, and maintenance schedules in the manual and on placards.
- Operation and servicing of dock leveler is restricted to authorized personnel.

- Always chock transport vehicle wheels or engage vehicle restraint and set parking brakes before operating dock leveler or beginning to load or unload.
- Before activating dock leveler, check to make sure the transport vehicle is positioned squarely against dock bumpers. Ensure lip will avoid contact with transport vehicle frame, sides and cargo during dock leveler activation. If contact is likely or observed, reposition transport vehicle.
- Ensure the transport vehicle floor supports extended lip or the leveler frame (lip keepers or below dock endload supports) supports the ramp before driving on ramp.
- Stay clear of hinges and front and sides of moving dock leveler.
- Never use hands or equipment to move the ramp or lip.
- Never use damaged or malfunctioning dock leveler. Report problems immediately to supervisor.
- Always store dock leveler and remove people, material, and equipment from ramp before vehicle leaves the dock.
- DO NOT ENTER PIT unless dock leveler is securely supported and proper lockout/tagout procedures have been completed. See "Maintenance Precautions" in Owner's/User's Manual.

**FAILURE TO FOLLOW THESE INSTRUCTIONS WILL RESULT IN DEATH OR OTHER SERIOUS INJURY.**



Scan to view our owner's/user's manuals online.  
[www.LoadingDockSystems.com](http://www.LoadingDockSystems.com)  
**1.800.643.5424**  
 Call for additional placards, or manuals, or with questions regarding proper use, maintenance, and repair of dock leveler.



WARNING: CANCER AND REPRODUCTIVE HARM  
[www.P65Warnings.ca.gov](http://www.P65Warnings.ca.gov)



1751-0874 Rev D

## POWERED DOCK LEVELERS

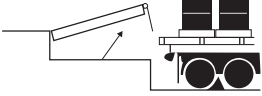

**NORMAL OPERATION**

1. Raise the platform by Pressing and holding the RAISE button.

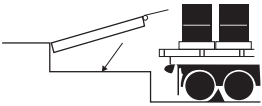

2. Hold the RAISE button until the lip is fully extended, then release the RAISE button. The platform will lower until lip is resting on the transport vehicle.

**STORING LEVELER**

1. Press the RAISE button until the lip is completely folded. When the lip is folded, release the RAISE button. The platform will lower returning to the cross-traffic position.

**BELOW DOCK ENDLOADING**

- **(AIR POWERED ONLY)** Press and hold the RAISE button until the leveler is 12" above dock level. Pull the below dock level chain until the leveler lowers the full below dock position.
- **(HYDRAULIC ONLY)** Press and hold the RAISE button until the leveler is fully raised. As the lip starts to extend, release the RAISE button. The leveler will lower to the below dock position provided the lip extension allows the lip to clear the lip keepers.
- **(HYDRAULIC WITH INFINITE LIP CONTROL)** If equipped, raise the platform by Pressing and holding the RAISE button. When the lip is just above the lip keepers, simultaneously Press and hold the RAISE button and the LIP OUT button until lip has extended beyond the lip keepers. Release both buttons.

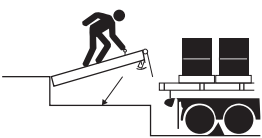

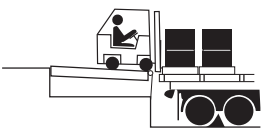

**NOTE: If equipped, Pressing E-STOP button will stop platform from lowering.**

1751-0874

# OWNER'S/USER'S RESPONSIBILITIES

---

- 1) The manufacturer shall provide to the initial purchaser and make the following information readily available to the owners/users and their agents, all necessary information regarding Safety Information, Operation, Installation and Safety Precautions, Recommended Initial and Periodic Inspections Procedures, Planned Maintenance Schedule, Product Specifications, Troubleshooting Guide, Parts Break Down, Warranty Information, and Manufacturers Contact Information, as well as tables to identify the grade(slope) for all variations of length or configuration of the dock leveling device and information identifying the maximum uncontrolled drop encountered when sudden removal of support while in the working range of the equipment.
- 2) When selecting loading dock safety equipment, it is important to consider not only present requirements but also future plans and any possible adverse conditions, environmental factors or usage. The owners/users shall provide application information to the manufacturer to receive recommendations on appropriate equipment specifications and capacity.
- 3) The owner/user must see all nameplates, placards, decals, instructions and posted warnings are in place and legible and shall not be obscured from the view of the operator or maintenance personnel for whom such warnings are intended for. Contact manufacturer for any replacements.
- 4) Dock leveling devices may become hazardous if the manufacturer's instructions regarding modifications or adjustments are not followed. Modifications or alterations of dock leveling devices shall only be made with prior written approval from the original manufacturer. These changes shall be in conformance with all applicable provisions of the MH30.1 standard and shall also satisfy all safety recommendations of the original equipment manufacturer of the particular application.
- 5) The owner/user should recognize the inherent dangers of the interface between the loading dock and the transport vehicle. The owner/ user should, therefore, train and instruct all operators in the safe operation and use of the loading dock equipment in accordance with manufacturer's recommendations and industry standards. Effective operator training should also focus on the owner's/user's company policies, operating conditions and the manufacturer's specific instructions provided with the dock leveling device. Maintaining, updating and retraining all operators on safe working habits and operation of the equipment, regardless of previous experience, should be done on a regular basis and should include an understanding and familiarity with all functions of the equipment. Owners/users shall actively maintain, update and retrain all operators on safe working habits and operations of the equipment.
- 6) An operator training program should consist of, but not necessarily be limited to, the following:
  - a) Select the operator carefully. Consider the physical qualifications, job attitude and aptitude.
  - b) Assure that the operator reads and fully understands the complete manufacturer's owners/users manual.
  - c) Emphasize the impact of proper operation upon the operator, other personnel, material being handled, and equipment. Cite all rules and why they are formulated.
  - d) Describe the basic fundamentals of the dock leveling device and components design as related to safety, e.g., mechanical limitation, stability, functionality, etc.
  - e) Introduce the equipment. Show the control locations and demonstrate its functions. Explain how they work when used properly and maintained as well as problems when they are used improperly.
  - f) Assure that the operator understands the capacity rating, nameplate data, placards and all precautionary information appearing on the dock leveling device.
  - g) Supervise operator practice of equipment.
  - h) Develop and administer written and practical performance tests. Evaluate progress during and at completion of the course.
  - i) Administer periodic refresher courses. These may be condensed versions of the primary course and include on-the-job operator evaluation.



# OWNER'S/USER'S RESPONSIBILITIES

---

- 7) Loading dock safety equipment should never be used outside of its vertical working range, or outside the manufacturer's rated capacity. It shall also be compatible with the loading equipment and other conditions related to dock activity. Please consult the manufacturer if you have any questions as to the use, vertical working range or capacity of the equipment. Only properly trained and authorized personnel should operate the equipment.
- 8) It is recommended that the transport vehicle is positioned as close as practical to the dock leveling device and in contact with both bumpers. When an industrial vehicle is driven on or off a transport vehicle during loading and unloading operations, the transport vehicle parking brakes shall be applied and wheel chocks or a restraining device that provides equal or better protection of wheel chocks shall be engaged. Also, whenever possible, air-ride suspension systems should have the air exhausted prior to performing said loading and unloading operations.
- 9) When goods are transferred between the loading dock and a trailer resting on its support legs/ landing gear instead of a tractor fifth wheel or converter dolly, it is recommended that an adequate stabilizing device or devices shall be utilized at the front of the trailer.
- 10) In order to be entitled to the benefits of the standard product warranty, the dock safety equipment must have been properly installed, maintained and operated in accordance with all manufacturer's recommendations and/ or specified design parameters and not otherwise have been subject to abuse, misuse, misapplication, acts of nature, overloading, unauthorized repair or modification, application in a corrosive environment or lack of maintenance. Periodic lubrication, adjustment and inspection in accordance with all manufacturers' recommendations are the sole responsibility of the owner/user.
- 11) Manufacturer's recommended maintenance and inspection of all dock leveling devices shall be performed in conformance with the following practices: A planned maintenance schedule program must be followed, only trained and authorized personnel shall be permitted to maintain, repair, adjust and inspect dock leveling devices, and only the use of original equipment manufacturer parts, manuals, maintenance instructions, labels, decals and placards or their equivalent. Written documentation of maintenance, replacement parts or damage should be kept. In the event of damage, notification to the manufacturer is required.
- 12) Loading dock devices that are structurally damaged or have experienced a sudden loss of support while under load, such as might occur when a transport vehicle is pulled out from under the dock leveling device, shall be removed from service, inspected by a manufacturer's authorized representative, and repaired or replaced as needed or recommended by the manufacturer before being placed back in service.

# INTRODUCTION

---

## General Information



Figure 3

This manual provides current information on the LHD-series dock leveler. Due to ongoing product improvement, some parts may have changed, along with operation and troubleshooting methods. This manual describes these changes where applicable.

The LHD-series dock leveler comes equipped with an electrical control panel, which allows push button operation of the dock leveler functions. When combining a LHD-series dock leveler with a DLM hydraulic vehicle restraint, the control panel will allow for operation of both units in the same control panel.

Each LHD-series dock leveler unit has been factory tested to ensure satisfactory operation.

To illustrate which connections are to be made in the field at installation, electrical drawings are included with each order or by contacting Systems, LLC Technical Services.

LHD dock levelers are available in the following sizes, weight capacities, and options:

### Width

6 ft (1828.8 mm)  
6-1/2 ft (1981.2 mm)  
7 ft (2133.6 mm)

### Length

6 ft (1828.8 mm)  
8 ft (2438 mm)  
10 ft (3048 mm)

### Capacity (CIR\*)

25,000 lb (11 340 kg)  
35,000 lb (15 876 kg)  
40,000 lb (18 144 kg)

\* CIR (Comparative Industry Rating)

Call DLM to discuss available voltages, phases and options to meet your specific needs.

Technical Service at 800-643-5424 or [techservices@loadingdocksystems.com](mailto:techservices@loadingdocksystems.com)

## Component Identification

Inspect package and all components. Report any missing or damaged items immediately and note on the shipping Bill Of Lading (BOL).

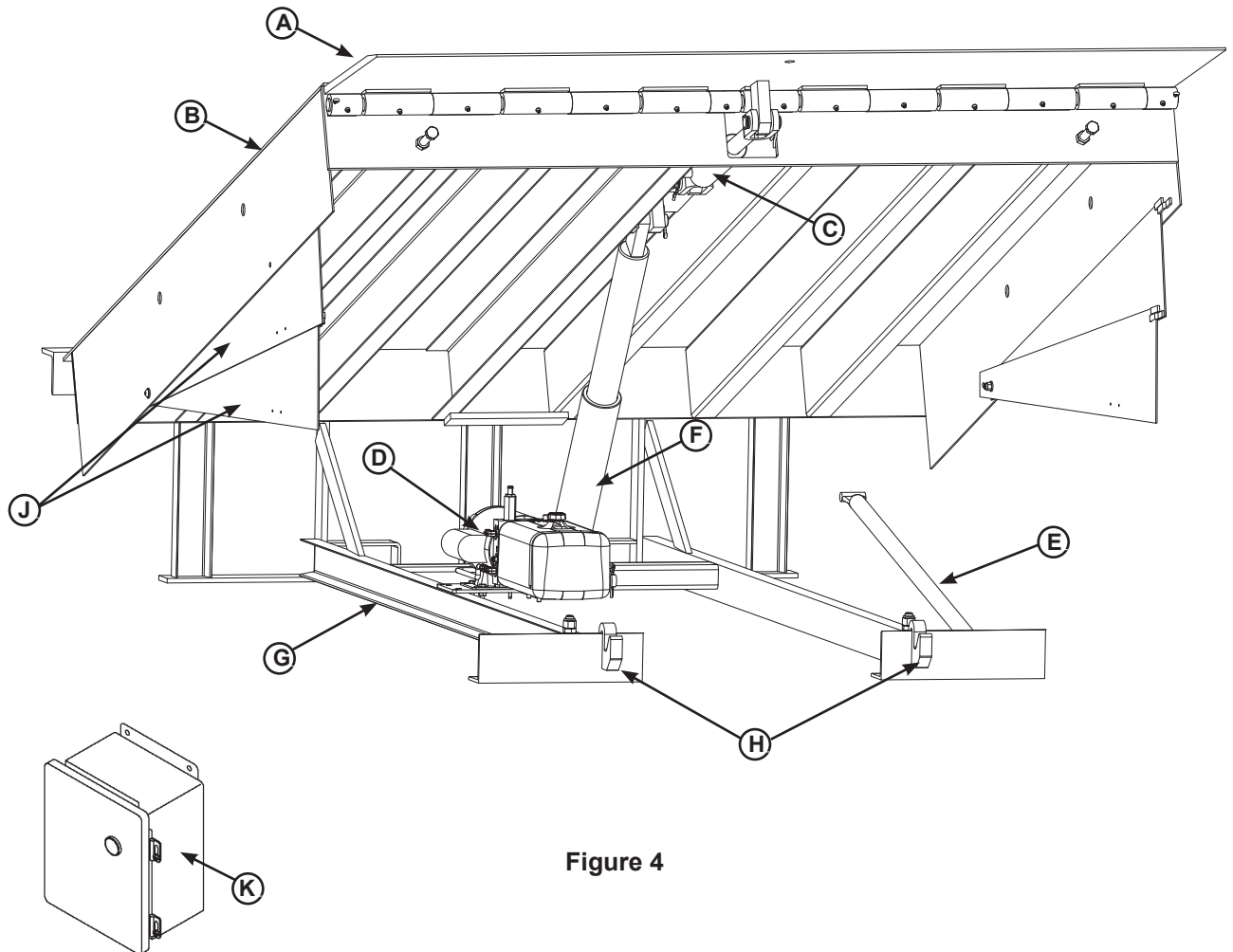

Figure 4

- |                  |                                      |                 |                           |
|------------------|--------------------------------------|-----------------|---------------------------|
| A — Lip          | D — Powerpack (Motor/Pump/Reservoir) | G — Main Frame  | J — Full Range Toe Guards |
| B — Platform     | E — Maintenance Prop                 | H — Lip Keepers | K — Control Box*          |
| C — Lip Cylinder | F — Platform Cylinder                |                 |                           |

\* Control box appearance may vary depending on options.

# INSTALLATION

## Installation Precautions

### **DANGER**

It is recommended and good safety practice to use an additional means to support the dock platform and lip anytime when physically working in front of or under the dock leveler. This additional means may include, but is not limited to a boom truck, fork truck, stabilizing bar or equivalent.

### **WARNING**

Always post safety warnings and barricade the work area at dock level and ground level to prevent unauthorized use of the dock leveler before installation is complete.

A hard hat or other applicable head protection should always be worn when working under or around a dock leveler.

Always stand clear of platform lip when working in front of the dock leveler.

### **WARNING**

DO NOT grind or weld if hydraulic fluid or other flammable liquid is present on the surface to be ground or welded.

DO NOT grind or weld if uncontained hydraulic fluid or other flammable liquid is present. Stray sparks can ignite spills or leaks near the work area. Always clean up the oil leaks and spills before proceeding with grinding or welding.

Always keep a fire extinguisher of the proper type nearby when grinding or welding.

### **CAUTION**

Only trained installation professionals with the proper equipment should install this product.

### **NOTICE**

DO NOT connect the dock leveler electrical wiring and ground connections until all welding has been completed.

DO NOT ground welding equipment to any hydraulic or electrical components of the dock leveler. Always ground welding equipment to the dock leveler frame, NEVER to the platform.

Failure to follow these instructions may damage the motor, hydraulics, wiring, and/or control panel.

### **NOTICE**

DO NOT remove the shipping bands around the dock leveler lip until instructed to do so.

This page intentionally left blank.

# INSTALLATION

## Prepare Pit

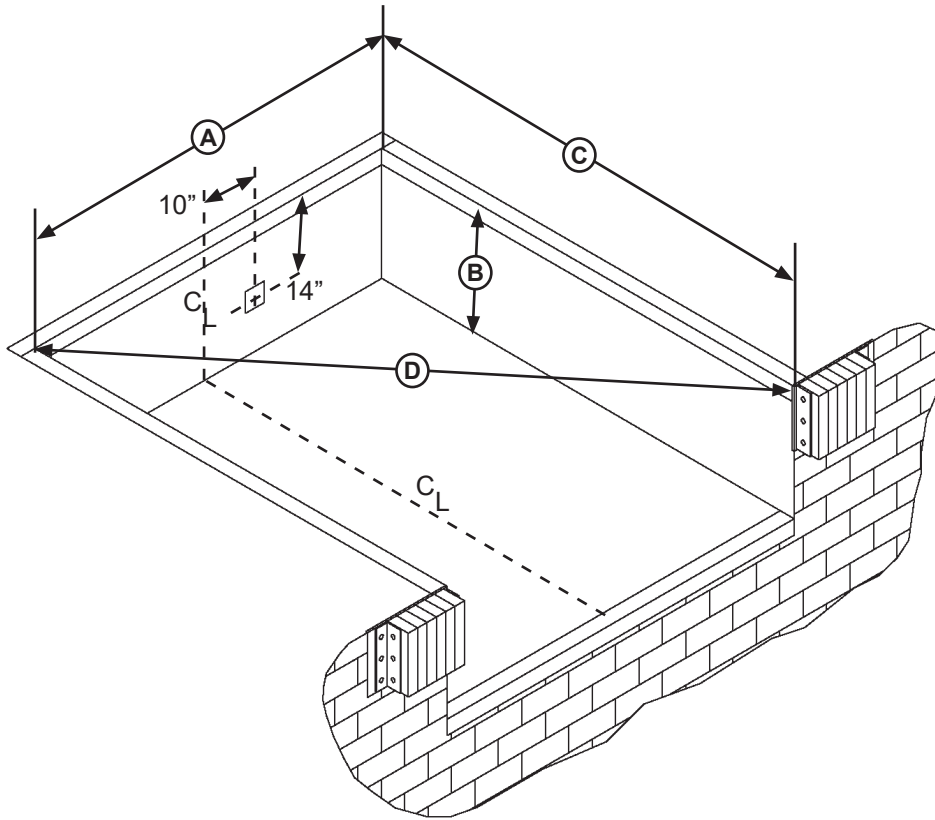

**Figure 5**

**A—Pit Width**  
(Front and Rear)

**B— Dock Floor-to-Pit Floor**  
(All Four Corners)

**C— Pit Length**  
(Both Sides of Pit)

**D— Pit Corner-to-Corner**  
(Top, Bottom, and Both Sides)

Before lowering the dock leveler into the pit, the following must be performed:

1. Remove all debris from the pit and sweep the pit clean.
2. Check the entire dock leveler pit for proper construction according to approved/certified pit drawings. Make sure pit is square by making the following measurements (see Figure 5):
  - Measure pit width distance (**A**) at both front and rear of pit.
  - Measure dock floor-to-pit floor distance (**B**) at all four corners.
  - Measure pit length distance (**C**) at both sides.
  - Measure corner-to-corner (diagonal) distance (**D**) at both sides. Take measurements at dock floor level and at pit floor level.

If any measurement is off by more than 1/8 in. (3.18 mm), contact Systems, LLC Technical Services before proceeding.

3. Make sure the field junction box for the dock leveler is at the correct location per pit diagrams.

## Prepare Dock Leveler

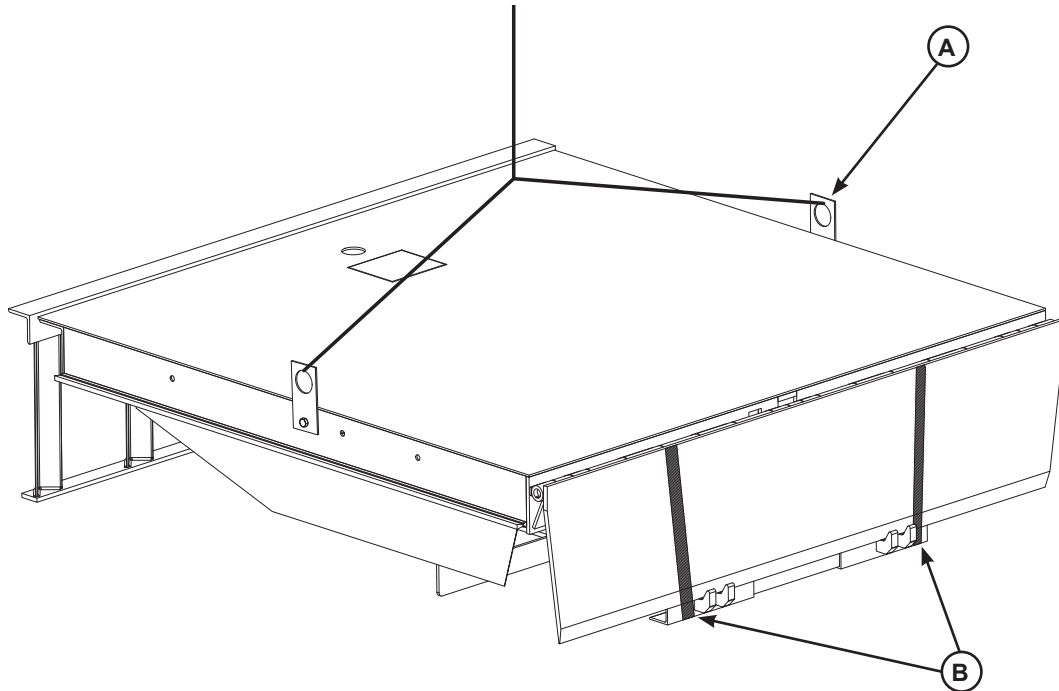

Figure 6

A— Lifting Bracket (2 used)

B — Shipping Bands

Systems, LLC dock levelers are shipped with lifting brackets (A) fastened to the platform side joists, and shipping bands (B) around the platform lip and leveler frame (see Figure 6)

3. Attach lifting chains to lifting brackets (A) and to a lifting device (i.e., hoist or fork truck) having the appropriate lifting capacity and reach.

1. Remove any bumpers and/or control panels that may be banded to the frame of the dock leveler.

4. Remove wood blocks that are attached to the leveler frame before putting the dock leveler into the pit.

### **NOTICE**

DO NOT remove the shipping bands (B) around the platform lip and leveler frame at this time. The shipping bands are needed to hold the leveler together during the installation process.

5. Proceed to “Install Dock Leveler” on Page 14.

**Note:** Overall width of platform and lifting brackets (A) must be kept to a minimum to prevent interference between the lifting brackets and the pit walls as the dock leveler is lowered into the pit.

2. Make sure the mounting hardware of lifting brackets (A) is snug. The brackets should pivot without binding on the mounting cap screw.

### **NOTICE**

DO NOT over-tighten the lifting bracket hardware. Over-tightening can damage the weather seal, if equipped.

# INSTALLATION

## Install Dock Leveler

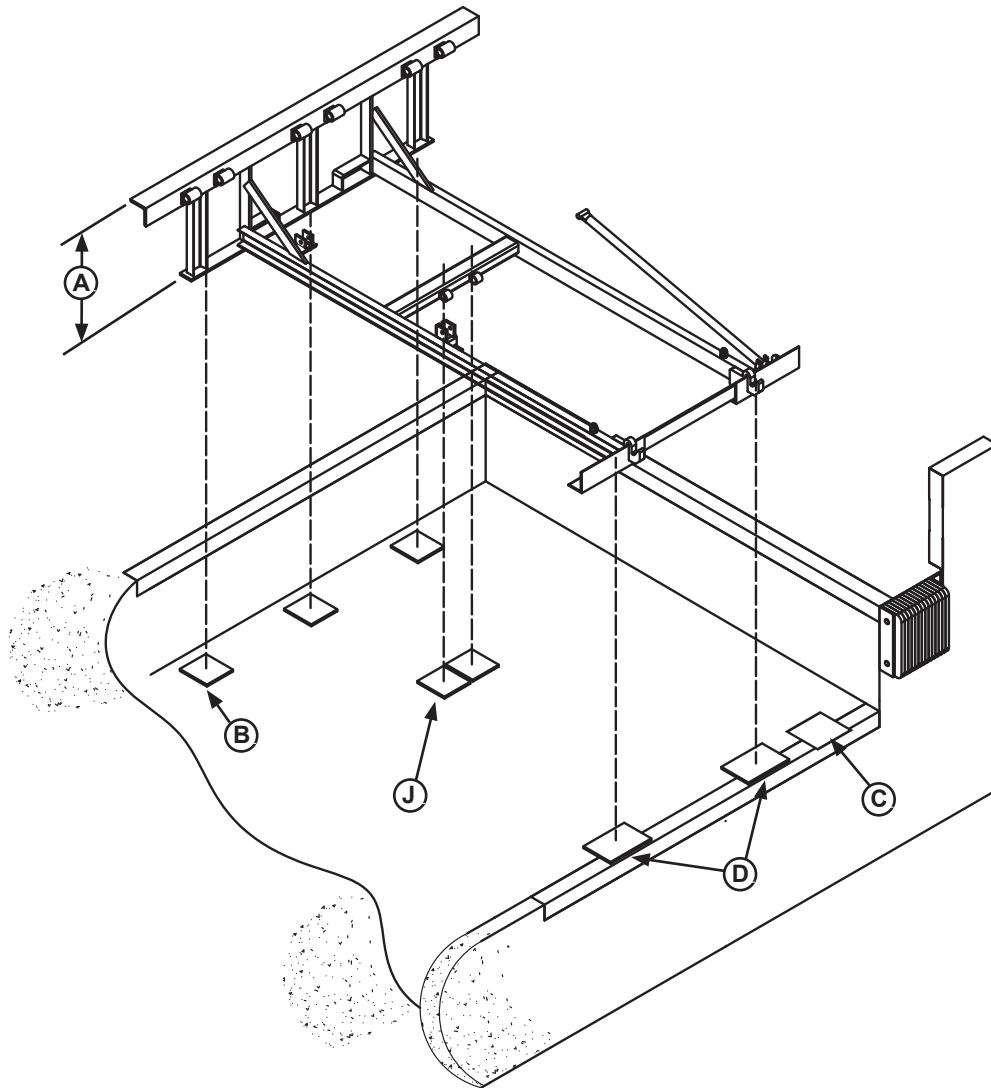

Figure 7

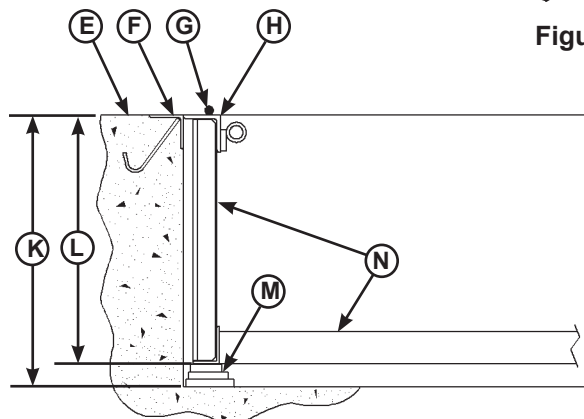

Figure 8

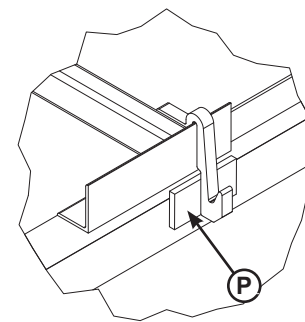

Figure 9

- |  |                                       |  |   |
|--|---------------------------------------|--|---|
| A— Distance (Leveler Frame Height)               | D— Shim Locations (Under Lip Keepers) | H— Rear Hinge Frame Angle                | L— Distance (Top of Shim Stack-to-Dock Floor) |
| B— Shim Locations (Under Rear Vertical Supports) | E— Dock Floor                         | J— Shims Location (Under Hoist Cylinder) | M— Shim Stack                                 |
| C— Shim Location (Under Maintenance Prop)        | F— Rear Pit Curb Angle                | K— Distance (Dock Floor-to-Pit Floor)    | N— Dock Leveler Frame                         |
|  | G— String                             |  | P— Lip Keeper Shim (as required)              |



## Install Dock Leveler (continued)

**Note:** Systems, LLC dock levelers are designed with a nominal 1/2" (12.7 mm) shimming distance to allow for pit inconsistencies.

1. Determine height of shim stack (**M**) for each shim location (**B**) by performing the following:

- a. Measure leveler frame height distance (**A**).
- b. Measure dock floor-to-pit floor distance (**K**) at each shim location (**B**). Write down the dimensions obtained at each location.
- c. Subtract distance (**A**) from distance (**K**) to obtain the shim height. Repeat for each shim location.

2. Using the results obtained in step 1, create the individual shim stacks on the pit floor at location (**B**). Build each shim stack (**M**) with the top shim having a minimum size of 4" x 4" (101.6 mm x 101.6 mm) and each successive lower shim being larger so the shims can be welded together using a fillet weld. If using offset method, make sure load is over center of shim stack, NOT over the edge. DO NOT use straight method. See Figure 10.

## NOTICE

The minimum size of the shim that contacts the leveler frame (i.e. the top shim of each shim stack) must be at least 4" x 4" (101.6 mm x 101.6 mm) to support the full width of the frame rail and to provide a shelf for a fillet weld.

Use the thickest shim stock possible for stability and weld penetration purposes. DO NOT use multiple layers of 1/8 in. (3.18 mm) or thinner shim stock.

**Note:** To assist in obtaining an accurate measurement of distance (**L**), use a string (**G**) pulled tight across the pit opening, directly over the shim locations.

3. Verify that each shim stack is at the correct height by measuring distance (**L**) [top of shim stack (**M**) to dock floor]. Distance (**L**) must equal the dock leveler height (**A**).

4. Put a 1/4 in. (6.6 mm) thick shim at locations (**C** and **D**).

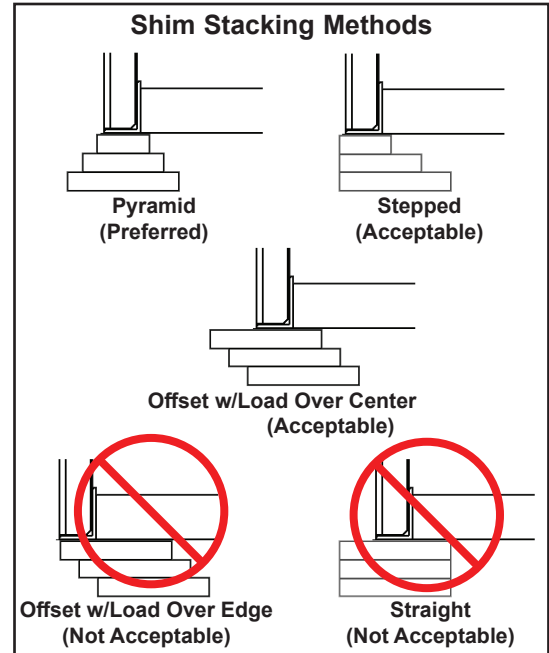

Figure 10

**Note:** A 1/4" (6.6 mm) thick shim at locations (**C** and **D**) are used only as a starting point. The final shim stack height will be determined after dock leveler is lowered into the pit.

5. Using an appropriate lifting device connected to the lifting brackets, lower dock leveler into the pit so rear hinge frame angle (**H**) is tight against rear pit curb angle (**F**) across full width of the leveler frame.

## WARNING

The dock leveler is heavy. Use a lifting device and chains with the appropriate lifting capacity and reach.

Always use the lifting brackets provided with the unit whenever lowering or lifting a dock leveler into or out of a pit.

6. Allow rear of dock leveler to rest on the rear shims while keeping the front of the dock leveler level with the dock floor.

7. Add shims at front shim locations (**C** and **D**) so front of dock leveler will stay level with dock floor when leveler is resting fully on shims.

**Note:** Hoist cylinder and maintenance prop will be shimmed later in the install process.

# INSTALLATION

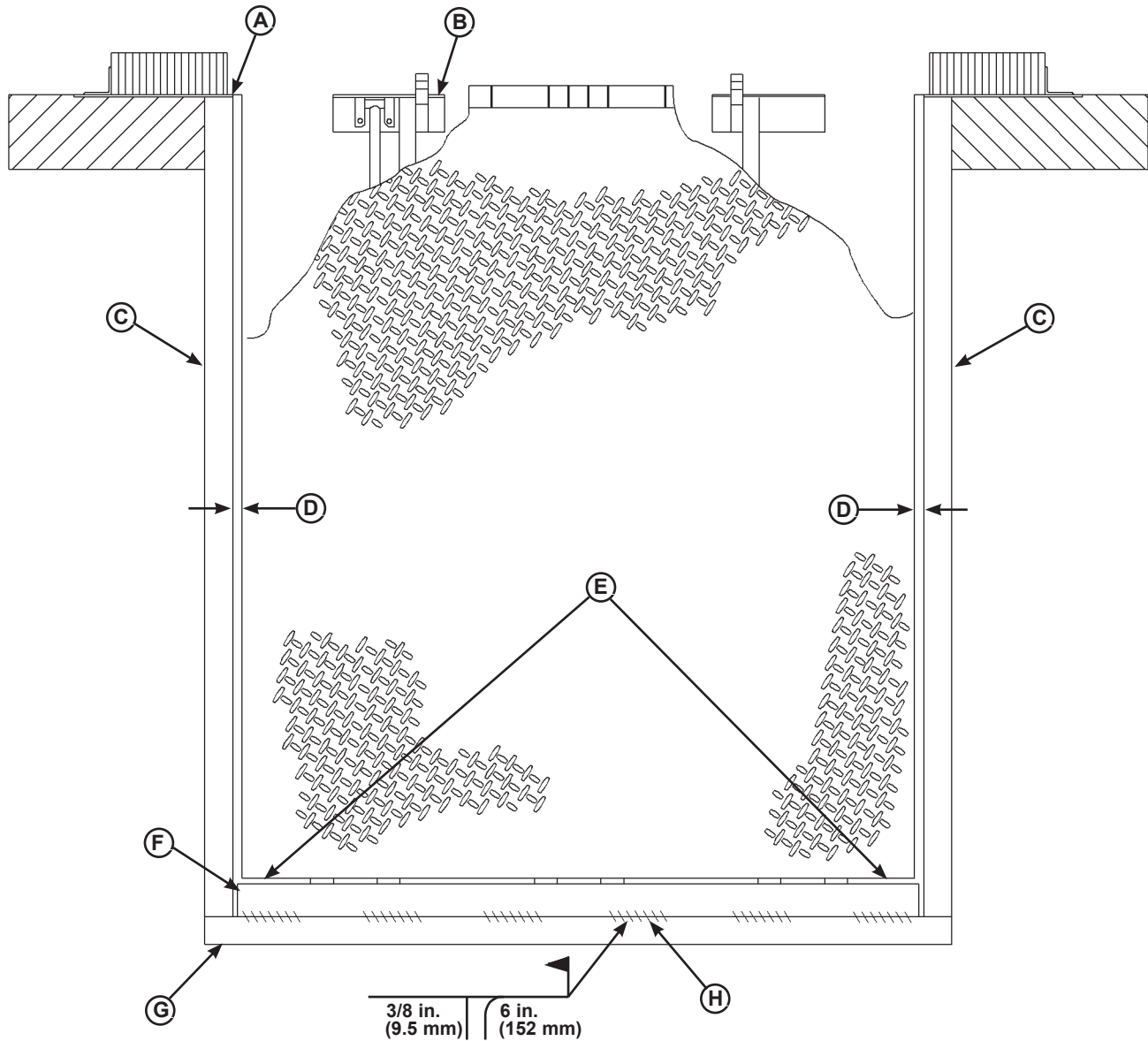

**Figure 11**

- |                       |                                  |                           |   |
|-----------------------|----------------------------------|---------------------------|---|
| A— Front of Dock Pit  | C— Side Pit Curb Angle           | E— Pry Locations          | G— Rear Pit Curb Angle                        |
| B— Dock Leveler Frame | D— Gap [3/4 in. (19 mm) Minimum] | F— Rear Hinge Frame Angle | H— Flare Bevel Weld, Typical (To Fit Spacing) |

8. With rear hinge frame angle (F) tight against rear pit curb angle (G), perform/check the following:

- Pry between the platform and rear hinge frame angle at locations (E) to make sure rear edge of platform is parallel to the rear hinge frame angle (F).
- Gap (D) must exist equally along both sides of leveler so weather seal (if equipped) will not bind during dock leveler operation.

9. If gap (D) cannot be obtained equally at both sides of leveler, grind or add material at the rear edge of rear hinge frame angle (F) as needed.

10. Allow the dock leveler to rest fully on the shim stacks. Check that a smooth and level transition exists between the dock floor and the dock leveler platform. Add or remove shims as necessary until a smooth transition is obtained.

11. If leveler cannot be squared and/or made level as instructed in steps 8-10, contact Systems, LLC Technical Services.

## Install Dock Leveler (continued)

### NOTICE

DO NOT weld continuously along the full length of the rear hinge frame angle. This can put unnecessary stress on the leveler components, causing the leveler to malfunction and shorten the lifespan of the affected components.

12. With the rear hinge frame angle (**F**) tight against the rear pit curb angle (**G**), weld the rear hinge frame angle (**F**) to the rear pit curb angle (**G**) using a 3/8 in. (9.5 mm) flare bevel skip weld — each weld being 6 in. (152 mm) long.

- Start at each end with a 6 in. (152 mm) long weld. Space all the other welds out evenly, leaving approximately 6 in. (152 mm) space between each weld.

**Note:** Figure 11 shows a typical weld pattern. The weld pattern will vary slightly depending on size of dock leveler.

13. Weld front of dock leveler frame (**B**) to shims located under the keepers, then weld the shims to the front pit curb steel.

14. With leveler welded into place, remove the shipping bands from around lip and leveler frame.

15. Using an external lifting device (i.e. crane or fork truck) attached to the platform lifting brackets, slowly raise the platform. Check for binding as platform is being raised.

16. If binding occurs, lower the platform. Reposition leveler and/or add or remove shims as necessary. Slowly raise platform again. If platform still binds, contact Systems, LLC Technical Services for further instructions.

### WARNING

If the platform is raised using an external lifting device or the hydraulic system is opened to atmosphere, air will enter into the hydraulic system.

Whenever this happens, always cycle the leveler at least 4 times using the leveler's own hydraulic power system before allowing the leveler to be put into service. This is to make sure all air is purged from the hydraulic cylinders.

# INSTALLATION

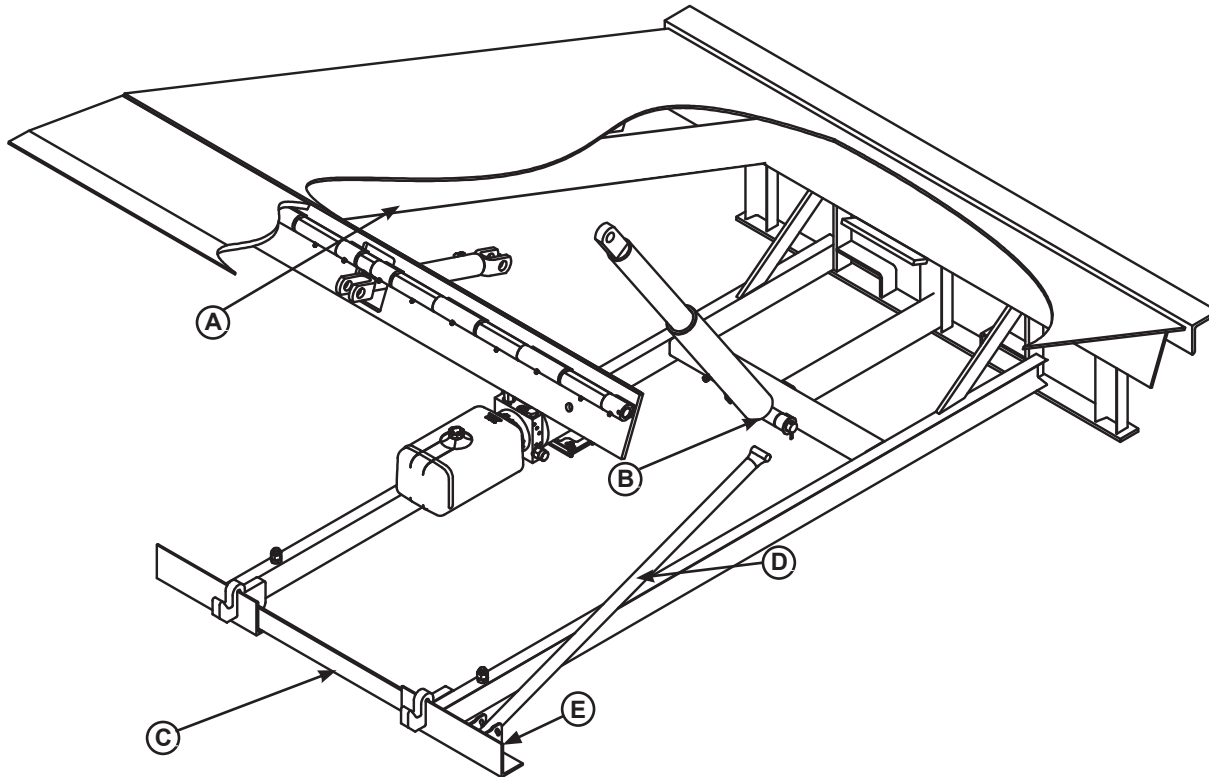

Figure 12

A — Platform Joists

B — Shim Location (Under Platform Cylinder Trunnions)

C — Removable “Clean Sweep” Frame Section

D — Maintenance Prop

E — Shim Location (Under Maintenance Prop)

17. Shim and weld the maintenance prop:

- a. Install shims under maintenance prop (**D**) where prop attaches to leveler frame. Make sure prop is solidly shimmed.
- b. Raise maintenance prop (**D**) to the service (upright) position and lock prop in this position using an OSHA approved locking device.

18. Install shims at locations (**B and E**) using an appropriate shimming method (see Figure 14). Both platform cylinder trunnions must be solidly shimmed the entire length of the trunnion. Make sure the trunnions are level from side-to-side as well as from front-to-back.

19. Finish weld all shims using a fillet weld.

- Weld all shims within each shim stack to each other, then weld the shim stack to the leveler frame.
- Weld the front leveler frame shim stacks to the front pit curb steel.

## **WARNING**

DO NOT use the maintenance prop to support the raised platform until the maintenance prop has been properly shimmed and welded. The shims must be welded to each other, and also to the leveler frame.

## **WARNING**

Make sure the platform is properly supported in the raised position before entering the pit to finish weld the shims.

## Install Dock Leveler (continued)

20. Remove the Shipping Bar (C) by grinding the tack welds that hold it in place during transport.

### NOTICE

LH models are shipped with a front frame section (C) installed. This temporary frame holds the leveler frame at the correct dimensions until the leveler is permanently anchored into place. Only then should it be removed.

There are four cap screws and nuts that fasten the T-frame to the rest of the leveler frame. Tack welds may also be used.

21. When all welding has been completed, paint all the welds and shims.
22. Install the dock bumpers as required.
23. Remove red shipping plug from hydraulic fluid reservoir and install black breather cap. Discard red shipping plug. See Figure 13.

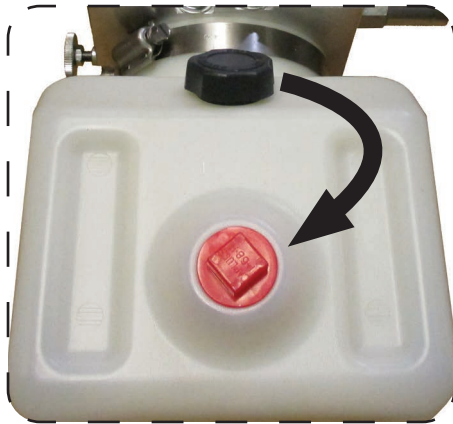

Figure 13

24. Proceed to “Install Control Panel and Wiring” on Page 20.

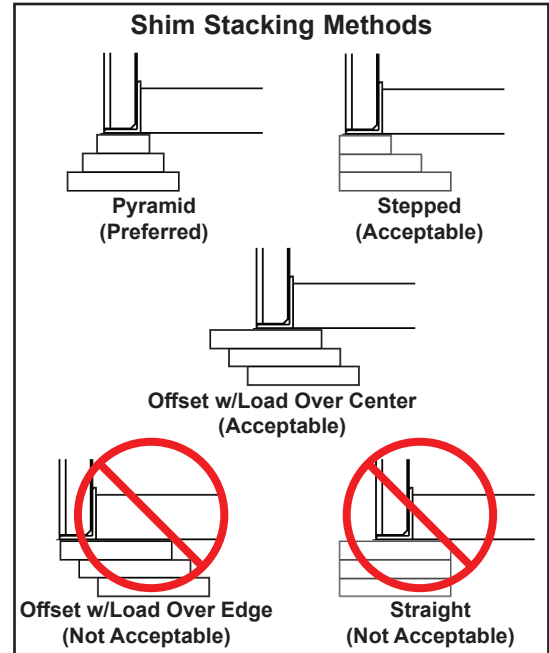

Figure 14

# INSTALLATION

## Install Control Panel and Wiring

### **! DANGER**

Make sure that the power source has been locked out and tagged according to OSHA regulations and approved local electrical codes.

### **! WARNING**

A hard hat or other applicable head protection should always be worn when working under or around a dock leveler.

Always stand clear of platform lip when working in front of the dock leveler.

### **! CAUTION**

All electrical work — including the installation of the disconnect panel, control panel, and final connections to the pit junction box — must be performed by a certified electrician and conform to all local and applicable national codes.

### **NOTICE**

DO NOT connect any dock equipment electrical wiring or ground connections until all welding has been completed.

DO NOT ground welding equipment to any electrical components of the dock equipment. Always ground welding equipment to the dock leveler frame, NEVER to the platform.

Failure to follow these instructions may damage the motor, wiring, and/or control panel.

### **NOTICE**

Where indicated, all components must be connected to a SAFETY EARTH GROUND that conforms to the 1999 National Electrical Code Section 250-50 section (a) or section (c) for a grounding electrode system.

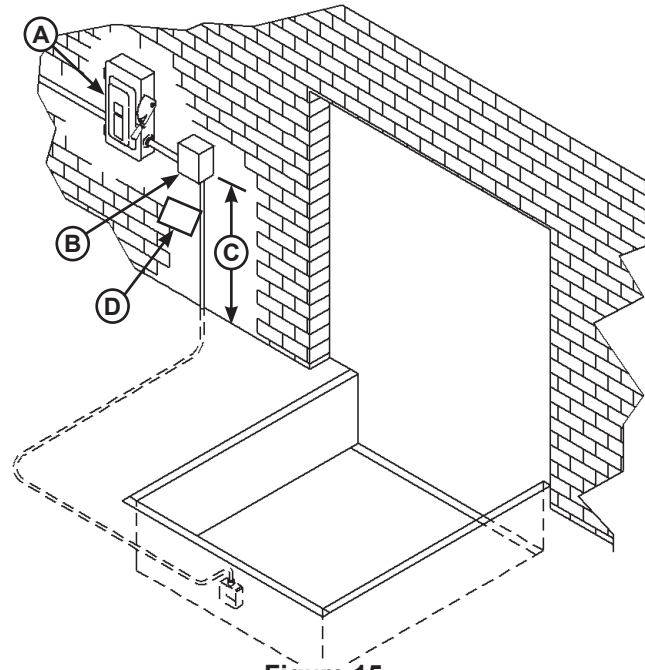

**Figure 15**

**A**— Disconnect Panel (provided by others)      **C**— Distance, 48 in. (1219 mm)  
**B**— Control Panel      **D**— Placard

1. Mount the control panel (**B**) so bottom of control panel-to-dock floor distance is 48 in. (1219 mm, **C**).
2. Install electrical disconnect panel (**A**) if not already installed (provided by others). It is recommended to locate disconnect panel adjacent to control panel (**B**).
3. Install and connect the control wiring as shown in installation drawings.
4. Connect the control wiring to the field wires in the dock equipment junction boxes. Refer to the electrical diagrams supplied with the dock equipment.

**Note:** When installing electrical controls in a temperature-controlled environment, the installer must determine an appropriate means to isolate/prevent thermal and vapor transfer through electrical conduit where conduit routing crosses temperature zones. Systems, LLC is not responsible for any damage due to moisture collecting inside the control panel caused by improper isolation/prevention of thermal and vapor transfer through the conduit. Refer to Tech Service Bulletin 19-053 for more information.

5. Install placard (**D**). Make sure placard is in plain view of dock leveler and/or vehicle restraint operations. Suggested placement of placard is near control box attached to electrical conduit by using nylon cable tie. See page 22.

## Danfoss Control Panel Wiring (1-Phase)

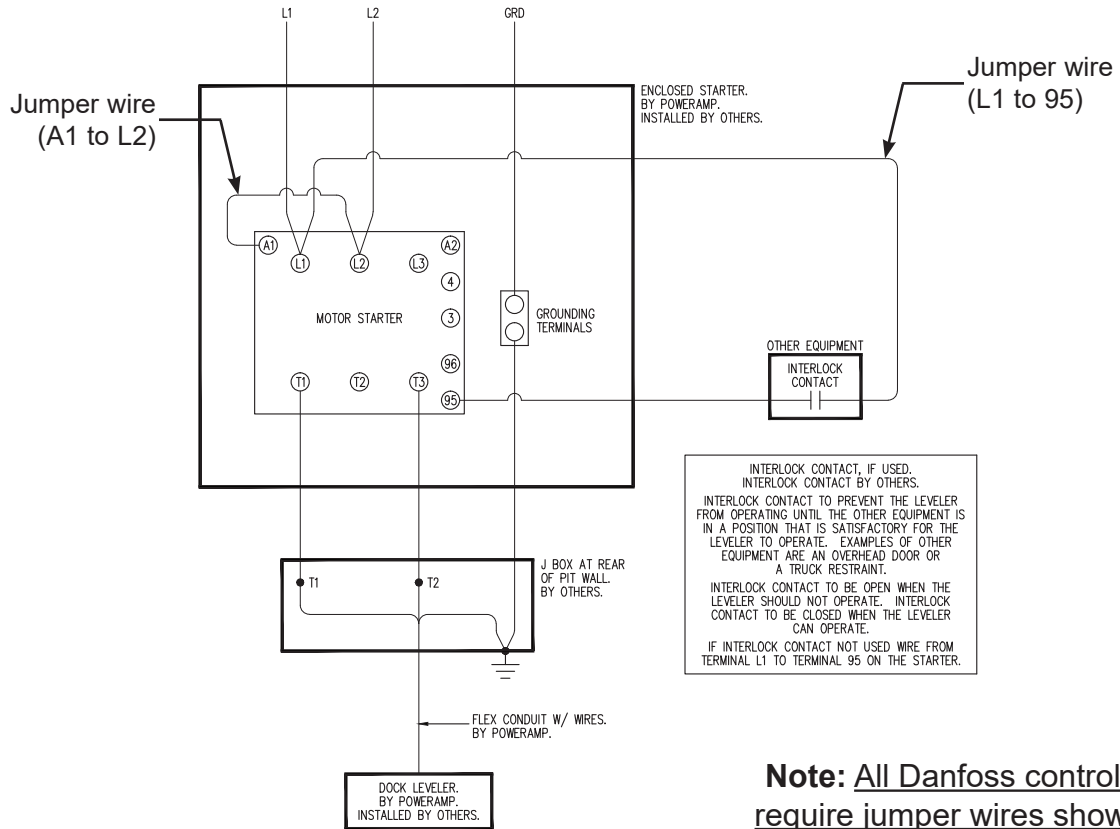

## Danfoss Control Panel Wiring (3-Phase)

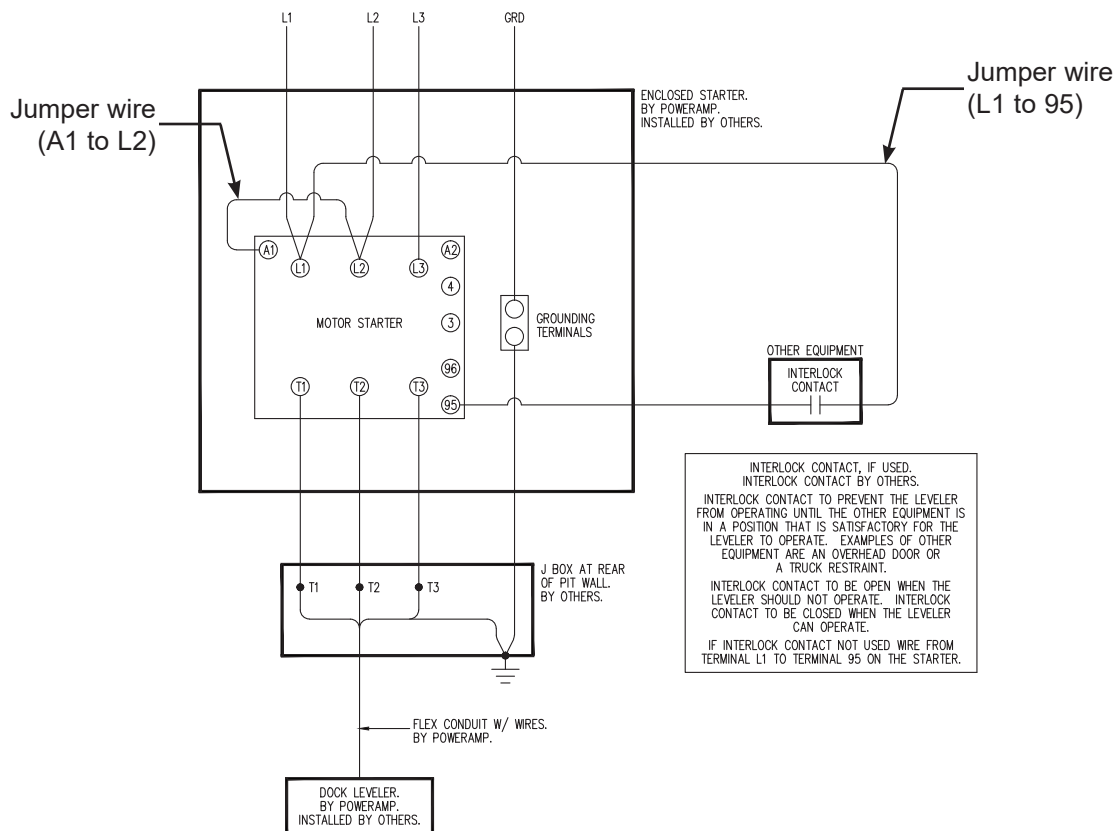

# INSTALLATION

## Placard Installation Instructions

- Owner/Users are responsible for the installation and placement of product placards.
- Make sure placard is in plain view of dock leveler and/or vehicle restraint operations.
- Suggested placement of placard is near control box attached to electrical conduit by using nylon cable tie. If there is no control box present, mount placard on wall to the immediate left of leveler at eye level.

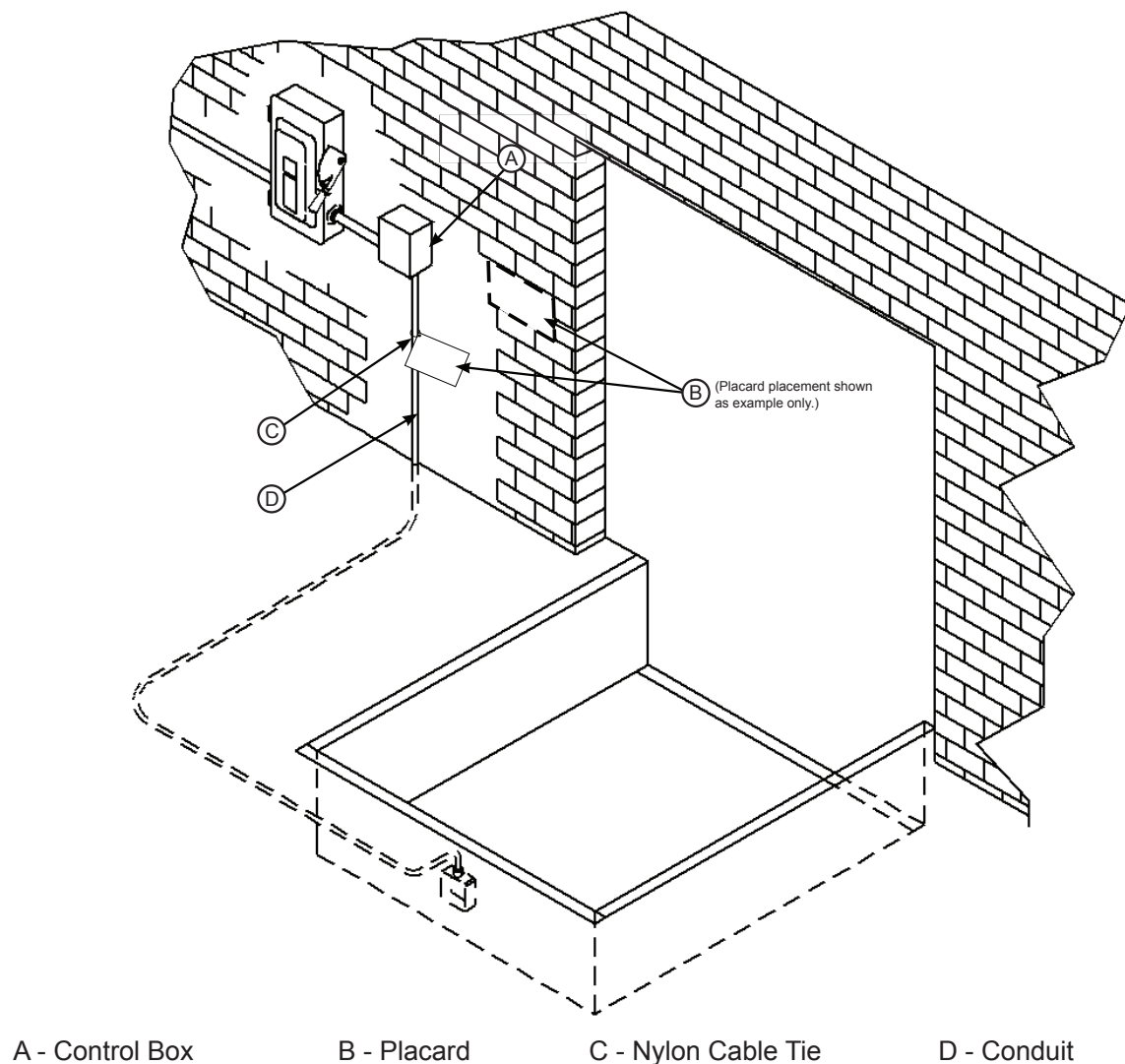

Figure 16



This page intentionally left blank.

# INSTALLATION

## Put New Dock Leveler Into Service

### **WARNING**

A hard hat or other applicable head protection should always be worn when working under or around a dock leveler.

Always stand clear of platform lip when working in front of the dock leveler.

1. Disconnect the external lifting device and chains from the lifting brackets.

2. Check that the leveler is flush with the dock floor and that the platform lip contacts both lip keepers evenly.

**Note:** If an excessive transition exists between the dock floor and leveler and/or lip does not contact both lip keepers evenly, contact Systems, LLC Technical Services for further instructions.

3. Turn the main electrical power ON.

4. Raise the leveler platform fully by Pressing and holding the RAISE button.

**Note:** The platform of a properly operating dock leveler will automatically stop rising when it reaches its maximum full raised height, at which point, the lip extends. When the lip is fully extended, the powerpack will go into pressure relief. (If the lip does not extend correctly, see Troubleshooting section.)

5. Release the RAISE button to lower the platform. As long as there is no vehicle present at the dock, the platform will lower to the full below-dock position as the lip folds.

**Note:** If a transport vehicle is present, the platform will lower until the lip rests on the transport vehicle's bed.

6. When the platform lowers to the full below-dock position, Press and hold the RAISE button until the platform rises just enough to clear the lip keepers, then release the RAISE button to allow the platform to lower to the cross-traffic (stored) position (lip engages lip keepers).

**Note:** For dock levelers equipped with the Auto Return To Dock (ARTD), the platform will automatically return to the cross-traffic position if the ARTD is enabled. When the platform is at the full below-dock position, there is a six-second delay before the platform will automatically rise to the cross-traffic position.

7. Perform steps 4-6 at least four times to purge any air that may be in the hydraulic system and to ensure proper operation.

8. Raise the platform fully. Hold the platform at this position using the RAISE button and move the maintenance prop to the service (upright) position. Release the RAISE button to allow the platform to lower until it is resting on the maintenance prop.

### **DANGER**

Unless the dock leveler is equipped with a tethered remote, two people are required to engage the maintenance prop: one person to operate the unit, the other person to engage the maintenance prop.

In addition, it is recommended and good safety practice to use an additional means to support the dock platform and lip anytime when physically working in front of or under the dock leveler. This additional means may include, but is not limited to a boom truck, fork truck, stabilizing bar or equivalent.

9. Secure the maintenance prop with the maintenance prop lock-out.

10. With the maintenance prop supporting the platform, remove the lifting brackets.

11. Release the maintenance prop by unlocking the lock-out.

12. Press and hold the RAISE button until the maintenance prop drops to its stored position. Release the RAISE button and allow the platform to lower fully.

## Operational Precautions

### **DANGER**

Stay clear of dock leveler and vehicle restraint when transport vehicle is entering or leaving dock area.

DO NOT move or use the dock leveler or restraint if anyone is under or in front of leveler.

Keep hands and feet clear of pinch points. Avoid putting any part of your body near moving parts.

### **WARNING**

Only trained personnel should operate the dock leveler.

DO NOT use a broken or damaged dock leveler. Make sure proper service and maintenance procedures have been performed on leveler before using.

Transport vehicle wheels must be chocked unless a vehicle restraint is used. Never remove the wheel chocks until loading/unloading is finished and transport driver has been given permission to leave.

Make sure platform lip rests on the transport vehicles bed with at least 4 in. (102 mm) of overlap.

Maintain a safe distance from side edges of leveler during the loading/unloading process.

### **WARNING**

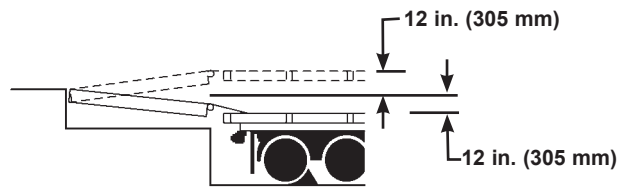

The LHD hydraulic dock leveler is designed to compensate for a maximum  $\pm 12$  in.\* (305 mm) of height difference between the loading dock and the transport vehicle bed. DO NOT use the dock leveler if the transport vehicle bed is more than 12 in. (305 mm) higher or lower than the dock floor.

\*Service height may vary with design specifications

DO NOT overload the dock leveler.

DO NOT operate any equipment while under the influence of alcohol or drugs.

DO NOT leave equipment or material unattended on the dock leveler.

# OPERATION

---

## Operating Instructions

### Ramp Loading/Unloading

1. Before activating dock leveler, check to make sure the transport vehicle is positioned squarely against dock bumpers. Ensure lip will avoid contact with transport vehicle frame, sides and cargo during dock leveler activation. If contact is likely or observed, reposition transport vehicle.

2. Instruct driver to remain at the dock until the loading or unloading process has been completed.

3. Chock the transport vehicle wheels, or use a vehicle restraint if available.

4. Extend the dock leveler onto the transport vehicle as follows:

- a. Raise the platform by pressing and holding the RAISE button.
- b. Hold the RAISE button until the lip is fully extended, then release the RAISE button. The platform will lower until the lip is resting on the transport vehicle bed.
- c. Make sure that the lip is fully extended and supported on the transport vehicle along the entire width of the platform, with at least 4 in. (102 mm) of lip contacting the transport vehicle bed. See Figure 17.

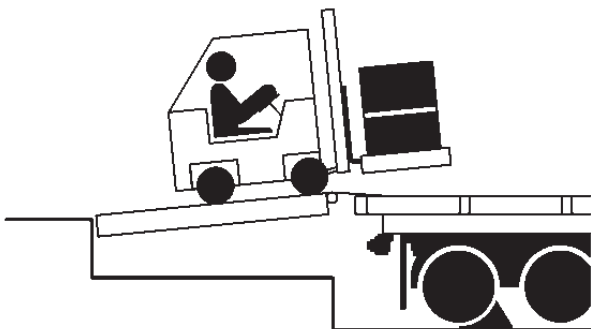

**Figure 17**

5. Proceed with loading or unloading the transport vehicle.

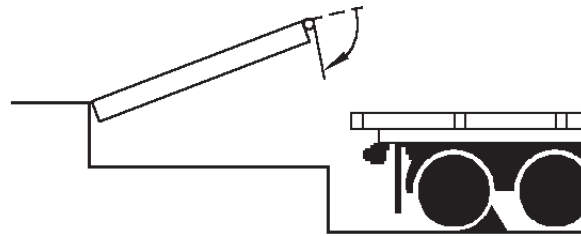

**Figure 18**

6. When loading or unloading is finished, raise the platform by pressing and holding the RAISE button until the lip folds enough to land in the lip keepers, then release the RAISE button. The platform will return to the cross-traffic position. See Figure 18.

7. Remove chocks from transport vehicle wheels, or release the vehicle restraint if used.

8. Indicate to driver that the transport vehicle may leave the dock.

## Operating Instructions (continued)

### End Loading/Unloading

1. Before activating dock leveler, check to make sure the transport vehicle is positioned squarely against dock bumpers. Ensure lip will avoid contact with transport vehicle frame, sides and cargo during dock leveler activation. If contact is likely or observed, reposition transport vehicle.

2. Instruct driver to remain at the dock until the loading or unloading process has been completed.

3. Chock the transport vehicle wheels, or use a vehicle restraint if available.

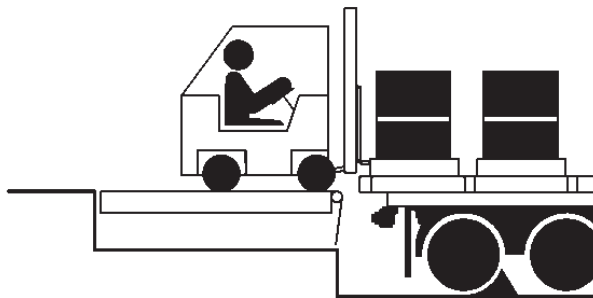

**Figure 19**

4. If transport vehicle bed is at or above dock floor level, leave leveler at the cross-traffic position and proceed with loading or unloading (see Figure 19). If transport vehicle bed is below the dock floor level, continue with Step 5.

5. Raise the platform by pressing and holding the RAISE button until the lip extends just enough to clear the lip keepers, then release the RAISE button.

6. Allow the platform to drift down to the full below-dock position.



**Figure 20**

7. Proceed with loading or unloading (see Figure 20).

**Note:** When end unloading is finished and access to the rest of the transport vehicles is still required, the platform lip will need to be extended. See Ramp Loading/Unloading Instructions on page 24 for further instructions.

8. When end loading or unloading is finished, raise the platform by pressing and holding the RAISE button until the lip folds enough to land in the lip keepers, then release the RAISE button. The platform will return to the cross-traffic position.

9. Remove chocks from transport vehicle wheels, or release the vehicle restraint if used.

10. Indicate to driver that the transport vehicle may leave the dock.

# MAINTENANCE

## Maintenance Precautions

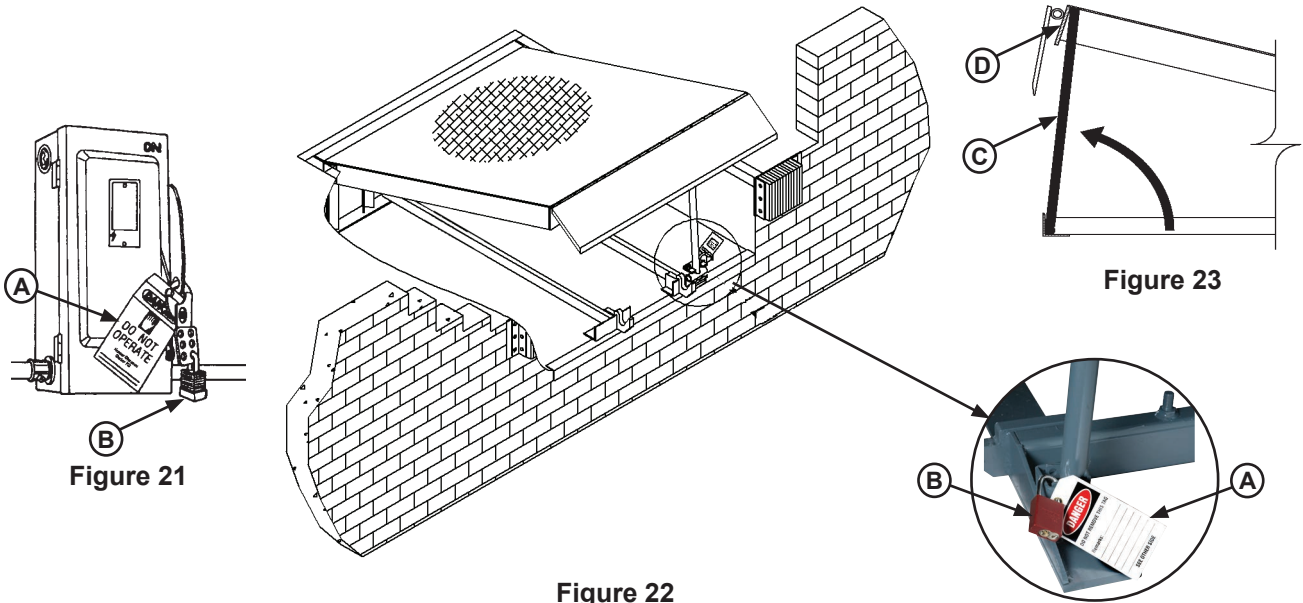

Figure 21

Figure 23

Figure 22

A— Tag Out Device    B—Lock Out Device    C — Maintenance Prop    D— Header

**! DANGER**

Unless the dock leveler is equipped with a tethered remote, two people are required to engage the maintenance prop: one person to operate the unit, the other person to engage the maintenance prop.

In addition, it is recommended and good safety practice to use an additional means to support the dock platform and lip anytime when physically working in front of or under the dock leveler. This additional means may include, but is not limited to a boom truck, fork truck, stabilizing bar or equivalent.

When working with electrical or electronic controls, make sure that the power source has been tagged (A) and locked out (B) according to OSHA regulations and approved local electrical codes (see Figure 21).

Whenever maintenance is to be performed under the dock leveler platform, support the platform with maintenance prop (C). Position the maintenance prop behind front header plate (D) while staying clear of the lip. The lip will fold down after the platform has rested on the maintenance prop. Lock the maintenance prop in the service (upright) position using an OSHA approved lockout device\* (B) and tag out device\* (A). See Figures 22 and 23.

**! WARNING**

Always post safety warnings and barricade the work area at dock level and ground level to prevent unauthorized use of the unit before maintenance is complete.

Only the person servicing the equipment should have the capability to remove the lockout devices. The tag out devices\* must inform that repairs are in process and clearly state who is responsible for the lockout condition.

**! WARNING**

A hard hat or other applicable head protection should always be worn when working under or around a dock leveler.

Always stand clear of platform lip when working in front of the dock leveler.

\* Refer to OSHA regulations 1910.146. Confined Space and 1910.147. Lockout/Tagout

This page intentionally left blank.

# MAINTENANCE

## Periodic Maintenance

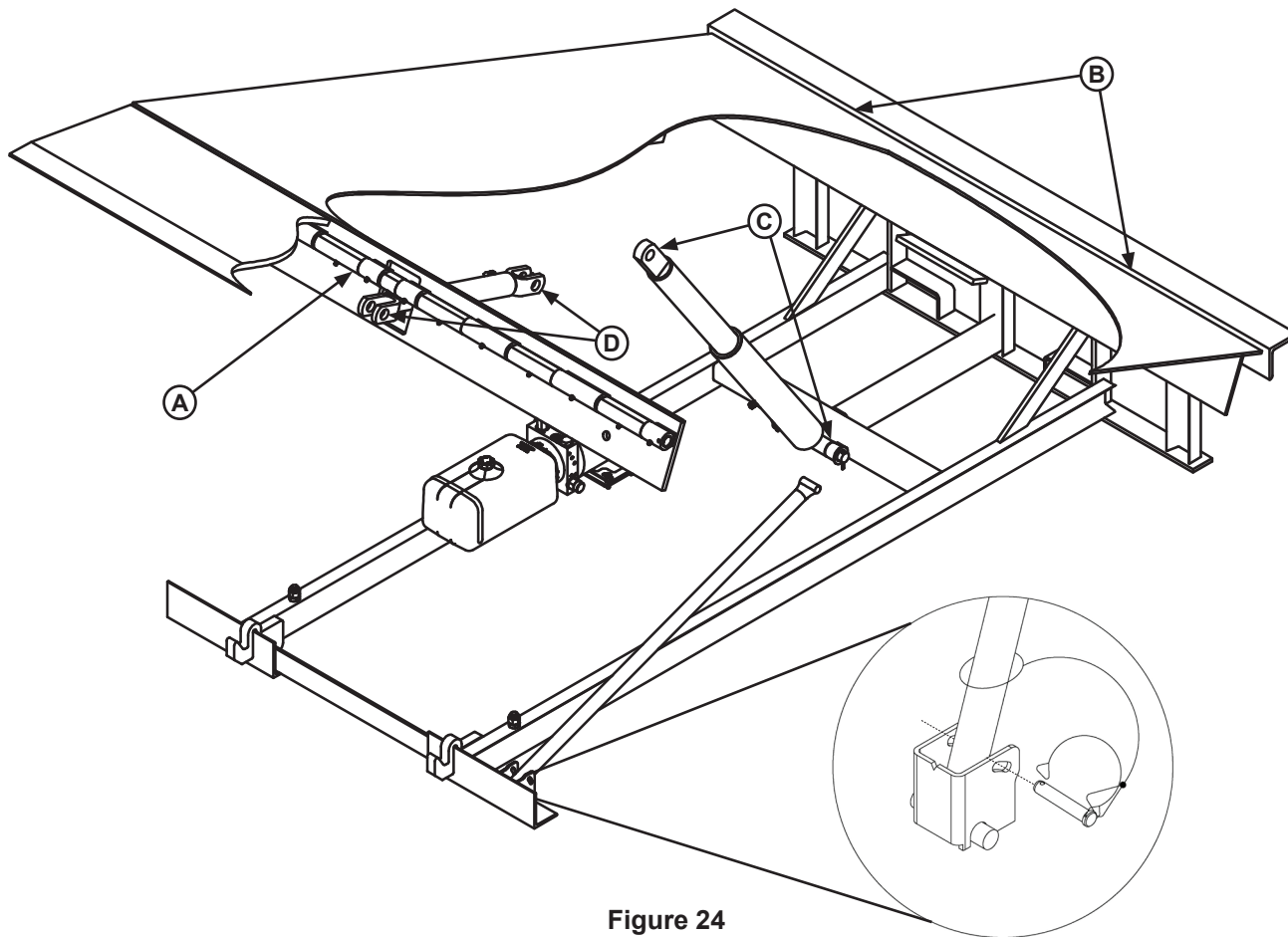

Figure 24

A— Lip Area  
B— Platform Hinge Area

C— Main Cylinder Pins  
D— Lip Cylinder Pins

To ensure normal operation of the dock leveler, use only aircraft hydraulic fluid designed to meet or exceed military specification MIL-H-5606-G. It is recommended that the following hydraulic fluids be used:

- ULTRA-VIS-HVI-15
- Aero Shell Fluid 4 or Fluid 41
- Mobil Aero HFA Mil-H5606A or Aero HF
- Texaco Aircraft Hydraulic Oil 15 or 5606
- Exxon Univis J13
- Castrol Brayco Micronic 756

These fluid brands can be mixed together. Use of hydraulic fluids with equivalent specifications to those listed here are acceptable.

## NOTICE

Use of fluids that do not have equivalent specifications to those in the preceding list will result in abnormal operation of the dock leveler and voiding of warranty.

### Weekly Maintenance

- Operate the dock leveler through the complete operating cycle to maintain lubrication.

**Note:** To thoroughly inspect the platform hinge area, put the platform in the full below-dock position.

- Inspect the platform hinge and the lip hinge areas. The hinge areas must be kept free of dirt and debris. Build-up of foreign material in the hinge areas will cause abnormal operation.
- Inspect warning decals and placards. Replace if damaged or missing.



## Quarterly Maintenance

- Complete Weekly Maintenance.
- Inspect the following for damage/abnormal wear:
  - Check welds for cracks.
  - Cylinder pins and mounting holes.
  - Lip hinge pins and rear hinge pins.
  - Check full range toe guards (if equipped) for free movement.
  - Check J-box for water damage.
  - Inspect hoses, cylinders, fittings and powerpack.
  - Control box and conduit for damage.
  - Bumpers for more than 1" of wear. Replace worn, loose, damaged or missing bumpers.
  - Side and rear weather seals (if equipped).
- Lubricate the following areas with light weight machine oil (see Figure 24):
  - (A) — Lip hinge area unless equipped with grease fittings (apply oil to the top of the entire length of lip hinge when platform is at the full below-dock position and lip is folded)
  - (B) — Platform rear hinge area (apply oil to top of all platform hinges when platform is at the full below-dock position)
- Lubricate the following areas with white lithium grease:
  - (C) — Platform cylinder pins
  - (D) — Lip cylinder pins

**Note:** Apply grease to lip hinge grease fittings if equipped.

## **NOTICE**

Failure to properly lubricate the dock leveler will cause abnormal operation of the leveler.

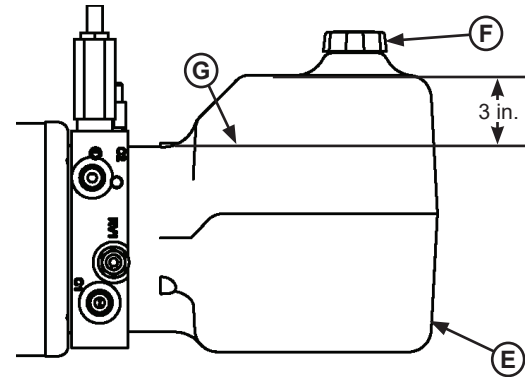

**Figure 25**

E - Reservoir

G - Fluid Level

F - Breather Cap

- Check reservoir fluid level (G, see Figure 25):
  1. Put the dock leveler platform at the full below-dock position.
  2. Turn OFF all electrical power to the leveler.
  3. Remove breather cap (F).
  4. Measure fluid level. The fluid level should be approximately 3 in. (76.5 mm) from top of reservoir (E) with platform at the below-dock position.
  5. Add hydraulic fluid if necessary. Use only recommended fluid (see page 30).
  6. Install breather cap.
  7. Turn ON electrical power to the leveler.
  8. Return the platform to the cross-traffic position.

## Yearly Maintenance

- Complete Quarterly Maintenance.
- Change hydraulic oil (may be required more often depending upon conditions).

# ADJUSTMENTS

## Adjust Main Pressure Relief

### **DANGER**

Unless the dock leveler is equipped with a tethered remote, two people are required to engage the maintenance prop: one person to operate the unit, the other person to engage the maintenance prop.

In addition, it is recommended and good safety practice to use an additional means to support the dock platform and lip anytime when physically working in front of or under the dock leveler. This additional means may include, but is not limited to a boom truck, fork truck, stabilizing bar or equivalent.

### **WARNING**

When service under the dock leveler is required, always lock all electrical disconnects in the OFF position after raising the platform and engaging the maintenance prop.

Always post safety warnings and barricade the work area at dock level and ground level to prevent unauthorized use of the dock leveler before maintenance is complete.

A hard hat or other applicable head protection should always be worn when working under or around a dock leveler.

Always stand clear of platform lip when working in front of the dock leveler.

### Main Pressure Relief Adjustment

**Typically set to 2.5 turns out from dead in;** adjusting RV1 clockwise increases system pressure, and adjusting RV1 counter-clockwise decreases system pressure.

The main pressure relief valve (RV1) may need to be *increased* if the platform does not rise or rises slowly and the system operates in pressure relief mode.

The main pressure relief valve (RV1) may need to be *decreased* if the pump motor loads down when platform reaches the full raised position.

See Troubleshooting section on pages 34-37 for more information.

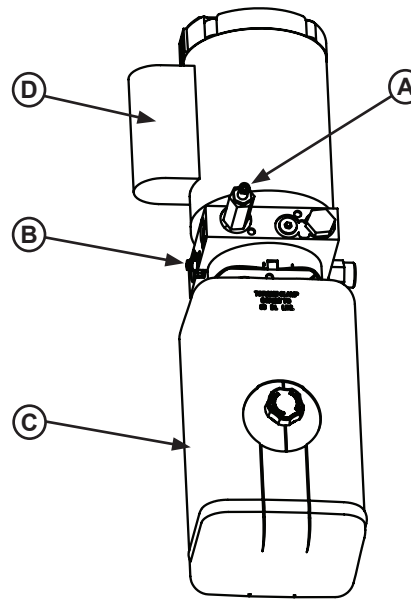

**Figure 26**

A — Sequence Valve      C — Fluid Reservoir  
B — Pressure Relief Valve (RV1)      D — Motor

1. Raise the platform fully and engage the maintenance prop in the service position.
2. Turn OFF all electrical power to the dock leveler.
3. Attach lock out/tag out devices.
4. Loosen jam nut on pressure relief valve (B).
5. Adjust hex adjusting screw as follows:
  - To increase pressure relief, turn hex screw clockwise in 1/4 turn increments.
  - To decrease pressure relief, turn hex screw counterclockwise in 1/4 turn increments.
6. Tighten the jam nut on pressure relief valve (B).
7. Turn ON electrical power to the dock leveler.
8. Remove lock out/tag out devices.
9. Disengage the maintenance prop.
10. Cycle leveler and verify pressure relief setting.
11. Repeat steps 1– 10 as necessary.

## Adjust Lip Function

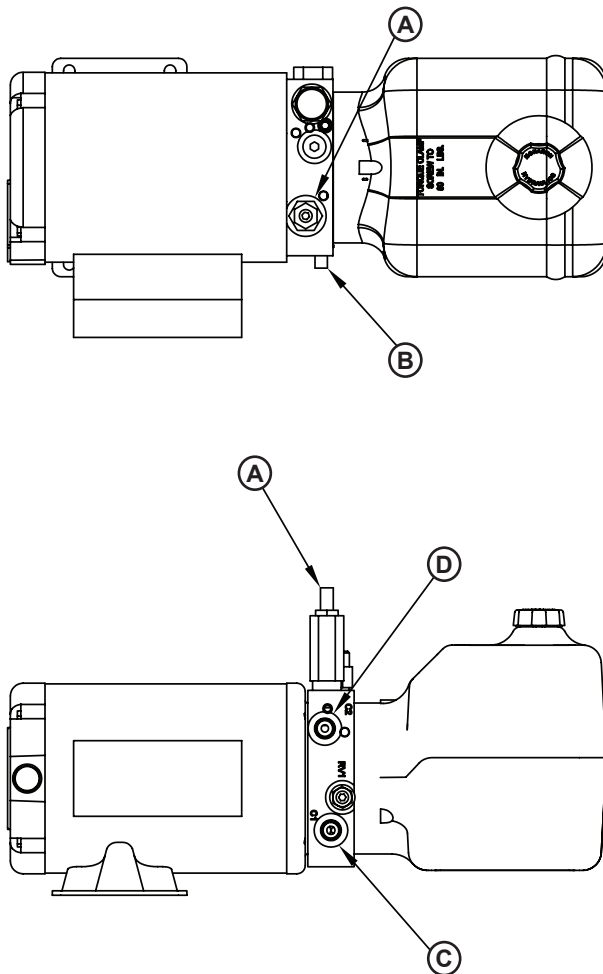

Figure 27

A — Sequence Valve      C — C1 Port (Hoist Cyl.)  
 B — Pressure Relief Valve      D — C2 Port (Lip Cyl.)

## NOTICE

All LH-series dock levelers are factory tested, and should not require additional adjustments in the field. Consult Systems, LLC Technical Services if minor adjustments do not result in proper operation.

Whenever valve adjustments are completed, record the number of turns made to allow an undesirable adjustment result to be reversed.

## Sequence Valve Adjustment

Typically set to 7 turns out from dead in (750 PSI); adjusting clockwise increases pressure required to shift valve, and adjusting counter-clockwise decreases pressure required to shift valve.

See Troubleshooting section on pages 34-37 for more information.

1. Raise the platform fully and engage the maintenance prop in the service position.
2. Turn OFF all electrical power to the dock leveler.
3. Attach lock out/tag out devices.
4. Loosen jam nut.
5. Adjust hex adjusting screw (B) as follows:
  - If the lip opens as the platform begins to rise, turn sequence valve clockwise in 1/4 turn adjustments until operation is satisfactory.
  - If the lip will not fully retract when the platform returns to the stored position, turn sequence valve counterclockwise in 1/4 turn increments.
6. Tighten the jam nut.
7. Turn ON electrical power to the dock leveler.
8. Remove lock out/tag out devices.
9. Disengage the maintenance prop.
10. Cycle leveler and verify lip operation.
11. Repeat steps 1– 10 as necessary.

# TROUBLESHOOTING

## **DANGER**

Unless the dock leveler is equipped with a tethered remote, two people are required to engage the maintenance prop: one person to operate the unit, the other person to engage the maintenance prop.

In addition, it is recommended and good safety practice to use an additional means to support the dock platform and lip anytime when physically working in front of or under the dock leveler. This additional means may include, but is not limited to a boom truck, fork truck, stabilizing bar or equivalent.

## **WARNING**

When service under the dock leveler is required, always lock all electrical disconnects in the OFF position after raising the platform and engaging the maintenance prop.

Always post safety warnings and barricade the work area at dock level and ground level to prevent unauthorized use of the dock leveler before maintenance is complete.

A hard hat or other applicable head protection should always be worn when working under or around a dock leveler.

Always stand clear of platform lip when working in front of the dock leveler.

**Before performing the detailed troubleshooting procedures, check the following items first:**

- Check fuse(s) and circuit breaker(s). Replace any blown fuse(s) with a fuse of equal specification.
- Make sure the correct voltages are present at the proper locations inside the control panel(s).

Symptom	Possible Cause	Solution
<b>Platform does not rise. Motor does not energize.</b>	Motor overload device tripped.	Reset overload relay or breaker. Determine cause of device tripping.
	Motor starter (three-phase) or motor relay (single-phase) not energizing.	Check voltage at starter or relay coil. <ul style="list-style-type: none"> <li>• If voltage is present and starter or relay does not energize, replace starter or relay.</li> <li>• If voltage is not present, check all components in series with the starter or relay coil.</li> </ul>
<b>Three-phase units only: Platform does not rise. Motor runs in reverse</b>	Phase reversed.	Reverse any two legs at the branch circuit disconnect.

# TROUBLESHOOTING

Symptom	Possible Cause	Solution
<b>Three-phase units only:</b> <b>Platform does not rise.</b> <b>Motor hums, but does not run.</b>	No voltage is present on one line.  <i>NOTE: A motor that is missing voltage on one line is said to be single-phased.</i>	Check for blown fuses at branch circuit disconnect. Replace fuse. Determine cause of blown fuse.
		Check motor starter as follows: 1. Disconnect wires at load side of starter. 2. Energize the starter. 3. Measure line-to-line voltage at line side of starter. 4. Measure line-to-line voltage at load side of starter. 5. Line-side and load-side voltages should be approximately the same. Replace starter if voltage values are considerably different from one another.
		Check all wiring to motor for high resistance or no connection.
<b>Single-phase units only:</b> <b>Platform does not rise.</b> <b>Motor energizes, but does not run.</b>	Line voltage too low.	Check wiring to motor for high resistance. Check for loose or corroded connections. Check if gauge of wires to motor are of correct size and specification for load requirement. Replace if necessary.
	Faulty motor centrifugal switch.	Replace motor.
	Faulty motor capacitor.	Replace motor.
<b>Platform does not rise. Pump operates in pressure relief mode.</b>	Heavy object(s) on platform.	Remove object(s) from platform.  <b>Note:</b> For safety reasons, the dock leveler is designed to lift only the platform's own weight.
	Dock leveler binds.	Check for visible obstructions that could cause binding. Remove obstructions. If no obstructions found, contact Systems, LLC Technical Services.
	Pressure relief set too low.	Increase pressure relief. See page 32 for instruction.  <b>Note:</b> The pressure relief valve must not be set at a level that causes the motor operating current to exceed the full load amp value* at any time, including when operating in pressure relief.  <i>* The full load amp value can be found on the inside cover of the control panel.</i>

# TROUBLESHOOTING

Symptom	Possible Cause	Solution
<b>Platform rises slowly.</b>	Low hydraulic fluid.	Add fluid, see pages 30-31 for proper fluid level and type.
	Contaminated hydraulic system.	Clean and inspect valves. Flush contaminated oil from hydraulic system. Fill system with new oil. See pages 30-31.
	Damage or blocked hydraulic hose(s) and/or valve(s).	Replace damaged hose(s). Check and remove blockage from hose(s) and/or valve(s).
	Pressure relief set too low.	<p>Increase pressure relief. See page 32 for instruction.</p> <p><b>Note:</b> The pressure relief valve must not be set at a level that causes the motor operating current to exceed the full load amp value* at any time, including when operating in pressure relief.</p> <p><i>* The full load amp value can be found on the inside cover of the control panel.</i></p>
<b>Pump motor loads down when platform reaches the full raised position.</b>	Pressure relief set too high.	<p>Decrease pressure relief. See page 32 for instruction.</p> <p><b>Note:</b> The pressure relief valve must not be set at a level that causes the motor operating current to exceed the full load amp value* at any time, including when operating in pressure relief.</p> <p><i>* The full load amp value can be found on the inside cover of the control panel.</i></p>
<b>Platform does not rise to full height.</b>	Low hydraulic fluid.	Add fluid, see pages 30-31 for proper fluid level and type.

# TROUBLESHOOTING

Symptom	Possible Cause	Solution
<b>Lip does not stay extended when leveler lowers.</b>	Faulty lip cylinder.	Replace lip cylinder.
<b>Platform DOES rise to full height, but lip DOES NOT extend or extend fully.</b>	Sequence Valve requires adjustment.	Adjust valve as necessary. See page 33 for adjustment instructions.
<b>Lip does not extend.</b>	Sequence Valve requires adjustment.	Adjust valve as necessary. See page 33 for adjustment instructions.
<b>Lip extends almost immediately when the RAISE button is Pressed.</b>	Sequence Valve requires adjustment.	Adjust valve as necessary. See page 33 for adjustment instructions.
<b>Platform locks into “safety” as platform lowers. Lip drops to vertical position.</b>	Faulty velocity fuse.	Replace velocity fuse.
	Incorrect or aged hydraulic fluid.	Replace hydraulic fluid, see pages 30-31 for proper fluid level and type.

If additional troubleshooting assistance is required, contact Systems, LLC Technical Services with equipment serial number or customer order number (CO#).

**Technical Service at 800-643-5424 or [techservices@loadingdocksystems.com](mailto:techservices@loadingdocksystems.com)**

# PARTS

## Danfoss Control Box



Part Number	Voltage	Phase	Description
7141-0268	110v	1-Phase	Danfoss Control Box (MTR 3627A)
7141-0269	230v	1-Phase	Danfoss Control Box (MTR 3627C)
7141-0270	230v	3-Phase	Danfoss Control Box (MTR 3627E)
7141-0271	460v	3-Phase	Danfoss Control Box (MTR 3627F)

\* Provide dock leveler serial number, voltage, phase, and options when e-mailing, calling or faxing controller orders.



## Optional Electrical Parts (Control Box)

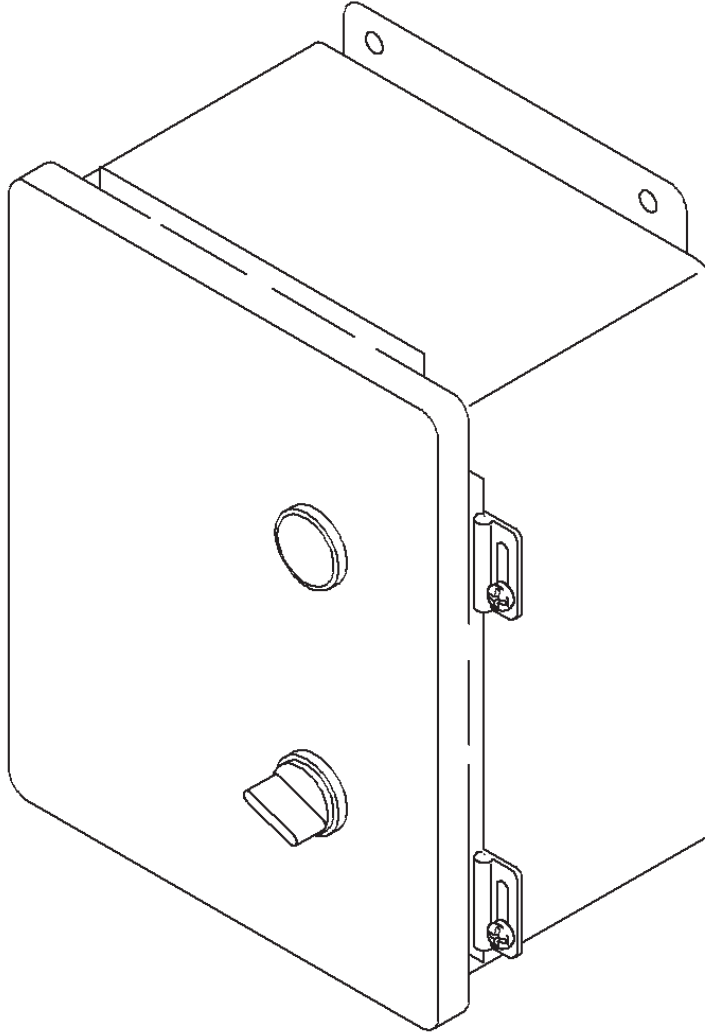

Part Number	Description
*	Control Box w/Optional Equipment

\* Provide dock leveler serial number, voltage, phase, and options when e-mailing, calling or faxing controller orders.

# PARTS

## Frame and Platform

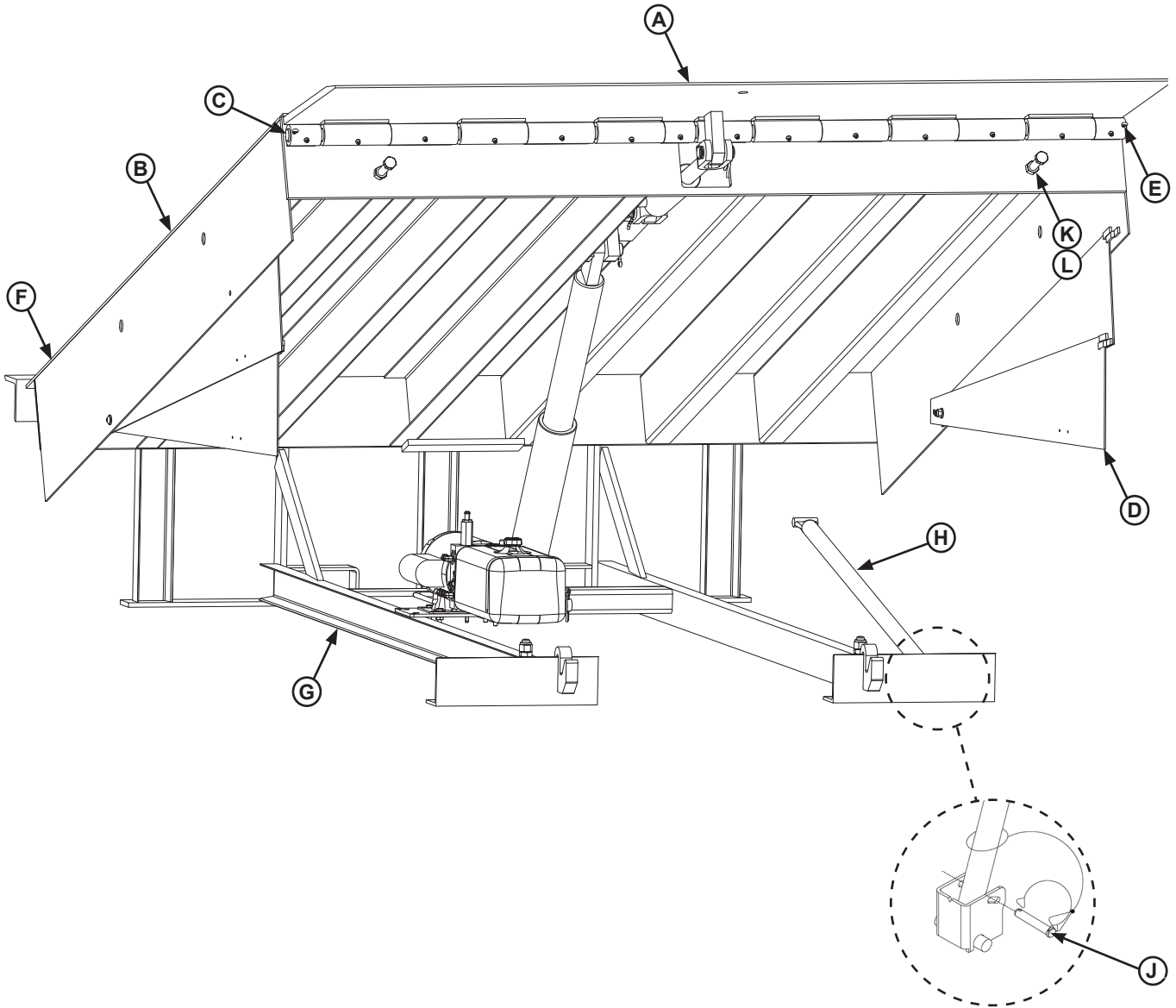

---

**Frame and Platform**

Item	Quantity	Part Number	Description
A	1	DLIP-____ <sup>1</sup>	Lip, Welded Assembly
B	1	DPLA-____ <sup>1</sup>	Platform, Welded Assembly
C	2	DPLA-2101	Pin, Lip Hinge, 1" OD x 35.25
		DPLA-2102	Pin, Lip Hinge, 1" OD x 38.25
		DPLA-2103	Pin, Lip Hinge, 1" OD x 40.5
D	1	See Page 46	Toe Guard Assembly
E	2	DOTH-2382	Cotter Pin, 1/4 x 2
F	3	9202-0002	Rear Hinge Pin
		9202-0009	Rear Hinge Pin, Stainless Steel <b>(Optional)</b>
G	1	8435-____ <sup>1</sup>	Frame, LH
H	1	9225-____ <sup>1</sup>	Maintenance Prop Rod
J	1	9201-0006	Prop Pin & Clip
K	2	DOTH-2160	Nut, Hex, 5/8-11
L	2	2101-0243	Screw, HHCS, 5/8-11 UNC x 2.5

<sup>1</sup> Provide dock leveler serial number, platform size, and lip size when calling or faxing orders.

# PARTS

## Hydraulic Components

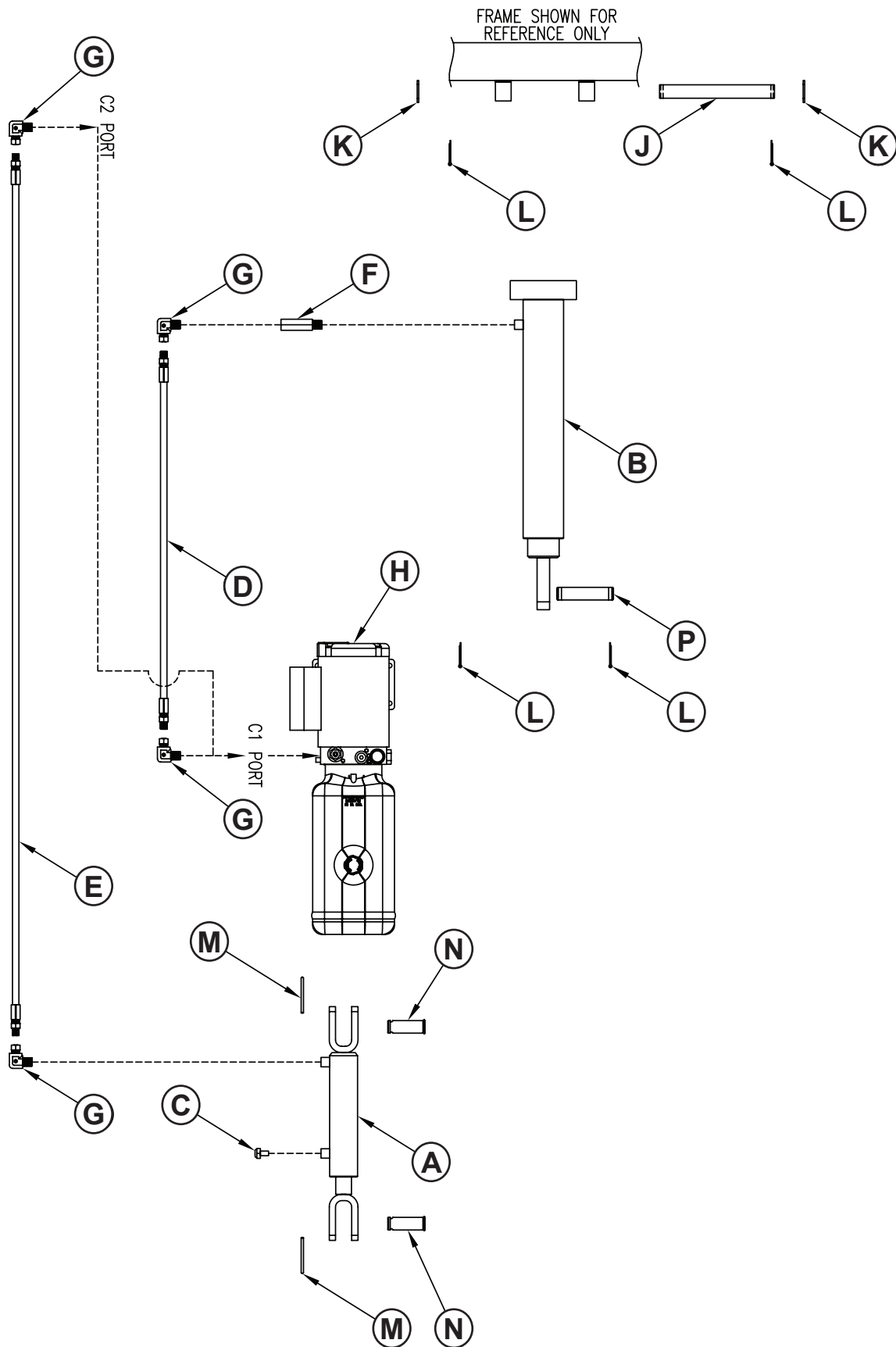

## Hydraulic Components

Item	Quantity	Part Number	Description
A	1	DOTH-2852	Cylinder, Lip, 2" Bore x 6" Stroke
B	1	0521-0211	Cylinder, Main Hoist, 2.5" Bore x 14" Stroke
C	1	DOTH-2814	Breather, Vent Plug, 3/8" Male - NPT
D	1	9904-0087	Hyd Hose, 3/8" 100R1, 33.00 Lg
E	1	9904-0115	Hyd Hose, 3/8" 100R1, 72.00 Lg, #6 JICM
F	1	DOTH-2771	Velocity Fuse, 3 GPM
G	4	0521-0044	Ftg, Elbow, 90 Deg, Male
H	1	DOTH-2854	Powerpack, 115/230v, 1ph, 50/60Hz
		DOTH-2855	Powerpack, 230/460v, 3ph, 50/60Hz
J	1	DFRA-1205	Pivot Pin, 1 OD x 9-1/8
K	2	DOTH-2205	Washer, 1-3/4 OD x 1-1/8 ID x 1/8
L	4	DOTH-2382	Pin, Cotter, 1/4 x 2
M	2	DOTH-2815	Pin, Hitch Clip
N	2	M113.264	Pin, Clevis, 1 x 2.75
P	1	DPLA-0389	Pin, Main Hoist, 1 x 4-1/2

\* Provide dock leveler serial number, voltage, phase, and options when e-mailing, calling or faxing orders.

# PARTS

## Weather Seals

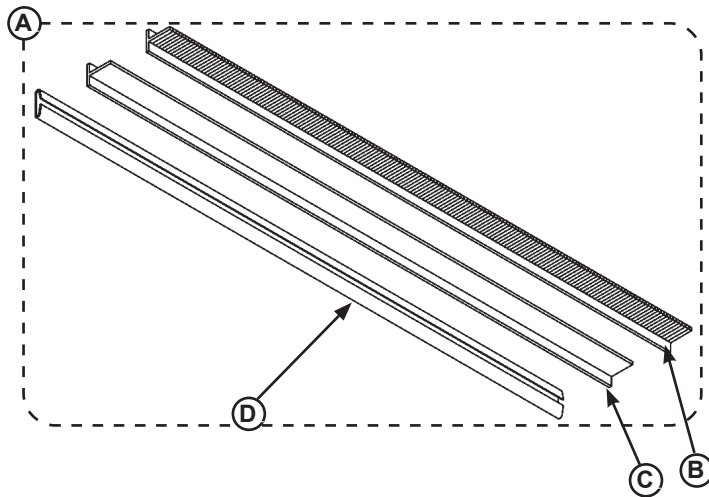

### Weather Seal Kits

Item	Quantity	Part Number	Description
A	1	DKIT-9293	Brush Kit (Includes Seal and Track), 1-1/2 in. 84" Lg. (Both Sides)
	1	DKIT-9292	Rubber Kit (Includes Seal and Track), 1-1/2 in. 84" Lg. (Both Sides)

### Individual Replacement Seals

Item	Quantity	Part Number	Description
B	1	DOTH-2822	Brush Refill, 1-1/2 in. 84" Lg.
C	1	DOTH-2824	Rubber Refill, 1-1/2 in. 84" Lg.
D	1	DOTH-2840	Replacement Channel

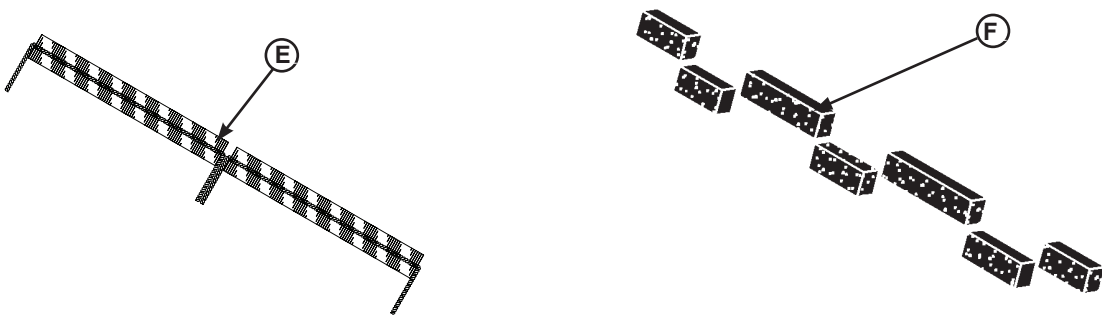

### Rear Seals

Item	Quantity	Part Number	Description
E	1	0195-0045	Rear Brush Weather Seal, Universal
F	1	0195-0046	Rear Foam Seal, Self-Adhesive, Pre-Cut, 6' Wide Levelers
		0195-0047	Rear Foam Seal, Self-Adhesive, Pre-Cut, 6.5' Wide Levelers
		0195-0048	Rear Foam Seal, Self-Adhesive, Pre-Cut, 7' Wide Levelers

\* Provide dock leveler serial number and size of platform when e-mailing, calling or faxing orders.

This page intentionally left blank.

# PARTS

## Toe Guards

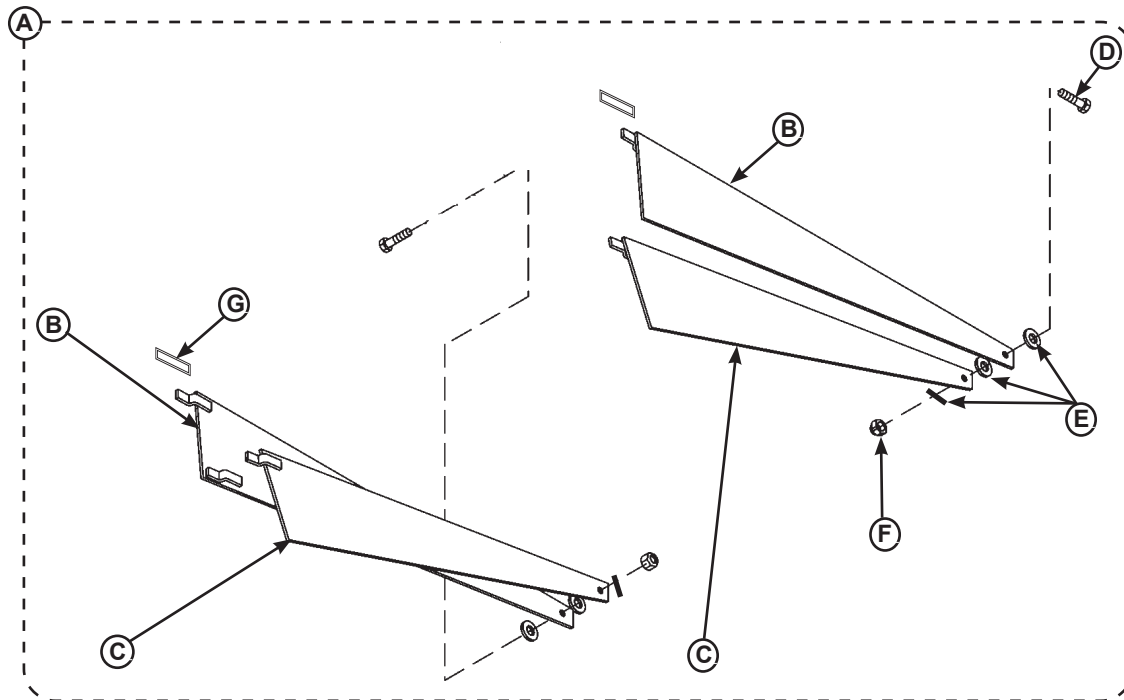

Item	Quantity	Part Number	Description
A	1	DKIT-9179	Toe Guard Kit, Sliding 6' (Includes Both Sides)
		DKIT-9180	Toe Guard Kit, Sliding 8' (Includes Both Sides)
		DKIT-9181	Toe Guard Kit, Sliding 10' (Includes Both Sides)
B	1	0014-____*	Toe Guard, Middle*
C	1	0014-____*	Toe Guard, Lower*
D	2	DOTH-2043	Cap Screw
E	6	DOTH-2207	Washer
F	2	DOTH-2131	Lock Nut
G	2	0011-0010	Platform Mounting Tab

\* Provide dock leveler serial number and size of platform when e-mailing, calling or faxing orders.



This page intentionally left blank.

# MISCELLANEOUS

---

This page intentionally left blank.

## Customer Information

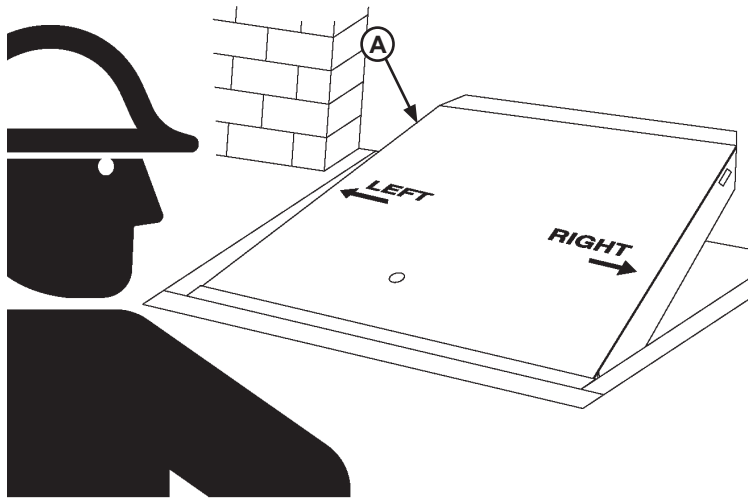

Figure 28



Figure 29

**NOTE:** Refer to Figure 28 for left/right orientation of dock leveler and Figure 29 for example of decal.

The LEVELER model/serial number decal is located on the left platform joist near the front (lip) of dock leveler (A).

When you receive your new equipment, write down the model and serial number in the form provided. This will help ensure safe keeping of the numbers in the event the model/serial number decal (A, B) becomes lost or damaged.

Also, write down Systems, LLC's order number, the company that installed the dock leveler, and the original owner's name. This will all help to identify the specific dock leveler if more information is required.

When ordering, use part numbers and description to help identify the item ordered. Do not use "item" numbers. These are only for locating the position of the parts. Always give dock leveler MODEL NUMBER and/or SERIAL NUMBER.

For service, call or contact:

Systems, LLC  
P.O. Box 309  
Germantown, WI 53022

Phone: (800) 643-5424  
Fax: (262) 255-5917

www.loadingdocksystems.com

### Dock Leveler Information

Model \_\_\_\_\_

Serial No. \_\_\_\_\_

Systems, LLC, Job No. \_\_\_\_\_

### Vehicle Restraint Information

Model \_\_\_\_\_

Serial No. \_\_\_\_\_

Systems, LLC Order No. \_\_\_\_\_

### Original Owner Information

Name \_\_\_\_\_

Address \_\_\_\_\_

\_\_\_\_\_

### Installer Information

Name \_\_\_\_\_

Address \_\_\_\_\_

\_\_\_\_\_

Date of Installation \_\_\_\_\_

## **STANDARD PRODUCT WARRANTY**

SYSTEMS, LLC warrants that its products will be free from defects in design, materials and workmanship for a period of one (1) year from the date of shipment. All claims for breach of this warranty must be made within 30 days after the defect is or can with reasonable care, be detected. In no event shall any claim be made more than 30 days after this warranty has expired. In order to be entitled to the benefits of this warranty, the product must have been properly installed, maintained and operated in accordance with all manufacturer's recommendations and/or specified design parameters and not otherwise have been subject to abuse, misuse, misapplication, acts of nature, overloading, unauthorized repair or modification, application in a corrosive environment or lack of maintenance. Periodic lubrication, adjustment and inspection in accordance with all manufacturers' recommendations are the sole responsibility of the Owner/User.

In the event of a defect, as determined by SYSTEMS LLC, covered by this warranty, SYSTEMS LLC shall remedy such defect by repairing or replacing any defective equipment or parts, bearing the cost for the parts, labor and transportation. This shall be exclusive remedy for all claims whether based on contract, negligence or strict liability.

## **WARRANTY LIMITATIONS**

THE ABOVE WARRANTIES ARE IN LIEU OF ANY OTHER WARRANTIES, WHETHER EXPRESSED OR IMPLIED, INCLUDING BUT NOT LIMITED TO ANY IMPLIED WARRANTY OF MERCHANTABILITY OR FITNESS FOR A PARTICULAR PURPOSE. SYSTEMS INC. AND ITS SUBSIDIARIES SHALL NOT IN ANY EVENT BE LIABLE TO ANYONE, INCLUDING THIRD PARTIES, FOR INCIDENTAL, CONSEQUENTIAL OR SPECIAL DAMAGES OF ANY KIND INCLUDING BUT NOT LIMITED TO, BREACH OF WARRANTY, LOSS OF USE, LOSS OF PROFIT, INTERRUPTION OF BUSINESS OR LOSS OF GOODWILL.