



A Division of Systems, LLC

MEDLF Series

Dock Leveler

Owner's/User's Manual



McGuire • Division of Systems, LLC • W194 N11481 McCormick Drive • Germantown, WI 53022
800.624.8473 • fax: 262.255.5917 • www.wbmcguire.com • techservices@loadingdocksystems.com

Printed in U.S.A.
© 2019 Systems, LLC - All Rights Reserved

Manual No. 4111-0026
Feb. 2019

Table of Contents

	Page
Precautions	
Recognize Cautionary Information	1
General Operational Precautions	1
Operational Precautions	2
Safety Decals.....	4
Placard	5
Owner's/User's Responsibilities	6
Introduction	
General Information.....	8
Component Identification.....	9
Installation	
Installation Precautions	10
Installation Overview	11
Flush Mount - Weld On.....	12
Ramp Mount - Weld/Bolt On	14
Flush Mount - Bolt On	16
Ramp Mount - Weld On w/Formed Angle	18
Formed Angle.....	20
Ramp and Face Plate.....	22
Placard Installation Instructions	24
Operation	
Operational Precautions	25
Operating Instructions	26
Maintenance	
Maintenance Precautions.....	28
Periodic Maintenance	29
Adjustments	
Spring Adjustment.....	30
Troubleshooting	
Troubleshooting.....	31
Parts	
MEDLF-Series.....	32
Torsion Spring Assembly.....	34
Operating Links.....	35
Bumpers	38
Miscellaneous	
Customer Information	41
Warranty.....	Back Cover

PRECAUTIONS

Recognize Precautionary Information

Safety-Alert Symbol



The Safety-Alert Symbol is a graphic representation intended to convey a safety message without the use of words. When you see this symbol, be alert to the possibility of death or serious injury. Follow the instructions in the safety message panel.

DANGER

The use of the word DANGER signifies the presence of an extreme hazard or unsafe practice which will most likely result in death or severe injury.

WARNING

The use of the word WARNING signifies the presence of a serious hazard or unsafe practice which could result in death or serious injury.

CAUTION

The use of the word CAUTION signifies possible hazard or unsafe practice which could result in minor or moderate injury.

NOTICE

The use of the word NOTICE indicates information considered important, but not hazard-related, to prevent machine or property damage.

SAFETY INSTRUCTIONS

Indicates a type of safety sign, or separate panel on a safety sign, where safety-related instructions or procedures are described.

General Operational Precautions

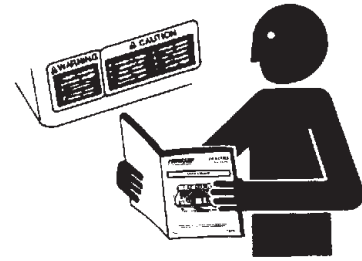

Read and understand the Owner's/User's Manual and become thoroughly familiar with the equipment and its controls before operating the dock leveling device.

Never operate a dock leveler or transport vehicle restraint while a safety device or guard is removed or disconnected.

Never remove DANGER, WARNING, or CAUTION signs, Placards or Decals on the equipment unless replacing them.

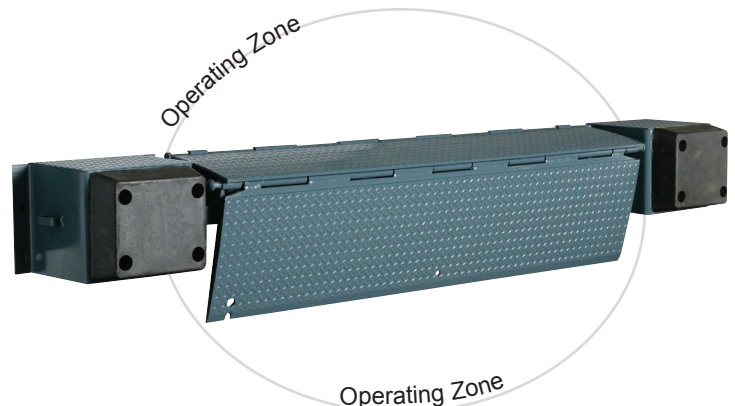

Figure 1

Do not start the equipment until all unauthorized personnel in the area have been warned and have moved outside the operating zone (Figure 1).

Remove any tools or foreign objects from the operating zone before starting.

Keep the operating zone free of obstacles that could cause a person to trip or fall.



WARNING: This product can expose you to chemicals including lead, which are known to the State of California to cause cancer or birth defects or other reproductive harm. For more information go to www.P65Warnings.ca.gov

PRECAUTIONS

Operational Precautions



Learn the safe way to operate this equipment. Read and understand the manufacturer's instructions. If you have any questions, ask your supervisor.

DANGER



Stay clear of dock leveling device when transport vehicle is entering or leaving area.



Do not move or use the dock leveling device if anyone is under or in front of it.



Keep hands and feet clear of pinch points. Avoid putting any part of your body near moving parts.

WARNING



Chock/restrain all transport vehicles. Never remove the wheel chocks or release the restraining device until loading or unloading is finished, and transport driver has been given permission to drive away.



Do not use a broken or damaged dock leveling device or restraining device. Make sure proper service and maintenance procedures have been performed before using.



Make sure lip overlaps onto transport vehicle bed at least 4 in. (102 mm).

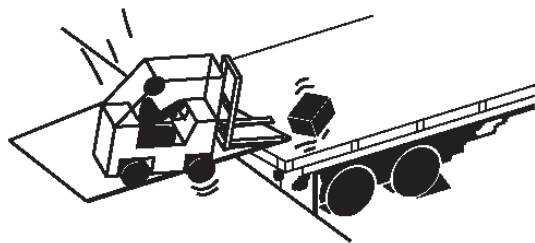

Keep a safe distance from both side edges.

Operational Precautions

! WARNING



Do not use dock leveling device if transport vehicle is too high or too low.

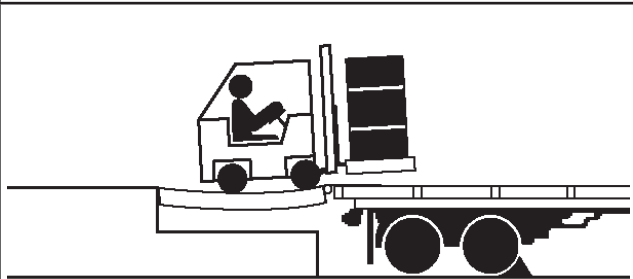

Do not overload the dock leveling device.

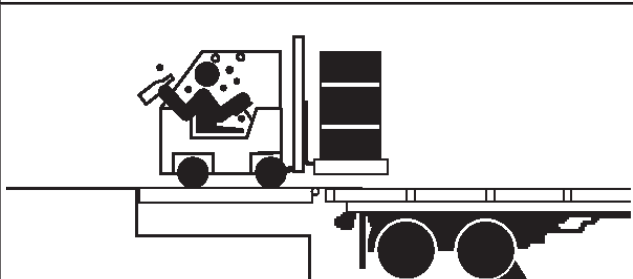

Do not operate any equipment while under the influence of alcohol or drugs.

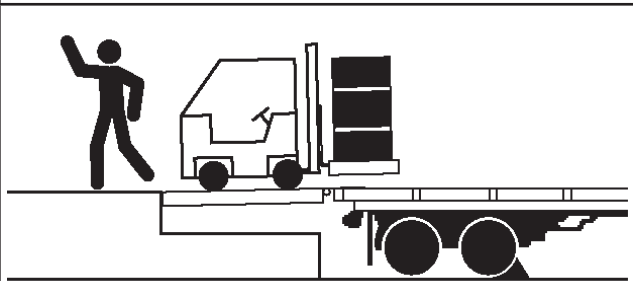

Do not leave equipment or material unattended on dock leveling device.

PRECAUTIONS

Safety Decals

①

⚠ DANGER	SAFETY INFORMATION
<p>Unsupported dock leveler ramps can lower unexpectedly.</p> <p>Before allowing vehicle to leave the dock always:</p> <ul style="list-style-type: none"> • Ensure no equipment, material or people are on dock leveler. • Return dock leveler to its stored position at dock level. 	<p>OPERATION</p> <ol style="list-style-type: none"> 1. Read and follow all instructions and warnings in owner's/user's manual. 2. Use of dock leveler restricted to trained operators. 3. Always chock trailer wheels or engage truck restraint before operating dock leveler or beginning to load or unload. 4. Never use hands or equipment to move ramp or lip. 5. Before actuating dock leveler: <ul style="list-style-type: none"> • Ensure trailer is backed in against bumpers. • Remove any end loads if required. • Check trailer alignment to avoid lip interference. If lip does not lower to trailer bed, reposition vehicle. 6. Ensure truck bed supports extended lip or leveler frame supports the ramp before driving on ramp. <p>MAINTENANCE/SERVICE</p> <ol style="list-style-type: none"> 1. Read and follow all instructions, warnings and maintenance schedules in the owner's/user's manual. 2. Maintenance/Service of dock leveler restricted to trained personnel. 3. Place barriers on the driveway and dock floor to indicate service work is being performed. 4. DO NOT ENTER PIT unless dock leveler is securely supported by maintenance prop. 5. If electrically powered turn off and use OSHA lockout/tagout procedures. <p>OPERATION</p> <ol style="list-style-type: none"> 7. Stay clear of hinges and front and sides of moving dock leveler. 8. N e v e r u s e d a m a g e d o r m a l f u n c t i o n i n g d o c k l e v e l e r . Report problems immediately to supervisor.
<p>Failure to follow posted instructions will result in death or serious injury. Call 262.255.1510 for replacement placards, warning labels, or owner's/user's manuals. 1751-0730 Rev. B</p>	

①

⚠ DANGER	SAFETY INFORMATION
<p>Unsupported dock leveler ramps can lower unexpectedly.</p> <p>Before allowing vehicle to leave the dock always:</p> <ul style="list-style-type: none"> • Ensure no equipment, material or people are on dock leveler. • Return dock leveler to its stored position at dock level. 	<p>OPERATION</p> <ol style="list-style-type: none"> 1. Read and follow all instructions and warnings in owner's/user's manual. 2. Use of dock leveler restricted to trained operators. 3. Always chock trailer wheels or engage truck restraint before operating dock leveler or beginning to load or unload. 4. Never use hands or equipment to move ramp or lip. 5. Before actuating dock leveler: <ul style="list-style-type: none"> • Ensure trailer is backed in against bumpers. • Remove any end loads if required. • Check trailer alignment to avoid lip interference. If lip does not lower to trailer bed, reposition vehicle. 6. Ensure truck bed supports extended lip or leveler frame supports the ramp before driving on ramp. <p>MAINTENANCE/SERVICE</p> <ol style="list-style-type: none"> 1. Read and follow all instructions, warnings and maintenance schedules in the owner's/user's manual. 2. Maintenance/Service of dock leveler restricted to trained personnel. 3. Place barriers on the driveway and dock floor to indicate service work is being performed. 4. DO NOT ENTER PIT unless dock leveler is securely supported by maintenance prop. 5. If electrically powered turn off and use OSHA lockout/tagout procedures. <p>OPERATION</p> <ol style="list-style-type: none"> 7. Stay clear of hinges and front and sides of moving dock leveler. 8. N e v e r u s e d a m a g e d o r m a l f u n c t i o n i n g d o c k l e v e l e r . Report problems immediately to supervisor.
<p>Failure to follow posted instructions will result in death or serious injury. Call 262.255.1510 for replacement placards, warning labels, or owner's/user's manuals. 1751-0730 Rev. B</p>	

1751-0730

③

⚠ DANGER
<p>Ramp swings toward you.</p> <p>Stand Clear.</p> <p>Use maintenance strut while servicing.</p> <p>Failure to do so will result in death or serious injury.</p> <p style="font-size: x-small; margin-top: 10px;">Refer to owner's/user's manual for proper procedure 1751-0763 Rev. A</p>

1751-0763

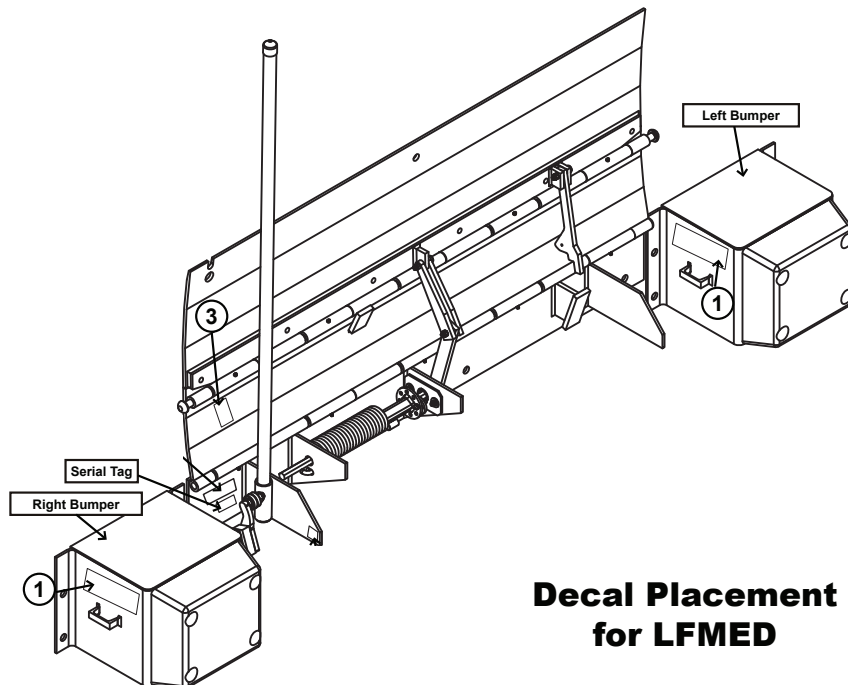

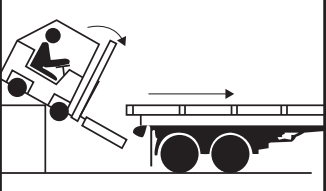
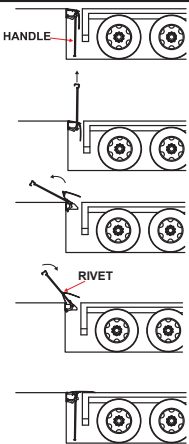
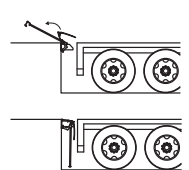





Figure 2

Decal Placement for LFMED

Placard

 <h1 style="margin: 0;">DANGER</h1>	<h1 style="margin: 0;">OPERATING INSTRUCTIONS</h1>
 <ul style="list-style-type: none"> Read and follow all instructions, warnings, and maintenance schedules in the manual and on placards. Operation and servicing of dock leveler is restricted to authorized personnel. <ul style="list-style-type: none"> Always chock transport vehicle wheels or engage vehicle restraint and set parking brakes before operating dock leveler or beginning to load or unload. Before activating dock leveler, check to make sure the transport vehicle is positioned squarely against dock bumpers. Ensure lip will avoid contact with transport vehicle frame, sides and cargo during dock leveler activation. If contact is likely or observed, reposition transport vehicle. Ensure the transport vehicle floor supports extended lip or the leveler frame (lip keepers or below dock endload supports) supports the ramp before driving on ramp. Stay clear of hinges and front and sides of moving dock leveler. Never use hands or equipment to move the ramp or lip. Never use damaged or malfunctioning dock leveler. Report problems immediately to supervisor. Always store dock leveler and remove people, material, and equipment from ramp before vehicle leaves the dock. DO NOT ENTER PIT unless dock leveler is securely supported and proper lockout/tagout procedures have been completed. See "Maintenance Precautions" in Owner's/User's Manual. <p>FAILURE TO FOLLOW THESE INSTRUCTIONS WILL RESULT IN DEATH OR OTHER SERIOUS INJURY.</p>	<h3 style="background-color: black; color: white; padding: 2px;">NL, TS, MEDLF EDGE-OF-DOCK LEVELERS</h3> <div style="border-bottom: 1px solid black; padding-bottom: 10px;"> <h4 style="color: red; margin: 0;">NORMAL OPERATION</h4>  <ol style="list-style-type: none"> Grasp the captured operating handle and raise to its full extended length. Then pull handle toward you, rotating center plate back past vertical. Actuate the leveler by pushing forward on handle against the rivet rotating leveler out onto transport vehicle. The leveler will lower until lip is resting on the transport vehicle. Return handle to the stored position. </div> <div style="border-bottom: 1px solid black; padding-bottom: 10px;"> <h4 style="color: red; margin: 0;">STORING LEVELER</h4>  <ol style="list-style-type: none"> Extend the handle to its full extended length, then pull handle toward you until lip just clears the bed of the transport vehicle. Slowly allow handle to come forward until leveler is lowered to the stored position. Return handle to the stored position. <p>NOTE: If transport vehicle departs before leveler is stored, leveler will automatically return to stored position.</p> </div> <div style="padding-bottom: 10px;"> <h4 style="color: red; margin: 0;">BELOW DOCK ENLOADING</h4>  <ul style="list-style-type: none"> Remove any endloads while leveler is in the stored position. </div>
 <p>Scan to view our owner's/user's manuals online. www.LoadingDockSystems.com 1.800.643.5424 Call for additional placards, or manuals, or with questions regarding proper use, maintenance, and repair of dock leveler.</p> <p> WARNING: CANCER AND REPRODUCTIVE HARM www.P65Warnings.ca.gov</p> <p>1751-0876</p>	 <p>1751-0876 Rev D</p>

OWNER'S/USER'S RESPONSIBILITIES

- 1) The manufacturer shall provide to the initial purchaser and make the following information readily available to the owners/users and their agents, all necessary information regarding Safety Information, Operation, Installation and Safety Precautions, Recommended Initial and Periodic Inspections Procedures, Planned Maintenance Schedule, Product Specifications, Troubleshooting Guide, Parts Break Down, Warranty Information, and Manufacturers Contact Information, as well as tables to identify the grade(slope) for all variations of length or configuration of the dock leveling device and information identifying the maximum uncontrolled drop encountered when sudden removal of support while in the working range of the equipment.
- 2) When selecting loading dock safety equipment, it is important to consider not only present requirements but also future plans and any possible adverse conditions, environmental factors or usage. The owners/users shall provide application information to the manufacturer to receive recommendations on appropriate equipment specifications and capacity.
- 3) The owner/user must see all nameplates, placards, decals, instructions and posted warnings are in place and legible and shall not be obscured from the view of the operator or maintenance personnel for whom such warnings are intended for. Contact manufacturer for any replacements.
- 4) Dock leveling devices may become hazardous if the manufacturer's instructions regarding modifications or adjustments are not followed. Modifications or alterations of dock leveling devices shall only be made with prior written approval from the original manufacturer. These changes shall be in conformance with all applicable provisions of the MH30.1 standard and shall also satisfy all safety recommendations of the original equipment manufacturer of the particular application.
- 5) The owner/user should recognize the inherent dangers of the interface between the loading dock and the transport vehicle. The owner/ user should, therefore, train and instruct all operators in the safe operation and use of the loading dock equipment in accordance with manufacturer's recommendations and industry standards. Effective operator training should also focus on the owner's/user's company policies, operating conditions and the manufacturer's specific instructions provided with the dock leveling device. Maintaining, updating and retraining all operators on safe working habits and operation of the equipment, regardless of previous experience, should be done on a regular basis and should include an understanding and familiarity with all functions of the equipment. Owners/users shall actively maintain, update and retrain all operators on safe working habits and operations of the equipment.
- 6) An operator training program should consist of, but not necessarily be limited to, the following:
 - a) Select the operator carefully. Consider the physical qualifications, job attitude and aptitude.
 - b) Assure that the operator reads and fully understands the complete manufacturer's owners/users manual.
 - c) Emphasize the impact of proper operation upon the operator, other personnel, material being handled, and equipment. Cite all rules and why they are formulated.
 - d) Describe the basic fundamentals of the dock leveling device and components design as related to safety, e.g., mechanical limitation, stability, functionality, etc.
 - e) Introduce the equipment. Show the control locations and demonstrate its functions. Explain how they work when used properly and maintained as well as problems when they are used improperly.
 - f) Assure that the operator understands the capacity rating, nameplate data, placards and all precautionary information appearing on the dock leveling device.
 - g) Supervise operator practice of equipment.
 - h) Develop and administer written and practical performance tests. Evaluate progress during and at completion of the course.
 - i) Administer periodic refresher courses. These may be condensed versions of the primary course and include on-the-job operator evaluation.

OWNER'S/USER'S RESPONSIBILITIES

- 7) Loading dock safety equipment should never be used outside of its vertical working range, or outside the manufacturer's rated capacity. It shall also be compatible with the loading equipment and other conditions related to dock activity. Please consult the manufacturer if you have any questions as to the use, vertical working range or capacity of the equipment. Only properly trained and authorized personnel should operate the equipment.
- 8) It is recommended that the transport vehicle is positioned as close as practical to the dock leveling device and in contact with both bumpers. When an industrial vehicle is driven on or off a transport vehicle during loading and unloading operations, the transport vehicle parking brakes shall be applied and wheel chocks or a restraining device that provides equal or better protection of wheel chocks shall be engaged. Also, whenever possible, air-ride suspension systems should have the air exhausted prior to performing said loading and unloading operations.
- 9) When goods are transferred between the loading dock and a trailer resting on its support legs/ landing gear instead of a tractor fifth wheel or converter dolly, it is recommended that an adequate stabilizing device or devices shall be utilized at the front of the trailer.
- 10) In order to be entitled to the benefits of the standard product warranty, the dock safety equipment must have been properly installed, maintained and operated in accordance with all manufacturer's recommendations and/ or specified design parameters and not otherwise have been subject to abuse, misuse, misapplication, acts of nature, overloading, unauthorized repair or modification, application in a corrosive environment or lack of maintenance. Periodic lubrication, adjustment and inspection in accordance with all manufacturers' recommendations are the sole responsibility of the owner/user.
- 11) Manufacturer's recommended maintenance and inspection of all dock leveling devices shall be performed in conformance with the following practices: A planned maintenance schedule program must be followed, only trained and authorized personnel shall be permitted to maintain, repair, adjust and inspect dock leveling devices, and only the use of original equipment manufacturer parts, manuals, maintenance instructions, labels, decals and placards or their equivalent. Written documentation of maintenance, replacement parts or damage should be kept. In the event of damage, notification to the manufacturer is required.
- 12) Loading dock devices that are structurally damaged or have experienced a sudden loss of support while under load, such as might occur when a transport vehicle is pulled out from under the dock leveling device, shall be removed from service, inspected by a manufacturer's authorized representative, and repaired or replaced as needed or recommended by the manufacturer before being placed back in service.

INTRODUCTION

General Information

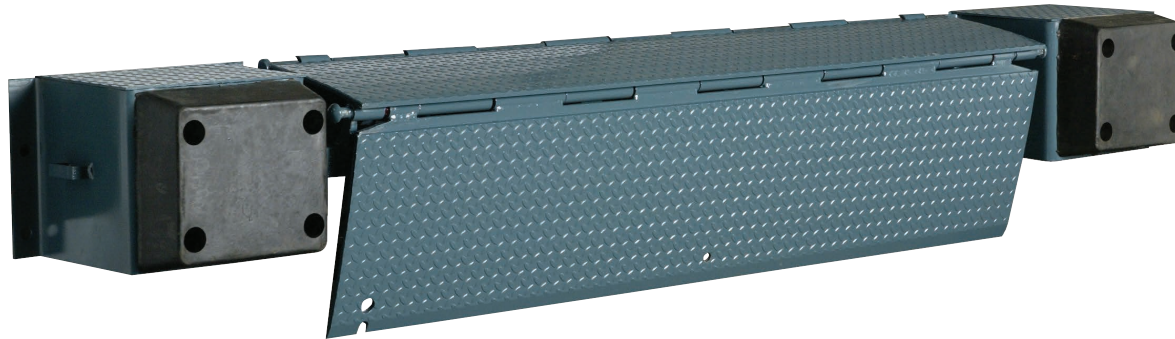

Figure 3

This manual provides current information on the MEDLF-series dock levelers (Figure 3). Due to ongoing product improvement, some parts may have changed, along with operation and troubleshooting methods. This manual describes these changes where applicable.

McGuire Edge-of-Dock Levelers mount directly to the dock face and provide a recommended working range of +/-3" and a maximum operating range of +/-5" above or below dock.

Mechanically-operated edge-of-dock levelers are the largest selling edge-of-dock levelers in the industry. Careful engineering and rugged construction ensure extended life. Operation is safe and easy.

MEDLF dock levelers are available in the sizes, weight capacities, and options listed in the following tables.

Call McGuire to discuss available options to meet your specific needs.

Dimensions and Capacities			
Model # -	Deck - Width	Total Unit Width	Comparative Industry Rating
MEDLF-66	66"	104"	20,000
MEDLF-72	72"	110"	25,000
MEDLF-78	78"	116"	30,000
MEDLF-84	84"	122"	35,000 (N/A for MEDLF-78 & 84)

Technical Service at 800-643-5424 or techservices@loadingdocksystems.com

Component Identification

Inspect package and all components. Report any missing or damaged items immediately and note on the shipping Bill Of Lading (BOL).

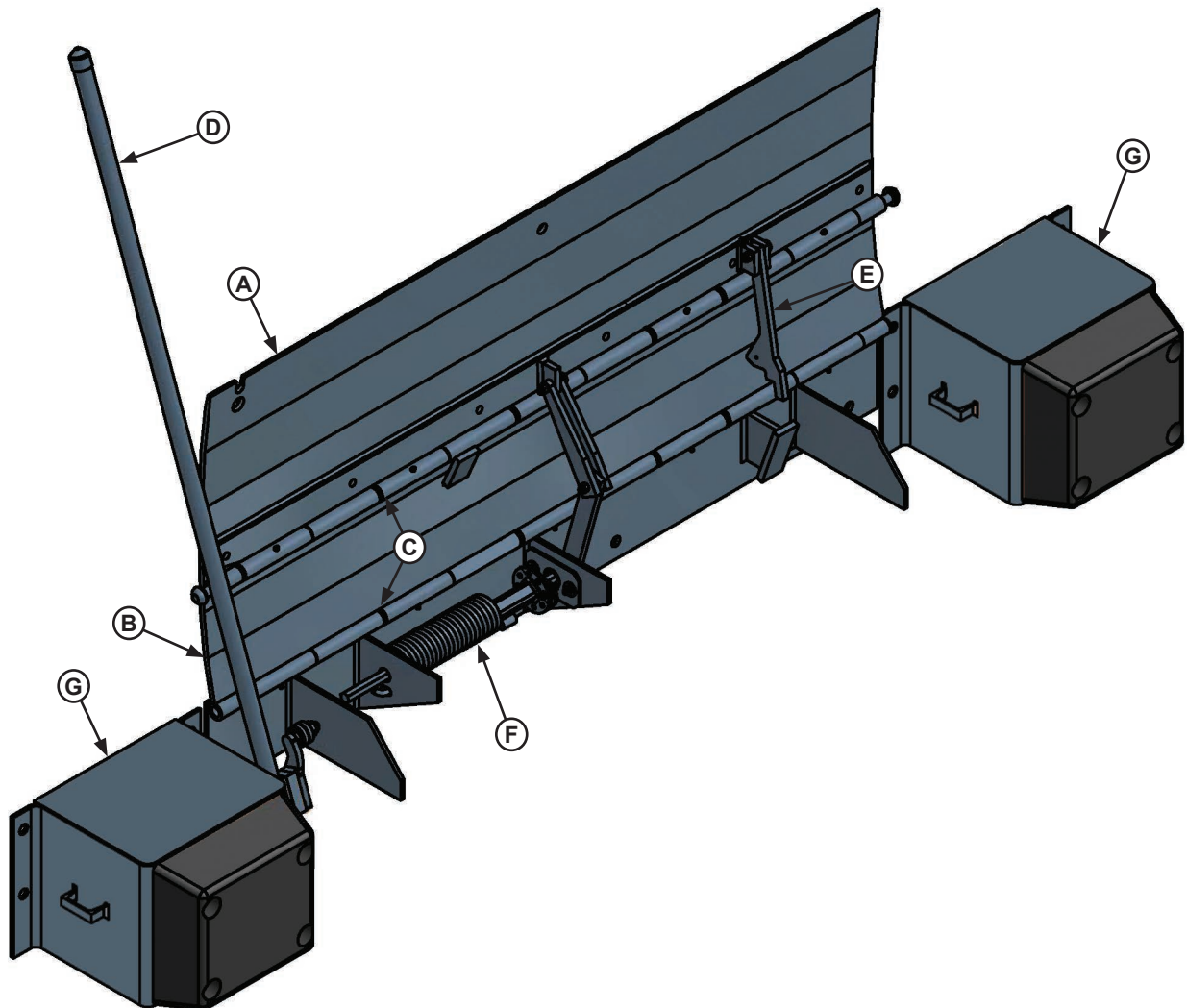

Figure 4

A — Lip Plate
B — Center Plate
C — Hinge Area

D — Lifting Lever
E — Extend Link Arm
F — Torsion Spring (TS only)

G — Bumper Blocks (2 used)

INSTALLATION

Installation Precautions

DANGER

It is recommended and good safety practice to use an additional means to support the dock platform and lip anytime when physically working in front of or under the dock leveler. This additional means may include, but is not limited to a boom truck, fork truck, stabilizing bar or equivalent.

WARNING

Post safety warnings and barricade the work area at dock level and ground level to prevent unauthorized use of the dock leveler before installation has been completed.

WARNING

DO NOT grind or weld if hydraulic fluid or other flammable liquid is present on the surface to be ground or welded.

DO NOT grind or weld if uncontained hydraulic fluid or other flammable liquid is present. Stray sparks can ignite spills or leaks near the work area. Always clean up the oil leaks and spills before proceeding with grinding or welding.

Always keep a fire extinguisher of the proper type nearby when grinding or welding.

WARNING

A hard hat or other applicable head protection should always be worn when working under or around a dock leveler.

Always stand clear of platform lip when working in front of the dock leveler.

CAUTION

Only trained installation professionals with the proper equipment should install this product.

INSTALLATION

Installation Overview

WARNING

Securely block or support ramp and lip when in vertical positions. Lack of proper bracing can result in ramp dropping during adjustment or installation.

NOTICE

Springs must be adjusted after install to ensure correct operation and preserve unit warranty.

Note: This is a generic overview of the installation steps required. See full installation instructions on pages 12-24 for different installation types and all steps.

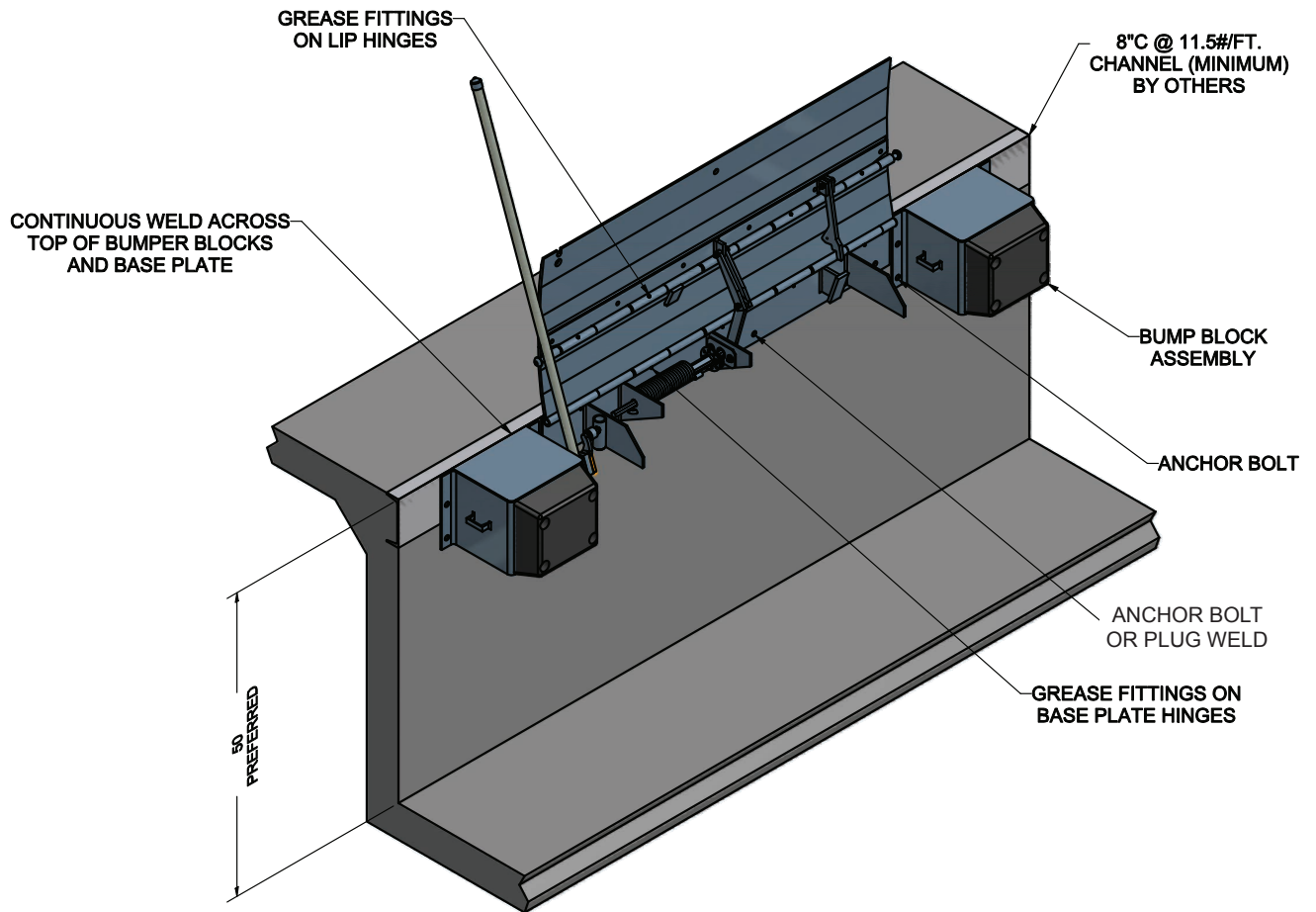

Figure 5

INSTALLATION

Flush Mount - Weld On

A flush mount weld on application is used when an 8" wide (minimum) embed channel is securely anchored into the concrete at the dock edge, and the dock height is adequate.

1. Remove all existing bumper material and protruding objects from dock edge. Clean and sweep dock edge free of debris and flammable chemicals before installing unit.
2. At chosen location for Edge-of-Dock leveler, locate the center of space and mark a point half of the base plate width to the left and right.
3. Using a proper lifting device, raise and position leveler on dock face with the top of the base plate being 1/4" below the top of the embedded channel. Position ends of base plate to match up with marks made previously.
4. Tack weld base plate to dock steel on left hand end of the leveler. Check right hand end of base plate, ensure that end is against dock steel and that the top of the base plate is still 1/4" below the top of the embedded channel. Tack right hand end to dock steel.
5. Position bump blocks out approximately 5/8" from the edge of the inside flange of the bump block to the end of the base plate. This will allow for vertical welding of both the base plate and the bump block flange back to the dock steel. Top of the bump block cover plate should be flush with the top of the embed channel. Tack weld bump blocks to dock steel.
6. Check the positioning of the base plate and the bump blocks.
7. Complete bumper install:
 - a. Apply continuous weld across top of each bumper. Skip welding is acceptable to prevent warpage, but complete weld must be completed.
 - a. Plug weld mounting holes to imbed or drill holes 5/8" dia. by 5" deep in concrete. Install 5/8 x 4-3/4 anchor bolts with washers.
8. Finish welding the base plate:
 - a. Weld the top of end base plate and first hinge to imbed.
 - b. Weld top of each hinge tube to imbed.
 - c. Weld vertically along each end of base plate.
 - d. Plug weld all holes in base plate.
9. Installer must remove all welding slag, and repaint welded areas.
10. Installer must adjust springs on all mechanical Edge of Dock levelers to provide desired tension for smooth operation. See page 30.

Flush Mount - Weld On (continued)

WARNING

Securely block or support ramp and lip when in vertical positions. Lack of proper bracing can result in ramp dropping during adjustment or installation.

NOTICE

Springs must be adjusted after install to ensure correct operation and preserve unit warranty.

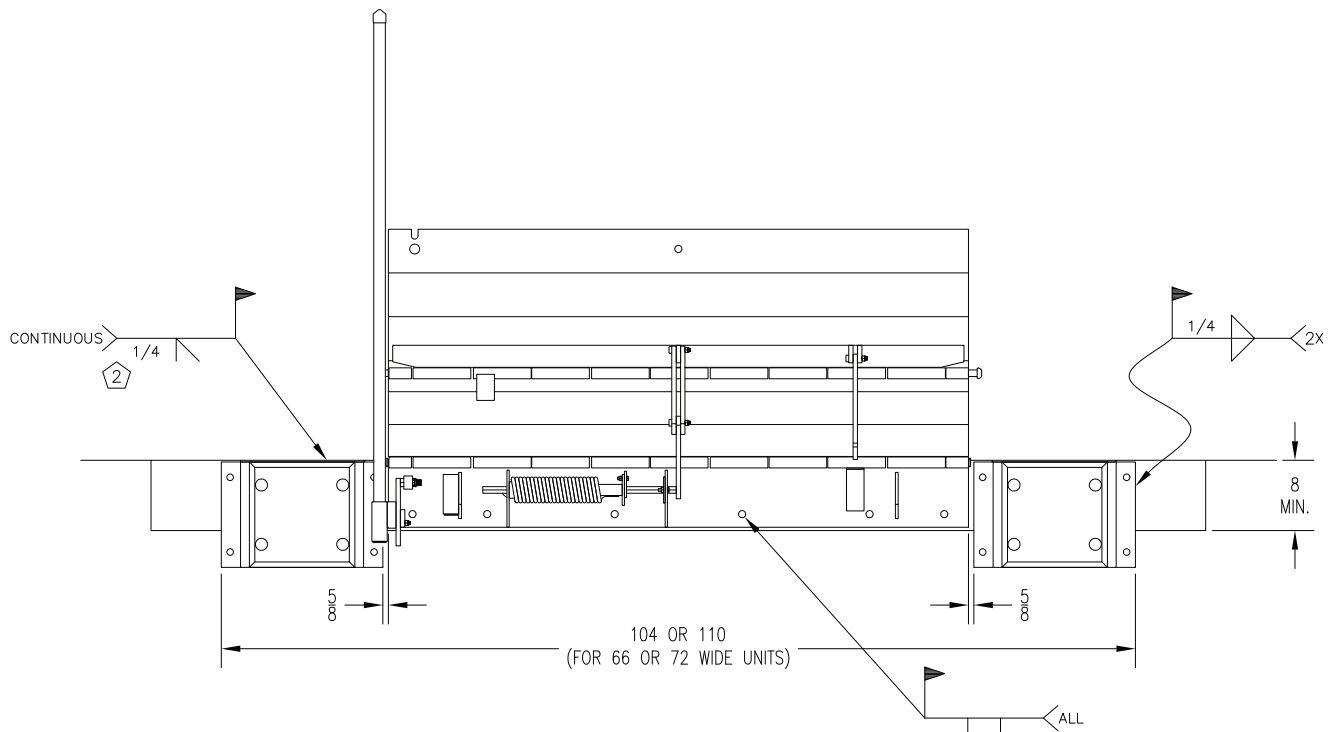

Figure 6

Note:

1. Top of base plate to be 1/4" below top of dock floor and embedded channel to create level transition when installation is complete.
2. Apply continuous bevel weld across both bumpers and length of base plate.

INSTALLATION

Ramp Mount - Weld/Bolt On

A ramp mount weld on application is used when adequate dock steel is securely anchored in the concrete at the dock edge, but the existing dock height is too low and the dock leveler must be installed above this height to correct this situation.

1. Remove all existing bumper material and protruding objects from dock edge. Clean and sweep dock edge free of debris and flammable chemicals before installing unit.
2. At chosen location for Edge of Dock leveler, locate the center of space and mark a point half of the base plate width to the left and right.
3. At the points marked to each side of center, measure and mark points 7 - 3/4" below dock level less height the unit is to be raised to locate bottom of base plate. This will locate the top of the base plate X" above dock level.
4. Using a proper lifting device, raise and position the leveler base plate to marked position. While holding base plate tight against dock face, tack weld securely to dock steel on left hand end of leveler. Check right hand end of base plate, ensure that end is against dock steel and that the bottom of the base plate is even with the marks made previously. Tack right hand end to dock steel. Support unit until final welding is ready to complete.
5. Position bump blocks out approximately 5/8" out from the edge of the inside flange of the bump block to the end of the base plate. Position the top of the tread cover plate on the bump blocks to be flush with the top of the base plate. Tack weld bump blocks to dock steel.
6. Operate the leveler through operating cycle check for binding. if binding occurs readjust leveler.
7. Complete bumper install:
 - a. Apply continuous weld across top of each bumper. Skip welding is acceptable to prevent warpage, but complete weld must be completed.
 - b. Plug weld mounting holes to imbed or drill holes 5/8" dia. by 5" deep in concrete. Install 5/8 x 4-3/4 anchor bolts with washers.
8. Finish welding the base plate:
 - a. Weld the top of end base plate and first hinge to imbed.
 - b. Weld top of each hinge tube to imbed.
 - c. Weld vertically along each end of base plate.
 - d. Fully plug weld all holes in base plate.
9. Place steel ramp plate in position, flush with top backside of base plate. Mark along full length of back edge of ramp plate. Slide ramp plate forward over dock leveler the width of bushing tool, approximately 2".
10. Place bushing tool on marked line at each end of ramp to ensure proper alignment at both ends. A Skil Roto Hammer #736 or similar tool is recommended.
11. Using the back edge of the ramp plate as a guide, groove concrete approximately 3/4" deep by 2" wide, and should be the entire length of ramp plate.
12. Slide ramp plate back into position with the top of the ramp plate flush with the top of the base plate. Tack weld each end and center of ramp plate to base plate.
13. Using ramp plate as a guide drill (9) 5/8" dia. by 5" deep holes. Install anchor bolts per manufacturers specifications, and tighten securely. Weld anchor bolt nuts to ramp plate using a 1/4" fillet weld all the way around the nut. Cut off any portion of the anchor bolt exposed through the nut, and plug weld around the top of the nut to the anchor bolt. Ensure the top of the nuts are well rounded for smooth rollover.
14. Installer must remove all welding slag, and repaint welded areas.
15. Installer must adjust springs on all mechanical Edge of Dock levelers to provide desired tension for smooth operation. See page 30.

Ramp Mount - Weld/Bolt On (continued)

WARNING

Securely block or support ramp and lip when in vertical positions. Lack of proper bracing can result in ramp dropping during adjustment or installation.

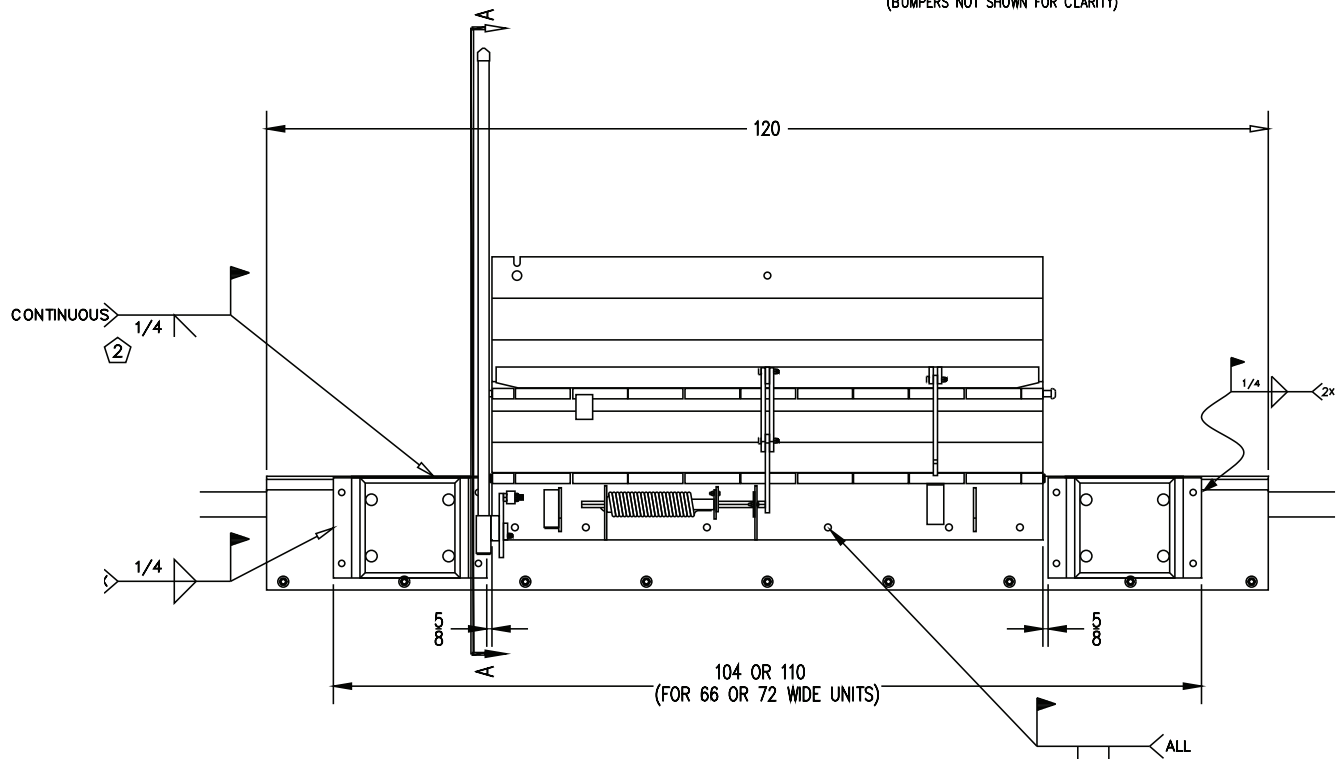
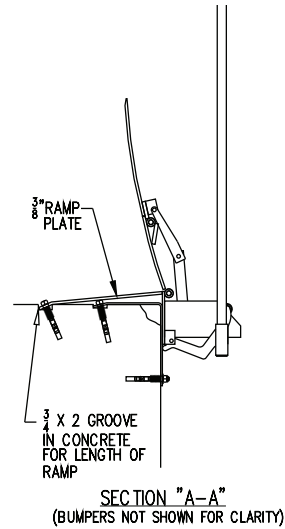

Figure 7

Note:

1. Top of base plate and bumper cover plate to be flush with top of dock floor and embedded channel.
2. Apply continuous bevel weld across both bumpers and length of base plate.
3. To figure ramp plate length, need 12" ramp for every 1-1/2" of rise to ramp.

INSTALLATION

Flush Mount - Bolt On

A flush mount bolt on application is used when there is no steel on dock edge, and the dock height is adequate. Additional steel ramp plate and bolting is required with this type of installation.

1. Remove all existing bumper material and protruding objects from dock edge. Clean and sweep dock edge free of debris and flammable chemicals before installing unit.
2. At chosen location for Edge of Dock leveler, locate the center of space and mark a point half of the base plate width to the left and right.
3. At the points marked to each side of center, measure and mark points 7-1/2" below dock level (for 1/4" ramp plate) to locate position for bottom of base plate. This position will place the top of the base plate 1/4" above the dock floor. This position will vary with ramp plate thickness.
4. Mark line connecting these points and position support angles. Position angles as shown in installation drawing provided. Mark center of holes in each of the support angles.
5. At center marks, drill holes 5/8" dia. by 5" deep in concrete. Install anchor bolts with washers through support angles into holes in concrete. Tighten bolts until support angles are secure. Follow anchor manufacturers installation instructions for proper installation.
6. Using a proper lifting device, raise and position the leveler base plate to marked position, while resting on the support angles. While holding base plate tight against dock face, tack weld securely to support angles.
7. Drill 5/8" dia. by 5" deep holes in concrete through holes in base plate, and install anchor bolts with washers and tighten securely.
8. Position bump blocks out approximately 5/8" out from the edge of the inside flange of the bump block to the end of the base plate. Position the top of the tread cover plate on the bump blocks to be 1/4" above dock level. Note that this placement will vary with ramp plate thickness. Mark centers of holes in bump block flanges.
9. Drill 5/8" dia. by 5" deep holes at center marks. Reposition bump blocks, insert anchor bolts with washers and tighten securely to dock face.
10. Place steel ramp plate in position, flush with top backside of base plate. Mark along full length of base edge of ramp plate. Slide ramp plate forward over dock leveler the width of brushing tool, approximately 2".
11. Place brushing tool on marked line at each end of ramp to ensure proper alignment at both ends. A Skil Roto Hammer #736 or similar tool is recommended.
12. Using the back edge of the ramp plate as a guide, groove concrete approximately 5/8" deep by 2" wide, and should be the entire length of ramp plate.
13. Slide ramp plate back into position with the top of the ramp plate flush with the top of the base plate. Tack weld each end and center of ramp plate to base plate.
14. Using ramp plate as a guide drill (9) 5/8" dia. by 5" deep holes. Install anchor bolts per manufacturers specifications, and tighten securely. Weld anchor bolt nuts to ramp plate using a 1/4" fillet weld all the way around the nut. Cut off any portion of the anchor bolt exposed through the nut, and plug weld around the top of the nut to the anchor bolt. Ensure the top of the nuts are well rounded for smooth rollover.
15. Complete bumper install:
 - a. Apply continuous weld across top of each bumper. Skip welding is acceptable to prevent warpage, but complete weld must be completed.
 - b. Drill holes 5/8" dia. by 5" deep in concrete. Install 5/8 x 4-3/4 anchor bolts with washers.
16. Finish welding the base plate:
 - a. Weld the top of end base plate and first hinge to the ramp plate.
 - b. Weld top of each hinge tube to the ramp plate.
17. Finish mounting the base plate. Drill holes 5/8" dia. by 5" deep in concrete. Install 5/8 x 4-3/4 anchor bolts with washers.
18. Installer must remove all welding slag, and repaint welded areas.
19. Installer must adjust springs on all mechanical Edge of Dock levelers to provide desired tension for smooth operation. See page 30.

Flush Mount - Bolt On (continued)

WARNING

Securely block or support ramp and lip when in vertical positions. Lack of proper bracing can result in ramp dropping during adjustment or installation.

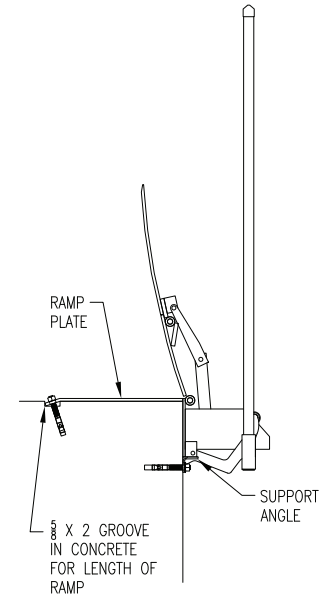

SECTION "A-A"
(BUMPER NOT SHOWN FOR CLARITY)

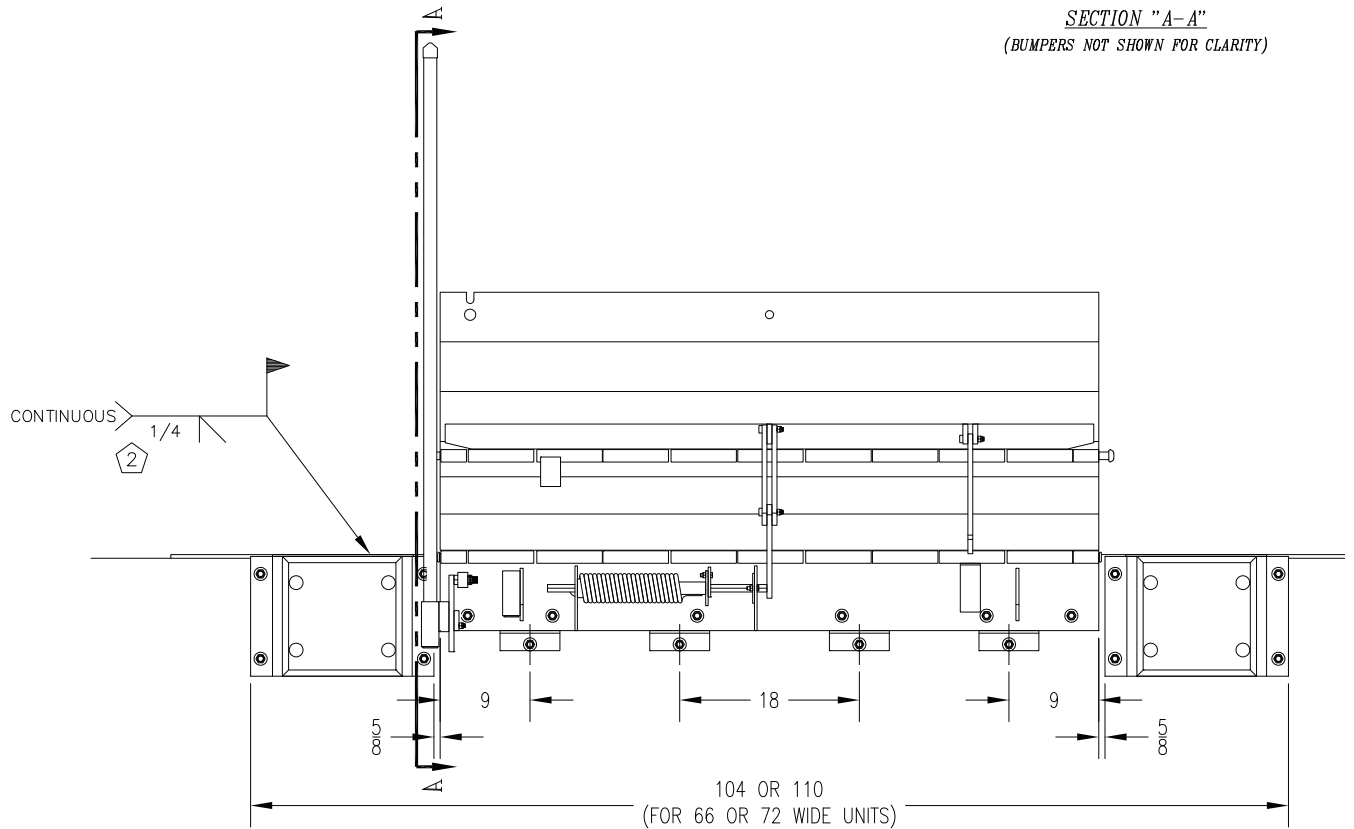

Figure 8

Note:

1. Top of base plate and bumper cover plate to be flush with top of dock floor and embedded channel.
2. Apply continuous bevel weld across both bumpers and length of base plate.

INSTALLATION

Ramp Mount - Weld On w/Formed Angle

A ramp mount-weld on used with a formed angle application is used when dock edge is damaged, there is no dock steel securely anchored into the concrete, and the dock height is too low and leveler must be installed above this height to correct this situation.

1. Remove all existing bumper material and protruding objects from dock edge. Clean and sweep dock edge free of debris and flammable chemicals before installing unit.
2. Review and follow formed angle installation instructions prior to leveler installation. See Page 20, Figure 10.
3. At chosen location for Edge of Dock leveler, locate the center of space and mark a point half of the base plate width to the left and right.
4. At the points marked to each side of center, measure and mark points 7-3/4" below dock level less height the unit is to be raised to locate bottom of base plate. This will locate the top of the base plate "X" above dock level.
5. Using a proper lifting device, raise and position the leveler base plate to marked position. While holding base plate tight against dock face, tack weld securely to dock steel on left hand end of leveler. Check right hand end of base plate, ensure that end is against dock steel and that the bottom of the base plate is even with the marks made previously. Tack right hand end to dock steel. Support unit until final welding is ready to complete.
6. Position bump blocks out approximately 5/8" out from the edge of the inside flange of the bump block to the end of the base plate. Position the top of the tread cover plate on the bump blocks to be flush with the top of the base plate. Tack weld bump blocks to dock steel.
7. Place steel ramp plate in position, flush with top backside of base plate. Mark along full length of back edge of ramp plate. Slide ramp plate forward over dock leveler the width of bushing tool, approximately, 2".
8. Place bushing tool on marked line at each end of ramp to ensure proper alignment at both ends. A Skil Roto Hammer #736 or similar tool is recommended.
9. Using the back edge of the ramp plate as a guide, groove concrete approximately 3/4" deep by 2" wide, and should be the entire length of ramp plate.
10. Slide ramp plate back into position with the top of the ramp plate flush with the top of the base plate. Tack weld each end and center of ramp plate to base plate.
11. Using ramp plate as a guide drill (9) 5/8" dia. by 5" deep holes. Install anchor bolts per manufacturers specifications, and tighten securely. Weld anchor bolt nuts to ramp plate using a 1/4" fillet weld all the way around the nut. Cut off any portion of the anchor bolt exposed through the nut, and plug weld around the top of the nut to the anchor bolt. Ensure the top of the nuts are well rounded for smooth rollover.
12. Complete bumper install:
 - a. Apply continuous weld across top of each bumper. Skip welding is acceptable to prevent warpage, but complete weld must be completed.
 - b. Plug weld mounting holes to imbed.
13. Finish welding the base plate:
 - a. Weld the top of end base plate and first hinge to imbed.
 - b. Weld top of each hinge tube to imbed
 - c. Weld vertically along each end of base plate
 - d. Fully plug weld all holes in base plate.
14. Installer must remove all welding slag, and repaint welded areas.
15. Installer must adjust springs on all mechanical Edge of Dock levelers to provide desired tension for smooth operation. See page 30.

Ramp Mount - Weld On w/Formed Angle (continued)

! WARNING

Securely block or support ramp and lip when in vertical positions. Lack of proper bracing can result in ramp dropping during adjustment or installation.

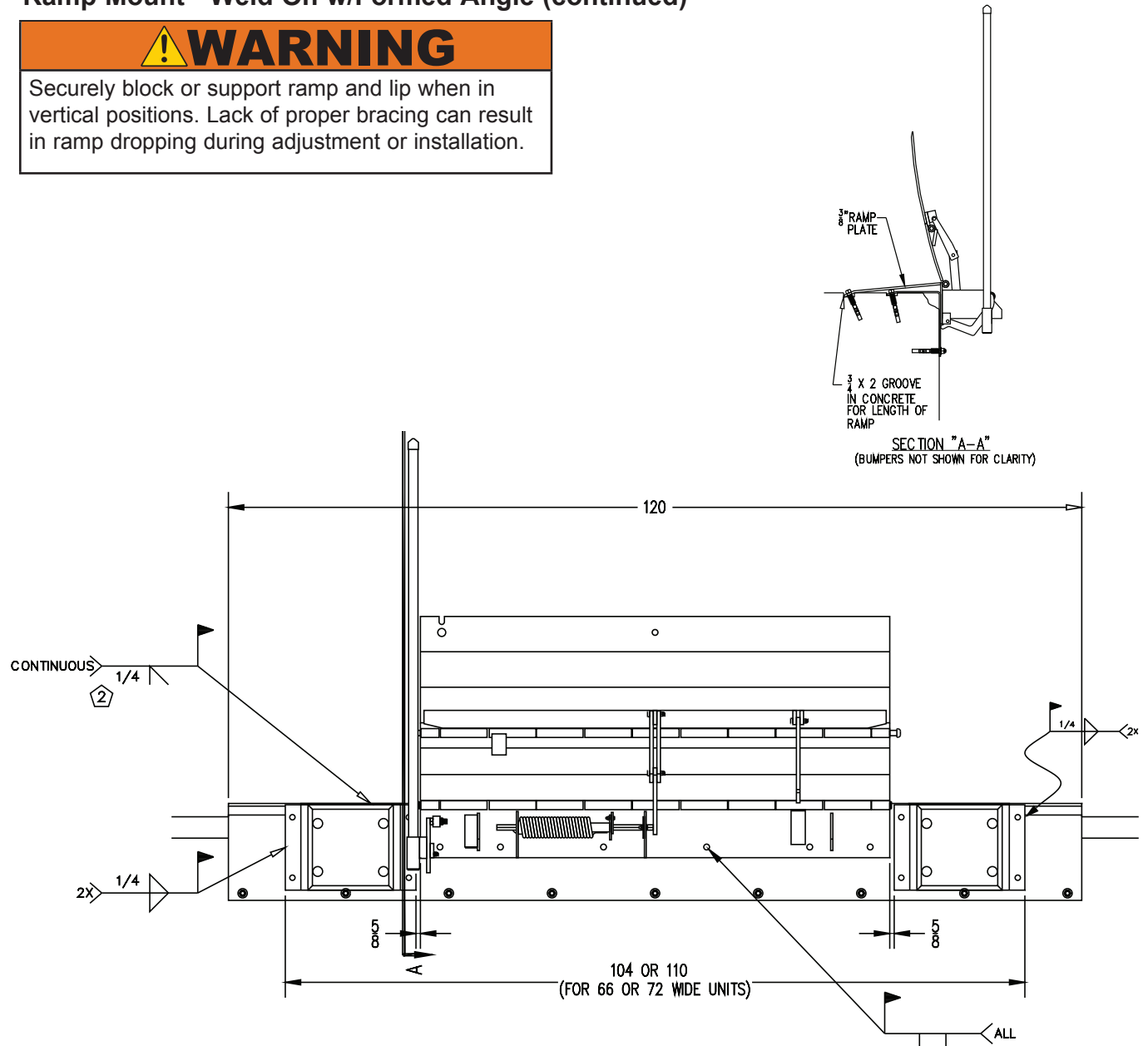

Figure 9

Note:

1. Top of base plate and bumper cover plate to be flush with top of ramp plate.
2. Apply continuous bevel weld across both bumpers and length of base plate.
3. To figure ramp plate length, need 12" ramp for every 1-1/2" of rise to ramp.
4. To install formed angle, see formed angle installation instructions on page 21.

INSTALLATION

Formed Angle

A formed angle is used when there is no existing dock steel and concrete at the dock edge has been damaged. The formed angle is required to rebuild the damaged concrete edge for a proper installation if the dock height is adequate.

1. Remove all existing bumper material and protruding objects from dock edge. Clean and sweep dock edge free of debris and flammable chemicals before installing unit.
2. At chosen location for the formed angle, locate the center of space and mark a point half of the angle width to the left and right.
3. Using a proper lifting device, raise and position the formed angle to marked position, slide formed angle against dock face.
4. Mark along full length of back edge of formed angle. Slide angle forward the width of brushing tool, approximately 2".
5. Place brushing tool on marked line at each end of formed angle to ensure proper alignment at both ends. A Skil Roto Hammer #736 or similar tool is recommended.
6. Using the back edge of the formed angle as a guide, groove concrete approximately 5/8" deep by 2" wide, and should be the entire length of the formed angle.
7. Slide formed angle back until tight against dock face. drill 5/8" dia. by 5" deep holes through formed angle at back edge. Install anchor bolts per manufacturers specifications, and tighten securely. Weld anchor bolt nuts to formed angle using a 1/4" fillet weld all the way around the nut. Cut off any portion of the anchor bolt exposed through the nut, and plug weld around the top of the nut to the anchor bolt. Ensure the top of the nuts are well rounded for smooth rollover.
8. Drill 5/8" dia. by 5" deep holes in dock face through holes in formed angle. Install anchor bolts with washers and tighten securely per manufacturers specifications.

Formed Angle (continued)

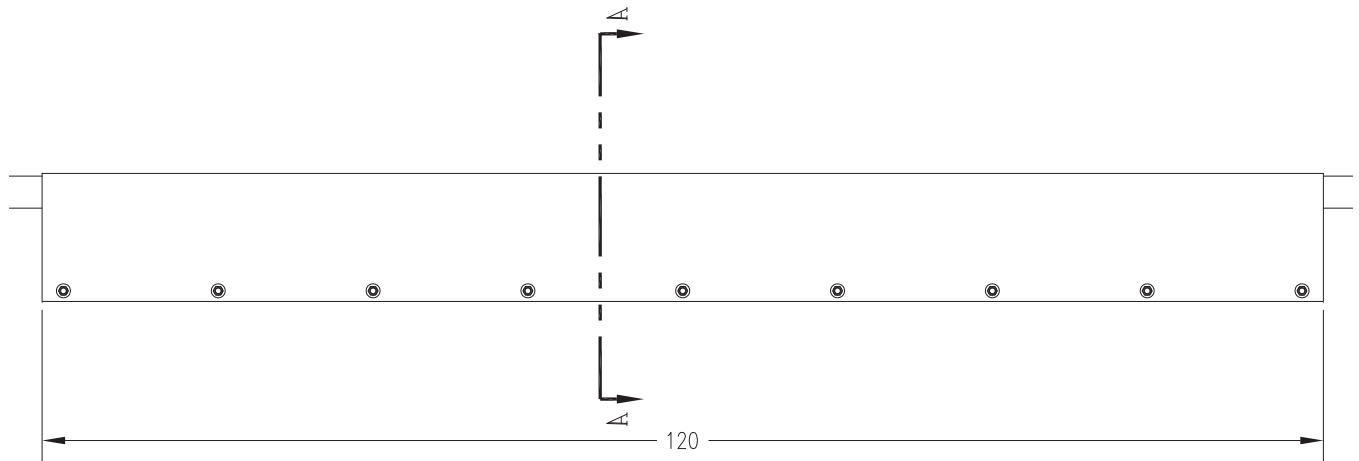
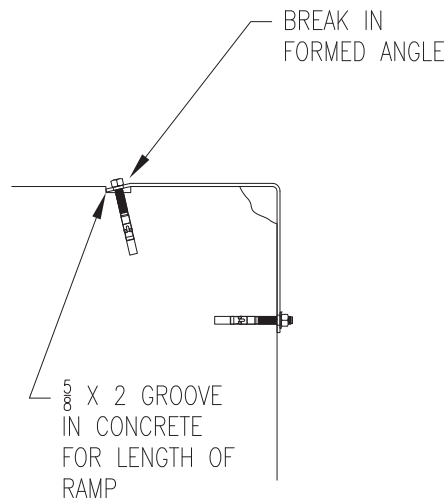

Figure 10

Note:

1. Secure formed angle with (18) anchor bolts, (9) each side.

INSTALLATION

Ramp and Face Plate

A ramp mount requiring a face plate application is used when there is no existing dock steel and the concrete at the dock edge has been damaged. The dock height can be low, high, or adequate for this application, however, the face plate and ramp plate are required to rebuild the damaged concrete edge.

1. Remove all existing bumper material and protruding objects from dock edge. Clean and sweep dock edge free of debris and flammable chemicals before installing unit.
2. At chosen location for the face plate, locate the center of space and mark a point half of the face plate width to the left and right.
3. Using a proper lifting device, raise and position the face plate to marked position, and push face plate against dock face.
4. Top of face plate should be flush with the top of dock floor. Mark center of holes in face plate into dock face. Drill 5/8" dia. by 5" holes into dock face. Install anchor bolts with washers per manufacturers specifications and tighten securely.
5. Place ramp plate to match each end of the face plate. Leading (forward) edge of ramp plate should be flush with dock face.
6. Mark along full length of back edge of ramp plate. Slide ramp forward the width of bushing tool, approximately 2".
7. Place bushing tool on marked line at each end of ramp to ensure proper alignment at both ends. A Skil Roto Hammer #736 or similar tool is recommended.
8. Tack weld ramp to face plate on each end to secure in place.
9. Using the back edge of the ramp plate as a guide, groove concrete approximately 5/8" deep by 2" wide, and should be the entire length of the ramp plate.
10. Break tack welds and slide ramp back until forward edge is flush with dock face. Tack weld ramp on each end and center to face plate. Drill 5/8" dia. by 5" deep holes through ramp plate at back edge. Install anchor bolts per manufacturers specifications, and tighten securely. Weld anchor bolt nuts to ramp plate using a 1/4" fillet weld all the way around the nut. Cut off any portion of the anchor bolt exposed through the nut, and plug weld around the top of the nut to the anchor bolt. Ensure the top of the nuts are well rounded for smooth rollover.
11. Apply a continuous fillet weld at the created joint between the face plate and ramp. Skip welding should be the proper method used to avoid warping.

Ramp and Face Plate (continued)

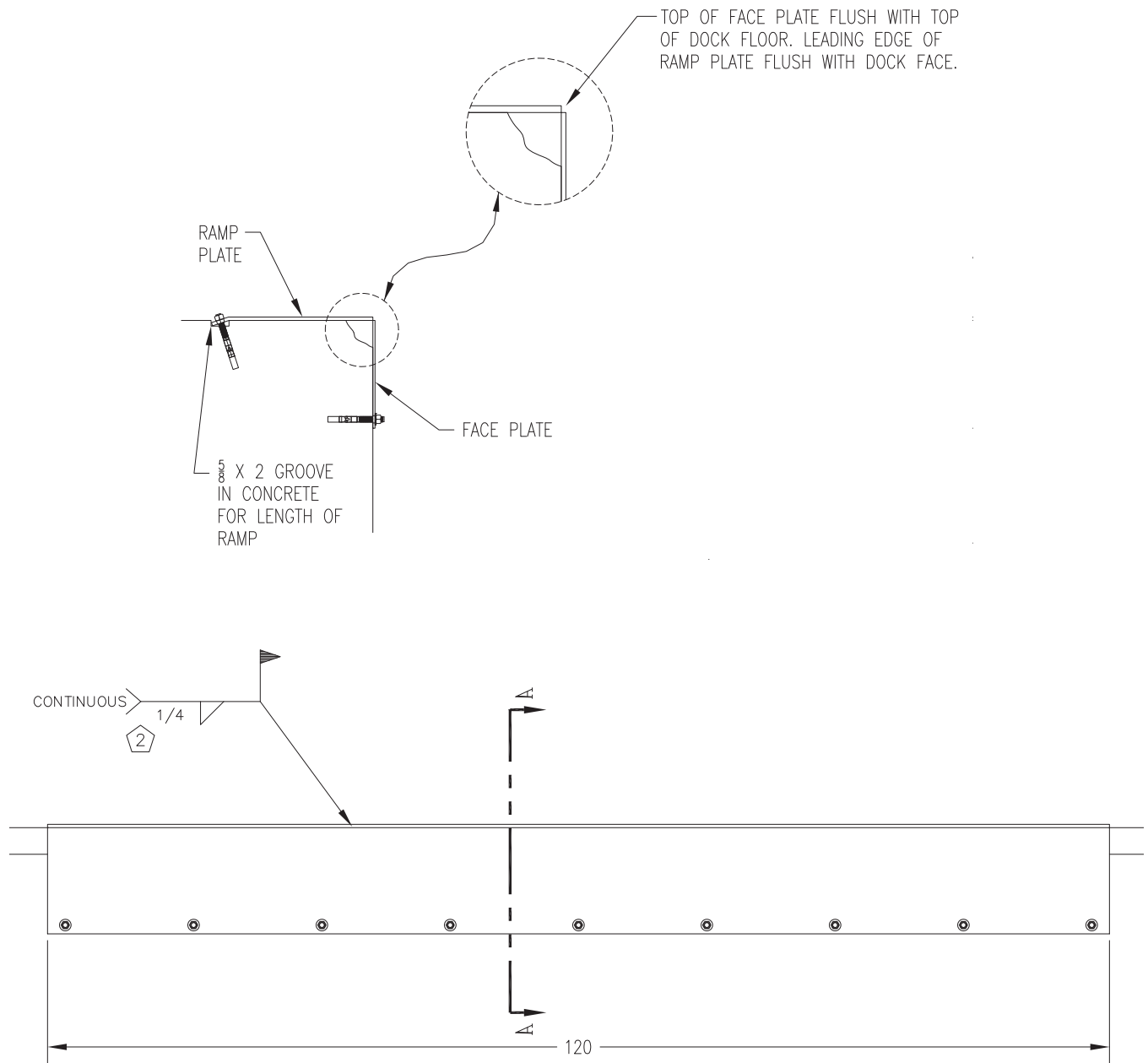

Figure 11

Note:

1. Secure formed angle with (18) anchor bolts, (9) each side.
2. Apply continuous fillet weld across entire length of face plate and ramp.

INSTALLATION

Placard Installation Instructions

- Owner/Users are responsible for the installation and placement of product placards.
- Make sure placard is in plain view of dock leveler and/or vehicle restraint operations.
- Suggested placement of placard is near control box attached to electrical conduit by using nylon cable tie. If there is no control box present, mount placard on wall to the immediate left of leveler at eye level.

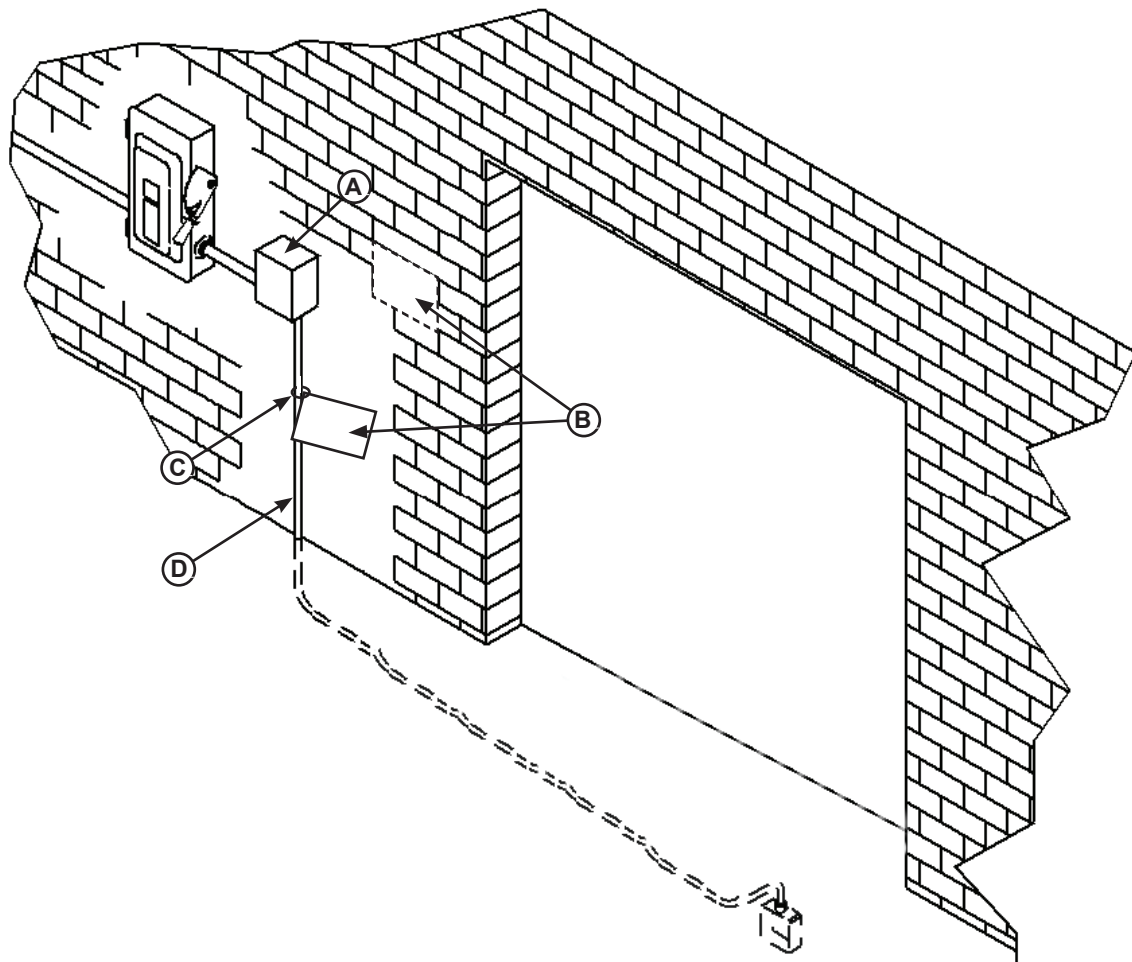

A - Control Box

B - Placard

C - Nylon Cable Tie

D - Conduit

Figure 12

Operational Precautions

DANGER

Stay clear of dock leveler and vehicle restraint when transport vehicle is entering or leaving dock area.

DO NOT move or use the dock leveler or restraint if anyone is under or in front of leveler.

Keep hands and feet clear of pinch points. Avoid putting any part of your body near moving parts.

WARNING

Only trained personnel should operate the dock leveler.

DO NOT use a broken or damaged dock leveler. Make sure proper service and maintenance procedures have been performed on leveler before using.

Transport vehicle wheels must be chocked unless a vehicle restraint is used. Never remove the wheel chocks until loading/unloading is finished and transport driver has been given permission to leave.

Make sure platform lip rests on the transport vehicles bed with at least 4 in. (102 mm) of overlap.

Maintain a safe distance from side edges of leveler during the loading/unloading process.

WARNING

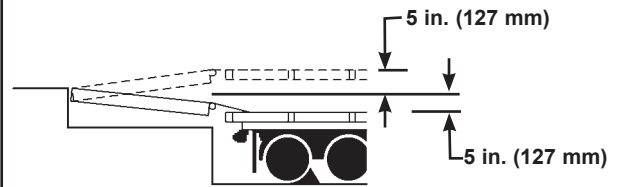

The MEDLF mechanical dock leveler is designed to compensate for a maximum ± 5 in.* (127 mm) of height difference between the loading dock and the transport vehicles bed. DO NOT use the dock leveler if the transport vehicles bed is more than 5 in. (127 mm) higher or lower than the dock floor.

*Service height may vary with design specifications

DO NOT overload the dock leveler.

DO NOT operate any equipment while under the influence of alcohol or drugs.

DO NOT leave equipment or material unattended on the dock leveler.

OPERATION

Operating Instructions



Figure 13

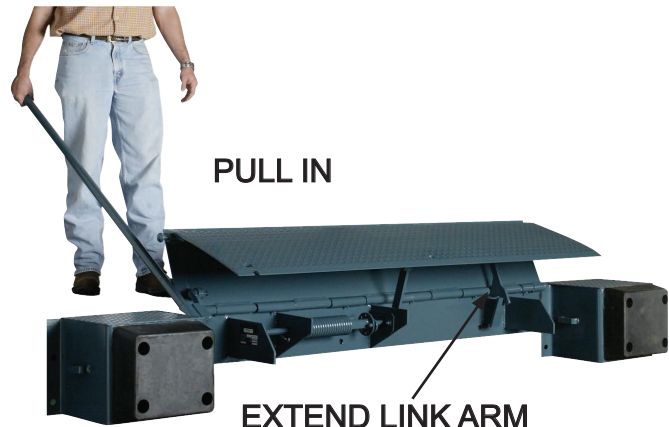

Figure 14

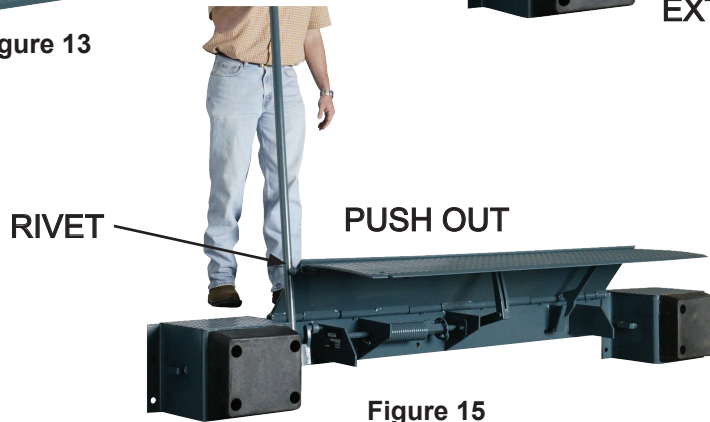

Figure 15

1. Before activating dock leveler, ensure lip avoids contact with transport vehicle sides and cargo. If lip does not lower to transport vehicle bed, reposition transport vehicle.
 2. Instruct driver to remain at the dock until the loading or unloading process has been completed.
 3. Chock the transport vehicle wheels, or use a vehicle restraint if available.
 4. If necessary, remove any end loads with the leveler in the stored position.
 5. Extend the dock leveler onto the transport vehicle as follows:
 - a. Grasp the captured operating handle. See Figure 13.
 - b. Pull handle toward you, rotating center plate back past vertical. Lip plate extend link arm will engage at this time. See Figure 14.
 - c. Push forward on operating handle against the rivet, rotating leveler out onto transport vehicle bed. See Figure 15.
 - d. Return handle to stored position.
 6. Proceed with loading or unloading.
 7. When loading or unloading is finished, remove leveler from transport vehicle:
 - a. Grasp the captured operating handle. See Figure 13.
 - b. Pull handle toward you, rotating center plate back until lip clears transport vehicle bed.
 - d. Return handle and leveler to stored position.
 8. Remove chocks from transport vehicle wheels, or release the vehicle restraint if used.
 9. Indicate to driver that the transport vehicle may leave the dock.
- Note:** Leveler will automatically return to the stored position if not stored manually as instructed in step 7..

This page intentionally left blank.

MAINTENANCE

Maintenance Precautions

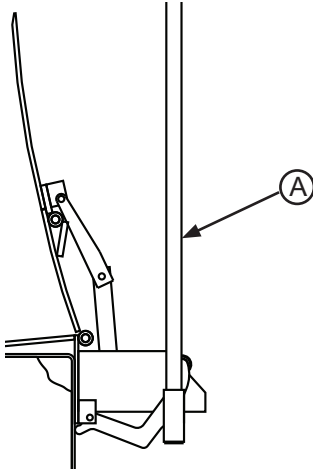

Figure 16

A— Handle

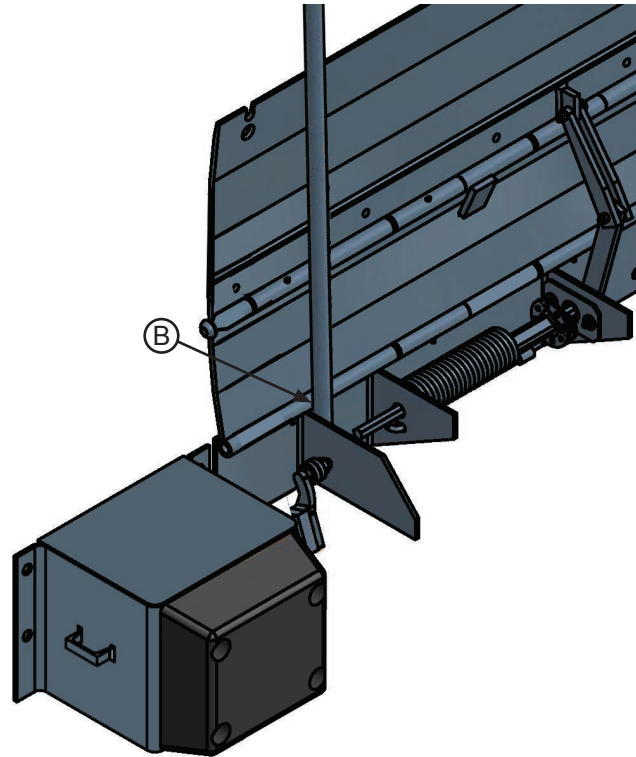

Figure 17

B —Maintenance Prop Receiver

DANGER

It is recommended and good safety practice to use an additional means to support the dock platform and lip anytime when physically working in front of or under the dock leveler. This additional means may include, but is not limited to a boom truck, fork truck, stabilizing bar or equivalent.

WARNING



Always post safety warnings and barricade the work area at dock level and ground level to prevent unauthorized use of the unit before maintenance is complete.

When maintenance is to be performed in front of the dock leveler, support the lip with the handle in the maintenance prop position or by other means.

Put handle (A) into maintenance prop position (B) by pulling handle out of roller arm assembly and placing into maintenance prop receiver (B). See Figure 17.

The maintenance prop / handle supports both the lip and center plate.

WARNING

A hard hat or other applicable head protection should always be worn when working under or around a dock leveler.

Always stand clear of platform lip when working in front of the dock leveler.

Periodic Maintenance

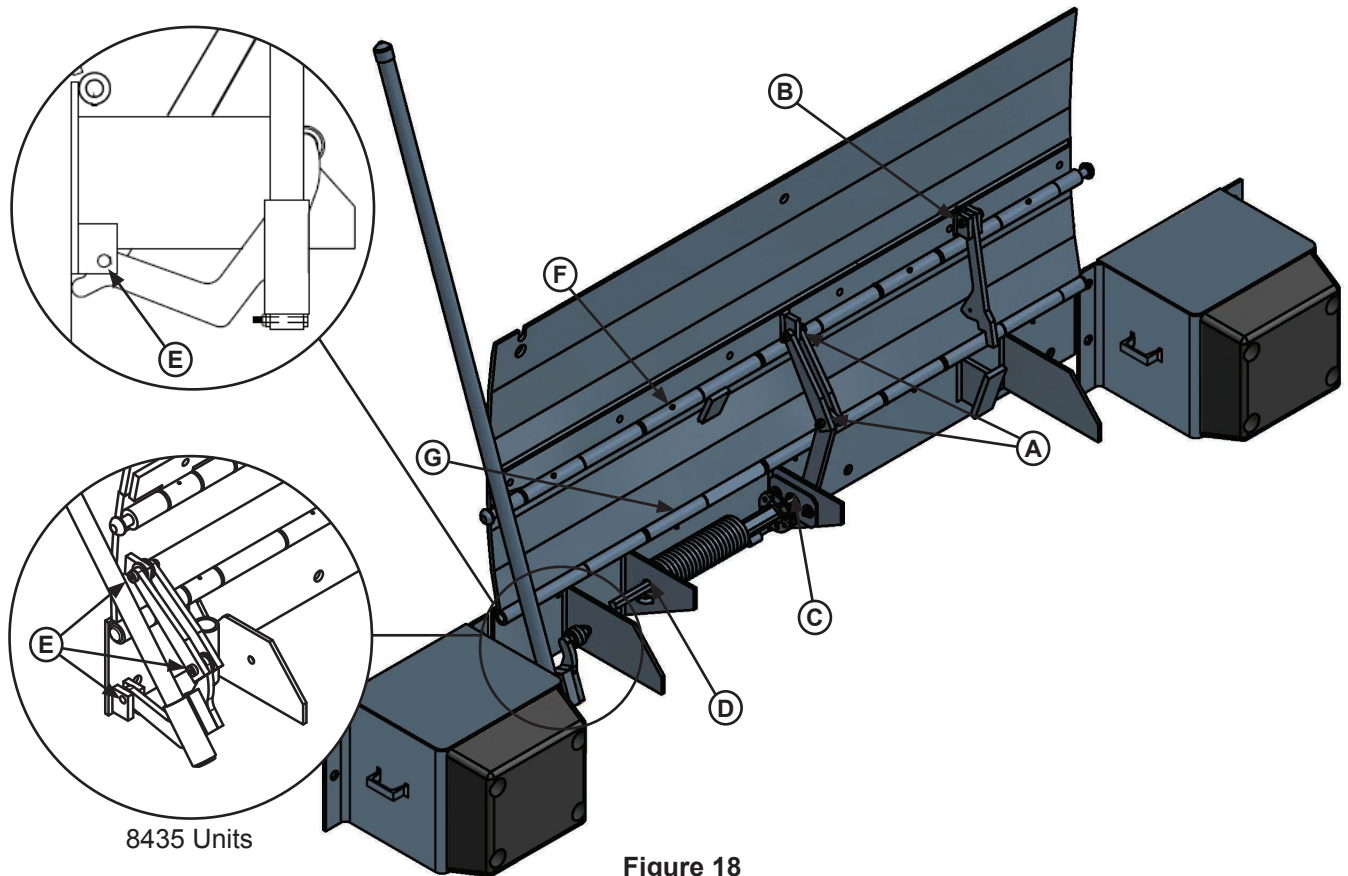

Figure 18

Weekly Maintenance

- Operate the dock leveler through the complete operating cycle to maintain lubrication.
- Inspect the platform hinge and the lip hinge areas. The hinge areas must be kept free of dirt and debris. Build-up of foreign material in the hinge areas will increase wear and cause abnormal operation.
- Inspect warning decals and placards. Replace if damaged or missing.
- Check bumpers for more than 1" of wear. Replace worn, loose, damaged or missing bumpers.

Quarterly Maintenance

- Perform Weekly Maintenance.
- Inspect welds for cracks or damage, and inspect lip and rear hinge pins. Repair or replace damaged or cracked parts as needed.

- Lubricate the following areas with light-weight machine oil:

- (A) — Linkage arm pivots
- (B) — Extend link arm pivot
- (C) — Torsion bearing
- (D) — Torsion bar pivot
- (E) — Operating linkage pivots

- Lubricate the following areas with white lithium grease:

- (F) — Lip plate grease fittings
- (G) — Base plate grease fittings

NOTICE

Failure to properly lubricate the dock leveler will cause abnormal operation of the leveler.

ADJUSTMENTS

Spring Adjustment

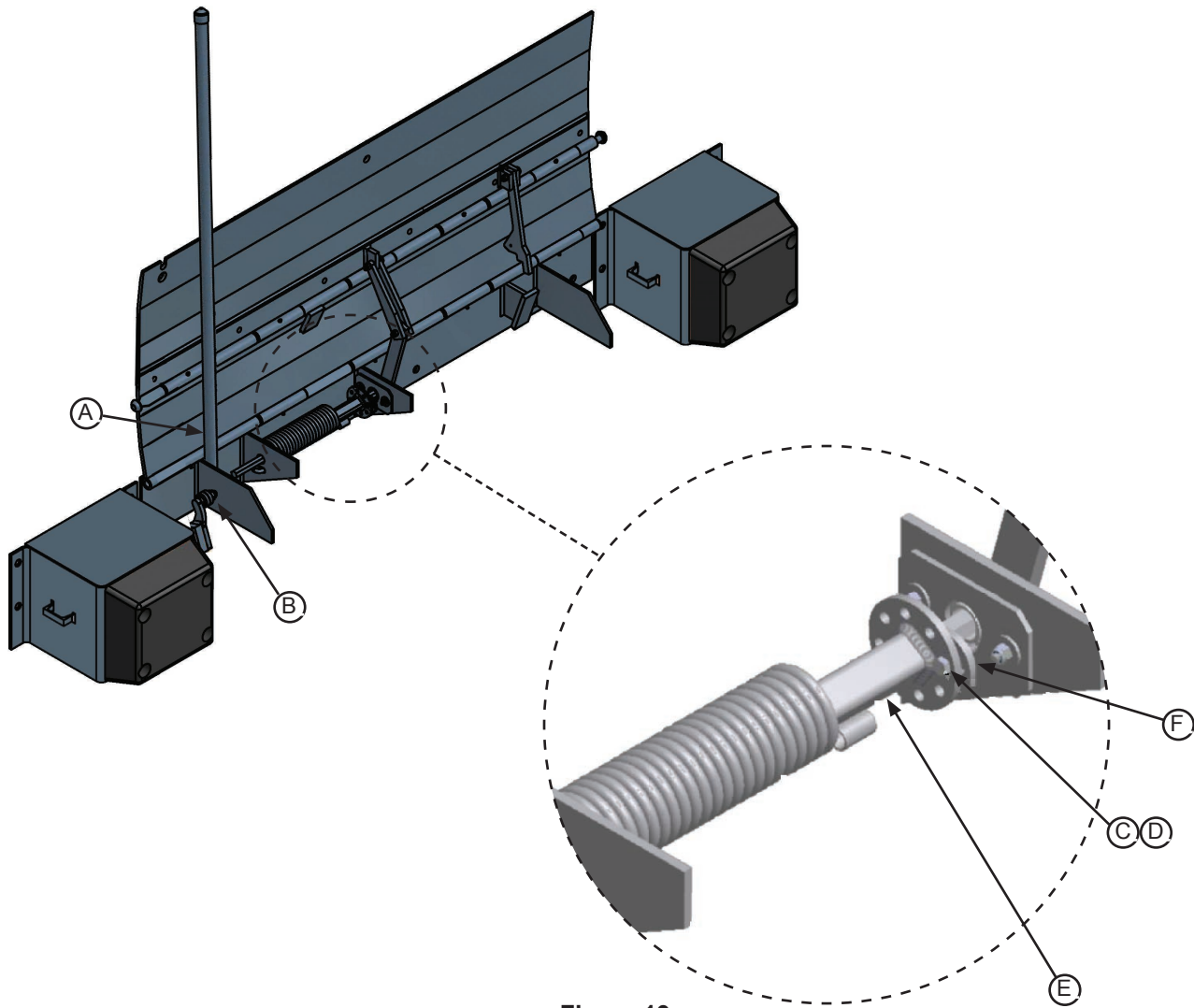



Figure 19

Torsion Spring Adjustment Instructions

1. Lift and secure leveler in full upright position and install handle (A) in maintenance prop receiver (B) as shown on page 28.
2. Remove nut (C) from hex bolt (D)
3. Place an adjustable wrench on torsion tube (E) assembly, apply enough downward force to tube assembly until hex bolt (D) can be removed from the locking plate (F).
4. Rotate torsion tube (E) with downward force until flange on the tube assembly lines up with the next hole in the locking plate (F).
5. Insert hex bolt (D) and install nut (C) and tighten.
6. Store maintenance handle (A) lower leveler to stored position.
7. Test leveler operation. If spring tension is not sufficient, repeat the previous steps 1-6 until desired tension is achieved.

TROUBLESHOOTING

 DANGER

It is recommended and good safety practice to use an additional means to support the dock platform and lip anytime when physically working in front of or under the dock leveler. This additional means may include, but is not limited to a boom truck, fork truck, stabilizing bar or equivalent.

 WARNING

Always post safety warnings and barricade the work area at dock level and ground level to prevent unauthorized use of the dock leveler before maintenance is complete.

A hard hat or other applicable head protection should always be worn when working under or around a dock leveler.

Always stand clear of platform lip when working in front of the dock leveler.

 WARNING

The maintenance prop **MUST** be in the service position when working under the dock leveler. For maximum protection, use an OSHA approved locking device to lock the maintenance prop in the service position. Only the person servicing the equipment should have the key to unlock the maintenance prop.

Symptom	Possible Cause	Solution
Unit does not operate properly, or is very difficult to operate.	Debris impacted in the hinge line.	Clean out debris.
	Insufficient lubrication.	Lubricate leveler; see pages 29-31.
	Main springs need more tension or less tension.	Adjust main springs; see page 30.
	Damaged or missing parts.	Repair or replace as needed.
Extend link arm does not latch out lip or unlatch.	Worn or damaged linkage.	Replace worn or damaged parts.
	Extend link arm needs lubrication.	Lubricate extend link arm.

If additional troubleshooting assistance is required, contact Systems, LLC Technical Services with equipment serial number or customer order number (CO#).

Technical Service at 800-643-5424 or techservices@loadingdocksystems.com

PARTS

MEDLF-Series

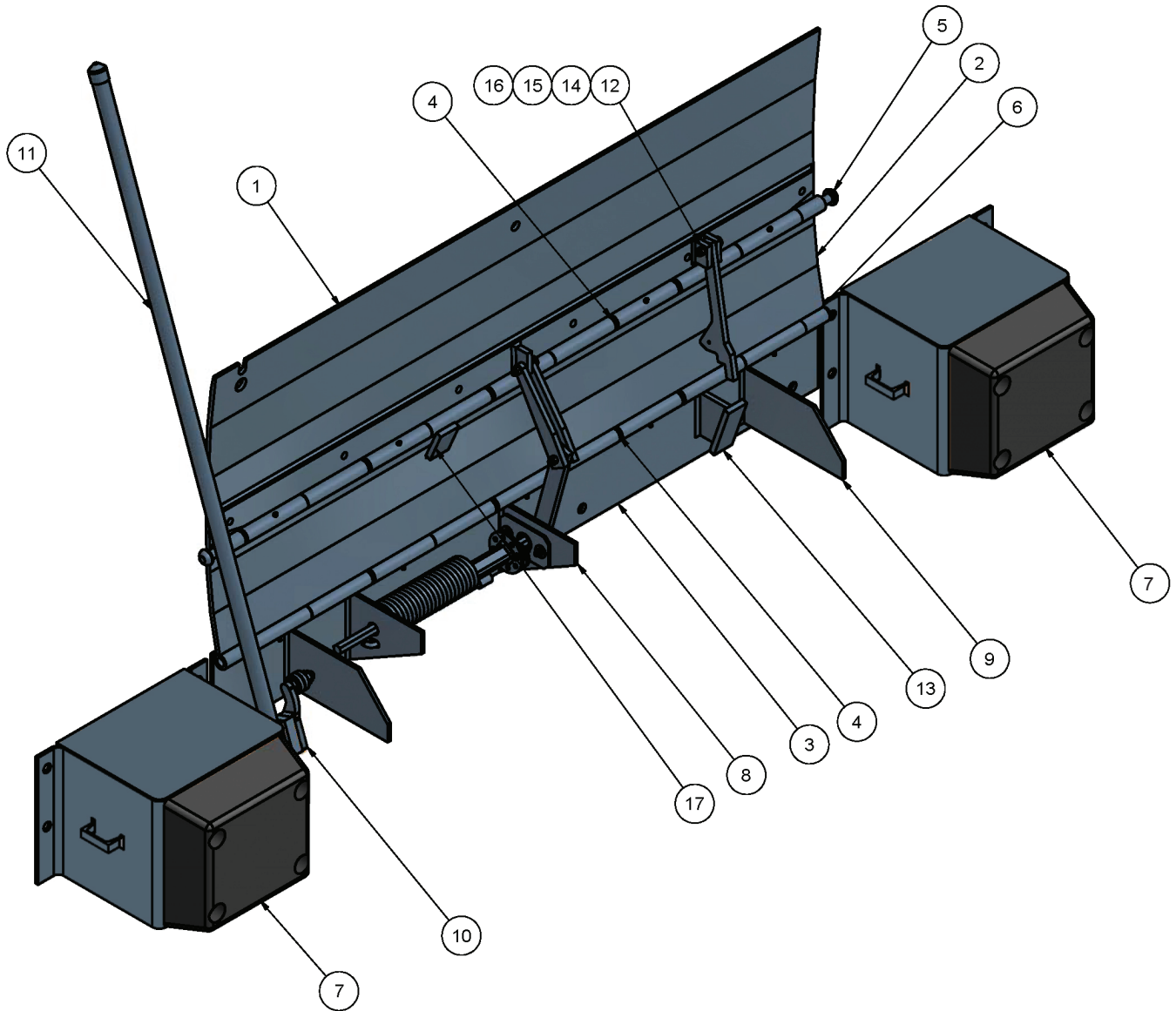

PARTS

ITEM	QTY	SIZE/CAPACITY	DESCRIPTION	PART NUMBER (15" LIP)	PART NUMBER (17" LIP)
1	1	6620/25	Lip Plate & Hinge Assembly	7303-0039	7303-0040
		6630	Lip Plate & Hinge Assembly	7303-0041	7303-0042
		6635	Lip Plate & Hinge Assembly	7303-0043	7303-0044
		7220/25	Lip Plate & Hinge Assembly	7303-0045	7303-0046
		7230	Lip Plate & Hinge Assembly	7303-0047	7303-0048
		7235	Lip Plate & Hinge Assembly	7303-0049	7303-0050
		7820/25	Lip Plate & Hinge Assembly	7303-0051	7303-0052
		7830	Lip Plate & Hinge Assembly	7303-0053	7303-0054
		7835	Lip Plate & Hinge Assembly	7303-0055	7303-0056
		8420/25	Lip Plate & Hinge Assembly	7303-0057	7303-0058
		8430	Lip Plate & Hinge Assembly	7303-0059	7303-0060
		8435	Lip Plate & Hinge Assembly	7303-0061	7303-0062
2	1	6620/25	Center Plate & Hinge Assembly		
		6630	Center Plate & Hinge Assembly	7303-0105	
		6635	Center Plate & Hinge Assembly	7303-0106	
		7220/25	Center Plate & Hinge Assembly	7303-0107	
		7230	Center Plate & Hinge Assembly	7303-0108	
		7235	Center Plate & Hinge Assembly	7303-0109	
		7820/25	Center Plate & Hinge Assembly	7303-0110	
		7830	Center Plate & Hinge Assembly	7303-0111	
		8420/25	Center Plate & Hinge Assembly	7303-0113	
3	1	ALL	Base Plate & Hinge Assembly	Consult Factory	
4	2	6620/25/30	Hinge Pin	DOTH-3104	
		6635	Hinge Pin	DOTH-4312	
		7220/25/30	Hinge Pin	DOTH-3122	
		7235	Hinge Pin	DOTH-4313	
		7820/25/30	Hinge Pin	DOTH-3946	
		8420/25/30	Hinge Pin	DOTH-3920	
5	2	All	Rivet - Button	DOTH-2400	
6	2	All	Rivet - Flat	DOTH-2398	
7	1	All	Bumper Block	DBBS-3519	
8	2	All	HL Linkage Adder Assembly	DOTH-3675	
9	2	All	X-Gusset	DOTH-3589	
		All Except 35K	NLIII Operating Link Assembly	DOTH-3696	
		35K Up To 78" Wide	NLIII Operating Link Assembly	DOTH-3697	
11	1	All	NLIII Handle Assembly 60"	DOTH-3694	
12	1	All	Extend Link Arm	DOTH-3585	
13	1	All	Extend Link Arm Stop	DOTH-3586	
14	2	All	Pivot Block	DOTH-3316	
15	1	All	Shoulder Bolt	DOTH-2061	
16	1	All	Locknut	DOTH-2137	
17	1	All	Lip Stop	DOTH-3734	

PARTS

Torsion Spring Assembly

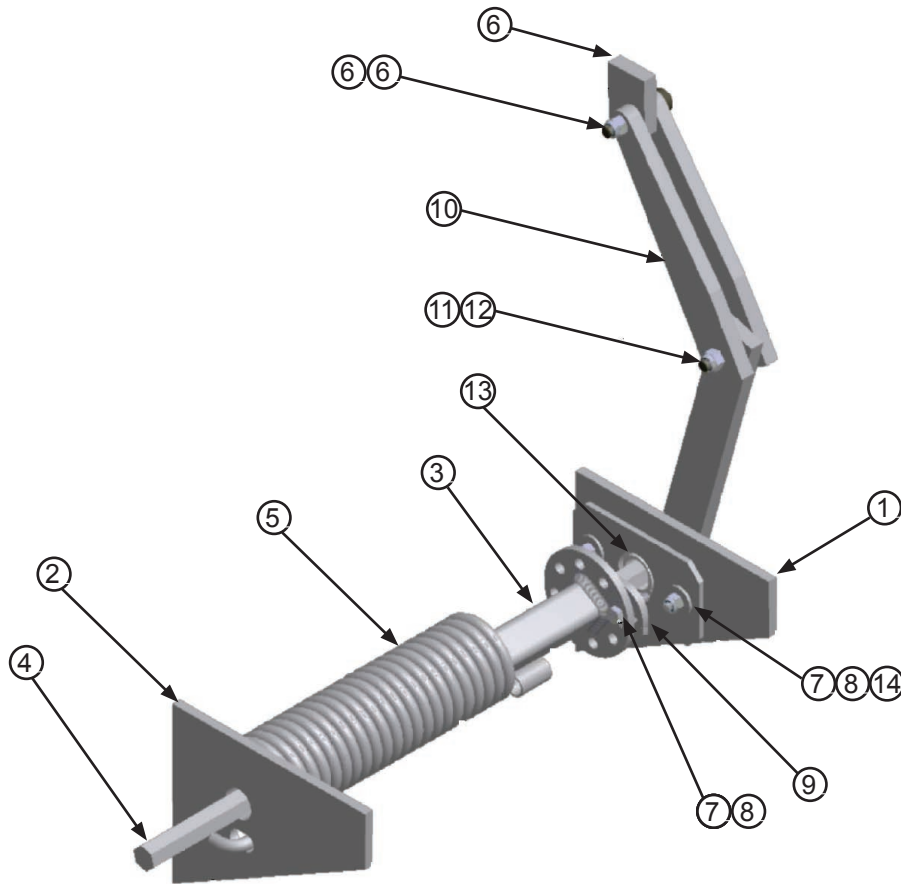

Item	Quantity	Part Number	Description
*	*	DOTH-3675	Torsion Spring Kit (Hex Linkage Adder) Includes 1-14
1	1	DOTH-3303	L&R Gusset Assembly W/Whole
2	1	DOTH-3327	HL Model Gusset w/Guide
3	1	DOTH-3679	HL Torsion Tube Assembly
4	1	DOTH-3676	HL Torsion Bar Assembly
5	1	DOTH-2509	Spring Torsion
6	1	DOTH-3316	Bar-Pivot
7	3	DOTH-2033	HHCS - Grade 2 - Zinc Plated
8	3	DOTH-2121	Nylon Lock Nut
9	1	DOTH-3682	HL Plate Locking Torsion
10	2	DOTH-3617	Bar - 6630 L-Linkage
11	2	DOTH-2061	1-1/2" Shoulder Bolt
12	2	DOTH-2137	Locknut
13	1	DOTH-2406	Bearing
14	2	DOTH-2206	Washer 5/16

Operating Links

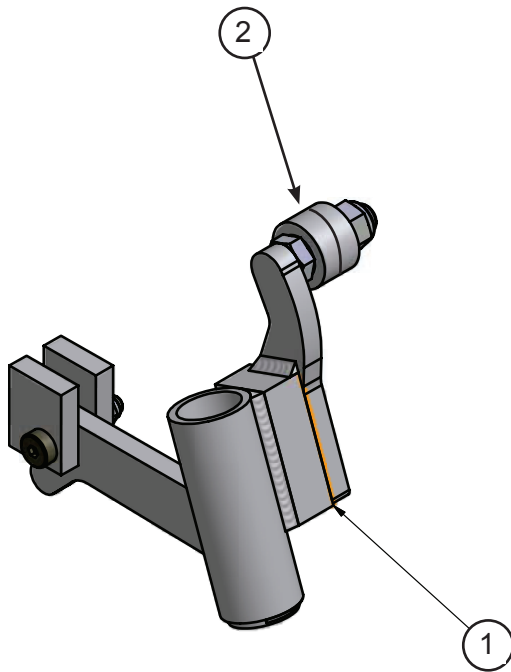

Item	Quantity	Part Number	Description
1	1	DOTH-3696	NLIII Operating Link Assembly (closed bottom)
		DOTH-3697	NLIII Operating Link Assembly (closed bottom, 35K units up to 78" wide)
2	2	DOTH-2449	Roller Bearing (Included in 1)

PARTS

NLIII Operating Link (8435)

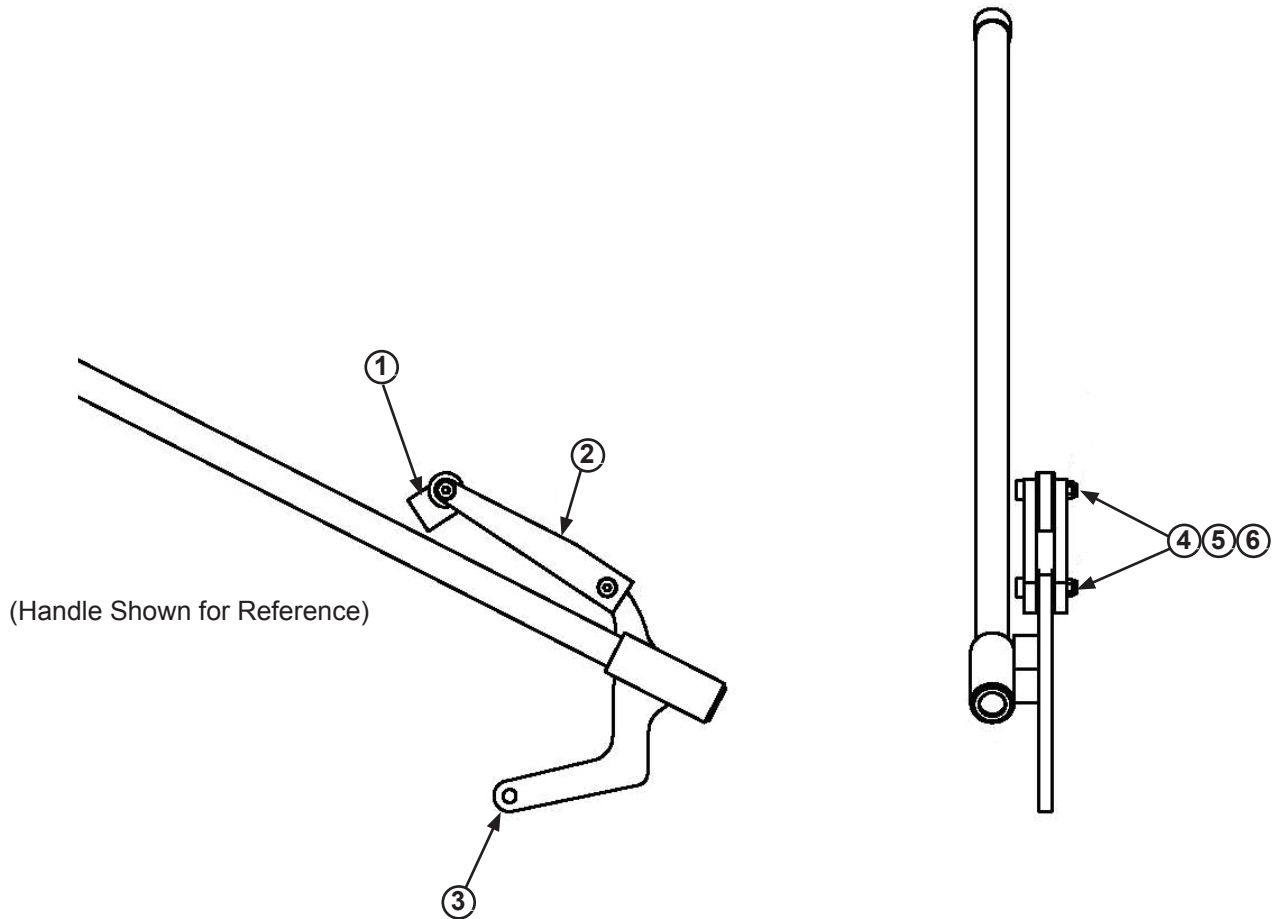

Item	Quantity	Part Number	Description
*	*	DOTH-3871	NLIII Operating Linkage (35K 84" wide units)
1	1	DOTH-3316	Pivot, Base Plate
2	2	DOTH-3317	Bar, Base Plate
3	1	DOTH-3870	NL Operating Link Arm, 35 K
4	2	DOTH-2061	Shoulder Bolt 3/8"-16 UNC 1-1/2" lg
5	2	DOTH-2137	Nut,Lock 3/8"-16
6	4	DOTH-2210	Washer, Flat 1/2"

This page intentionally left blank.

PARTS

Bumpers - 4" x 12" x 13"

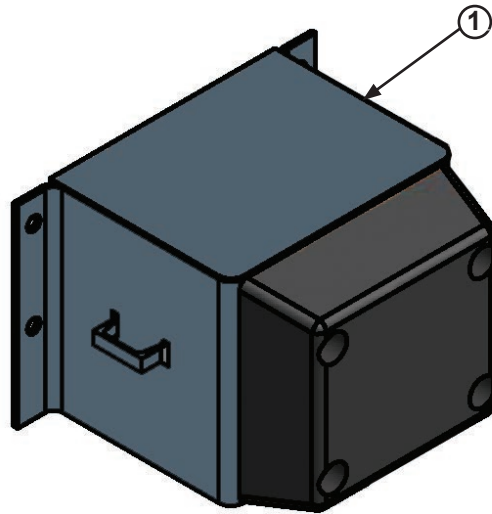

Item	Quantity	Part Number	Description
*	*	DBBS-3519	4" x 12" x 13" Bumper Block Assembly, Complete
1	1	DOTH-3544	12" Bumper Block Weldment

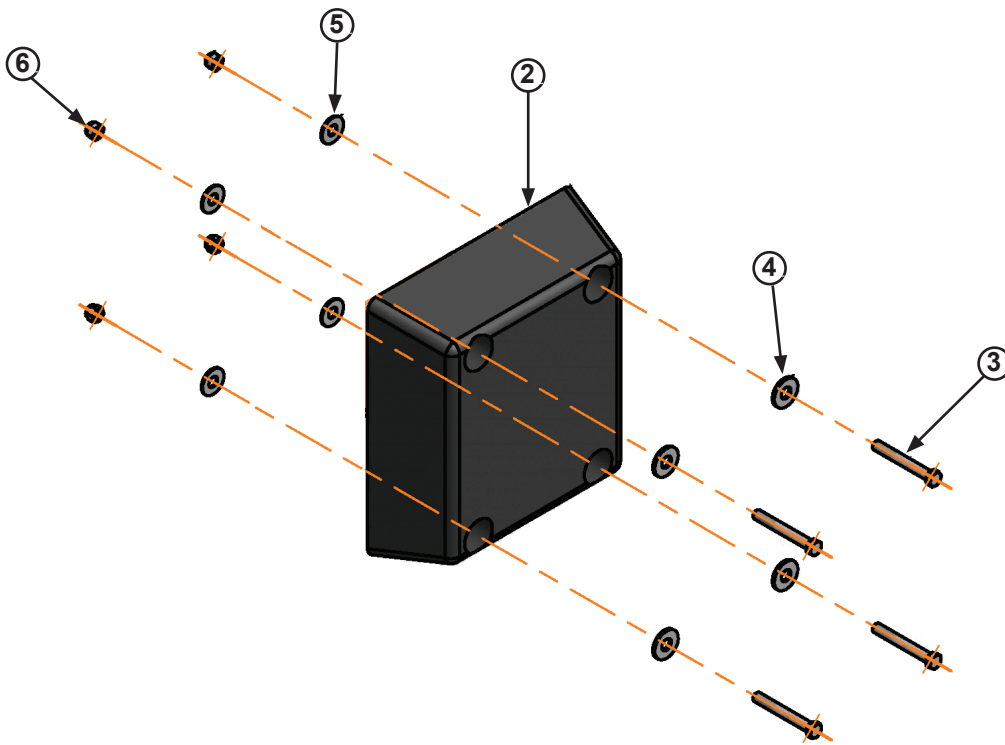

Item	Quantity	Part Number	Description
*	*	DKIT-3540	Rubber Bumper and Hardware Kit
2	1	DOTH-3505	Molded Rubber Bumper 4" x 12" x 13"
3	4	DOTH-2056	Hex Head Cap Screw
4	4	DOTH-2208	Washer - Flat - Zinc Plated
5	4	DOTH-2259	Washer - Spilt Lock
6	4	DOTH-2140	Nut - Nylon Lock

Bumpers - 4" x 10" x 18" (optional)

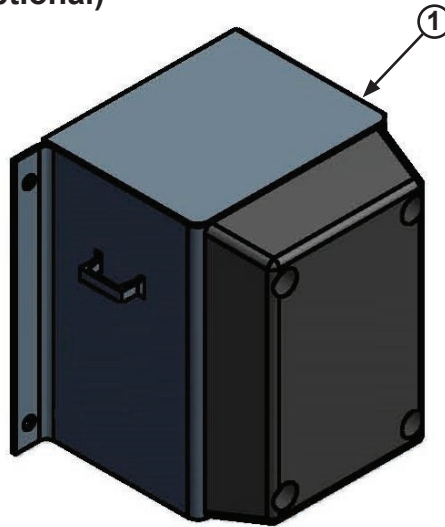

Item	Quantity	Part Number	Description
*	*	DBBS-3549	4" x 10" x 18" Bumper Block Assembly, Complete
1	1	DOTH-3844	18" Bumper Block Weldment

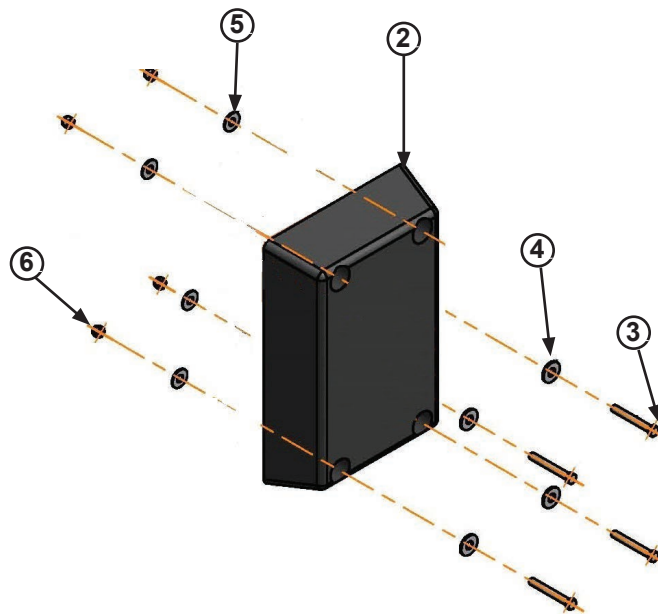

Item	Quantity	Part Number	Description
*	*	DKIT-3541	Rubber Bumper and Hardware Kit
2	1	DOTH-3559	Molded Rubber Bumper 4" x 10" x 18"
3	4	DOTH-2056	Hex Head Cap Screw
4	4	DOTH-2208	Washer - Flat - Zinc Plated
5	4	DOTH-2259	Washer - Spilt Lock
6	4	DOTH-2140	Nut - Nylon Lock

PARTS

Bumpers - 12" Sliding (optional)

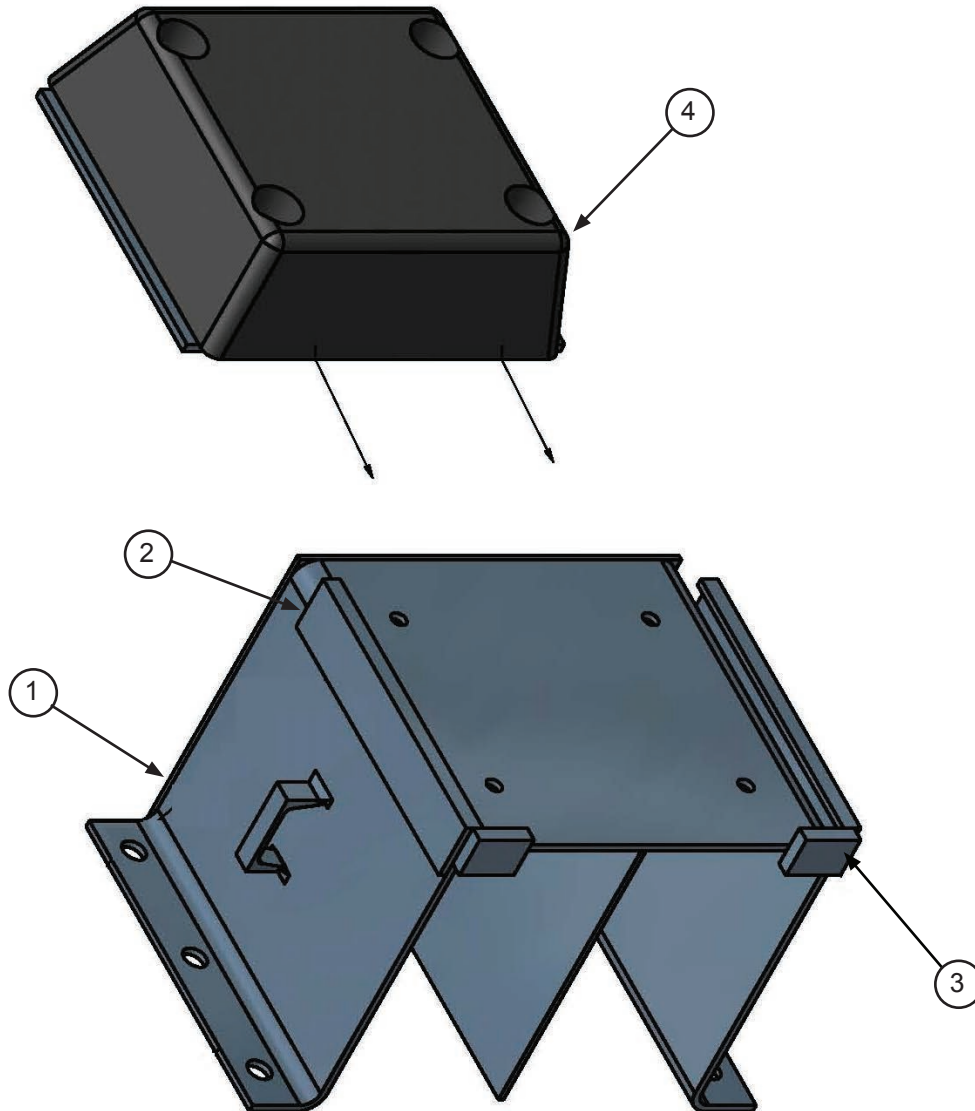

Item	Quantity	Part Number	Description
*	*	DBBS-3543	12" Sliding Bumper Block Assembly, Complete
1	1	DOTH-3544	12" BB Weldment
2	2	DOTH-3514	Angle - 12" BB Slide
3	2	DOTH-3515	Bar - BB Sliding Stop
4	1	DOTH-3517	12" Sliding BB Plate w/Rubber

Customer Information

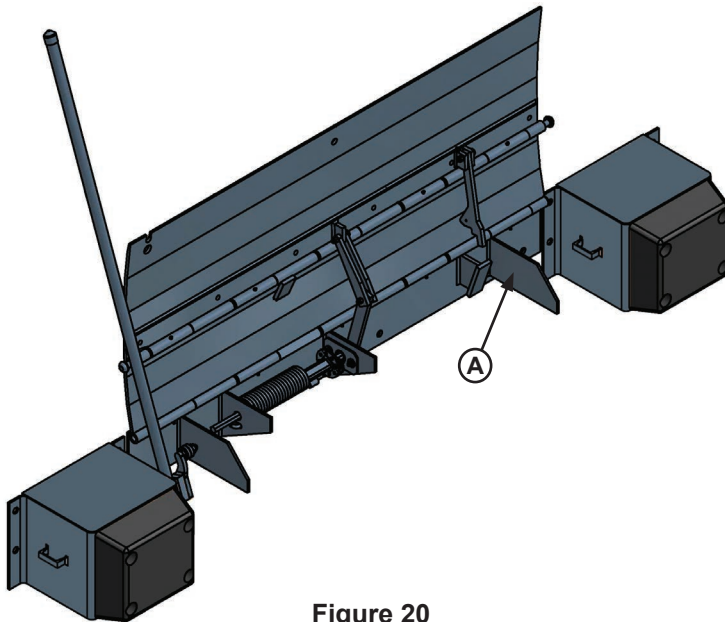

Figure 20

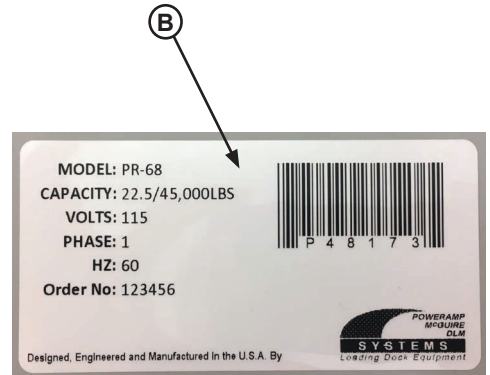

Figure 21

NOTE: Refer to Figure 20 for orientation of dock leveler and Figure 21 for example of decal.

The LEVELER model/serial number decal is located on the left platform joist near the front (lip) of dock leveler (A).

When you receive your new equipment, write down the model and serial number in the form provided. This will help ensure safe keeping of the numbers in the event the model/serial number decal (A, B) becomes lost or damaged.

Also, write down Systems, LLC's order number, the company that installed the dock leveler, and the original owner's name. This will all help to identify the specific dock leveler if more information is required.

When ordering, use part numbers and description to help identify the item ordered. Do not use "item" numbers. These are only for locating the position of the parts. Always give dock leveler MODEL NUMBER and/or SERIAL NUMBER.

For service, call or contact:

Systems, LLC
P.O. Box 309
Germantown, WI 53022

Phone: (800) 643-5424
Fax: (262) 255-5917

www.loadingdocksystems.com

Dock Leveler Information

Model _____

Serial No. _____

Systems, LLC, Job No. _____

Vehicle Restraint Information

Model _____

Serial No. _____

Systems, LLC Order No. _____

Original Owner Information

Name _____

Address _____

Installer Information

Name _____

Address _____

Date of Installation _____

STANDARD PRODUCT WARRANTY

SYSTEMS, LLC warrants that its products will be free from defects in design, materials and workmanship for a period of one (1) year from the date of shipment. All claims for breach of this warranty must be made within 30 days after the defect is or can with reasonable care, be detected. In no event shall any claim be made more than 30 days after this warranty has expired. In order to be entitled to the benefits of this warranty, the product must have been properly installed, maintained and operated in accordance with all manufacturer's recommendations and/or specified design parameters and not otherwise have been subject to abuse, misuse, misapplication, acts of nature, overloading, unauthorized repair or modification, application in a corrosive environment or lack of maintenance. Periodic lubrication, adjustment and inspection in accordance with all manufacturers' recommendations are the sole responsibility of the Owner/User.

In the event of a defect, as determined by SYSTEMS LLC, covered by this warranty, SYSTEMS LLC shall remedy such defect by repairing or replacing any defective equipment or parts, bearing the cost for the parts, labor and transportation. This shall be exclusive remedy for all claims whether based on contract, negligence or strict liability.

WARRANTY LIMITATIONS

THE ABOVE WARRANTIES ARE IN LIEU OF ANY OTHER WARRANTIES, WHETHER EXPRESSED OR IMPLIED, INCLUDING BUT NOT LIMITED TO ANY IMPLIED WARRANTY OF MERCHANTABILITY OR FITNESS FOR A PARTICULAR PURPOSE. SYSTEMS LLC AND ITS SUBSIDIARIES SHALL NOT IN ANY EVENT BE LIABLE TO ANYONE, INCLUDING THIRD PARTIES, FOR INCIDENTAL, CONSEQUENTIAL OR SPECIAL DAMAGES OF ANY KIND INCLUDING BUT NOT LIMITED TO, BREACH OF WARRANTY, LOSS OF USE, LOSS OF PROFIT, INTERRUPTION OF BUSINESS OR LOSS OF GOODWILL.