



A Division of Systems, LLC

MP Series

Dock Leveler

Owner's/User's Manual



McGuire • Division of Systems, LLC • W194 N11481 McCormick Drive • Germantown, WI 53022
800.624.8473 • fax: 262.255.5917 • www.wbmcguire.com • techservices@loadingdocksystems.com

Printed in U.S.A.
© 2019 Systems, LLC - All Rights Reserved

Manual No. 4111-0019
June 2019

Table of Contents

	Page
Precautions	
Recognize Precautionary Information	1
General Operational Precautions	1
Operational Precautions	2
Safety Decals.....	4
Placard	5
Owner's/User's Responsibilities	6
Introduction	
General Information.....	8
Component Identification.....	9
Installation	
Installation Precautions	10
Prepare Pit.....	12
Prepare Dock Leveler	13
Install Dock Leveler	14
Placard Installation Instructions	20
Operation	
Operational Precautions	21
Operating Instructions	22
Maintenance	
Maintenance Precautions.....	24
Periodic Maintenance	25
Adjustments	
Adjust Main Spring & Lip Assist Spring Tension.....	26
Adjust Lip Stop Bolt	28
Troubleshooting	
Troubleshooting.....	30
Parts	
Hold-Down Components	32
Main Lift Springs.....	33
Frame Components	34
Platform Components	36
Weather Seals.....	38
Toe Guards	39
Miscellaneous	
Customer Information	41
Warranty.....	Back Cover

PRECAUTIONS

Recognize Precautionary Information

Safety-Alert Symbol



The Safety-Alert Symbol is a graphic representation intended to convey a safety message without the use of words. When you see this symbol, be alert to the possibility of death or serious injury. Follow the instructions in the safety message panel.

DANGER

The use of the word DANGER signifies the presence of an extreme hazard or unsafe practice which will most likely result in death or severe injury.

WARNING

The use of the word WARNING signifies the presence of a serious hazard or unsafe practice which could result in death or serious injury.

CAUTION

The use of the word CAUTION signifies possible hazard or unsafe practice which could result in minor or moderate injury.

NOTICE

The use of the word NOTICE indicates information considered important, but not hazard-related, to prevent machine or property damage.

SAFETY INSTRUCTIONS

Indicates a type of safety sign, or separate panel on a safety sign, where safety-related instructions or procedures are described.

General Operational Precautions



Read and understand the Owner's/User's Manual and become thoroughly familiar with the equipment and its controls before operating the dock leveler.

Never operate a dock leveler while a safety device or guard is removed or disconnected.

Never remove DANGER, WARNING, or CAUTION signs, Placards or Decals on the equipment unless replacing them.

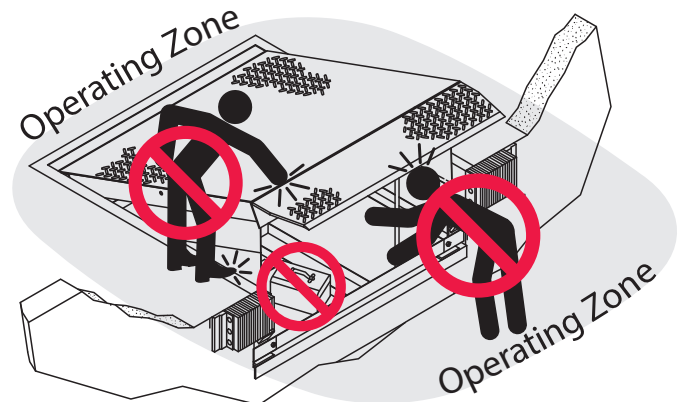

Figure 1

Do not start the equipment until all unauthorized personnel in the area have been warned and have moved outside the operating zone (see Figure 1).

Remove any tools or foreign objects from the operating zone before starting.

Keep the operating zone free of obstacles that could cause a person to trip or fall.



WARNING: This product can expose you to chemicals including lead, which are known to the State of California to cause cancer or birth defects or other reproductive harm. For more information go to www.P65Warnings.ca.gov

PRECAUTIONS

Operational Precautions



Learn the safe way to operate this equipment. Read and understand the manufacturer's instructions. If you have any questions, ask your supervisor.

DANGER



Stay clear of dock leveling device when transport vehicle is entering or leaving area.



Do not move or use the dock leveling device if anyone is under or in front of it.

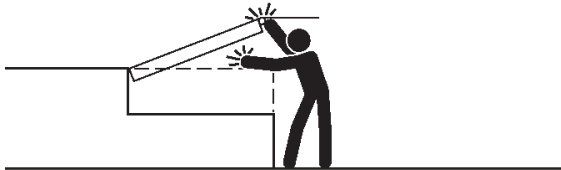

Keep hands and feet clear of pinch points. Avoid putting any part of your body near moving parts.

WARNING



Chock/restrain all transport vehicles. Never remove the wheel chocks or release the restraining device until loading or unloading is finished, and transport driver has been given permission to drive away.



Do not use a broken or damaged dock leveling device or restraining device. Make sure proper service and maintenance procedures have been performed before using.



Make sure lip overlaps onto transport vehicle bed at least 4 in. (102 mm).



Keep a safe distance from both side edges.

Operational Precautions

! WARNING

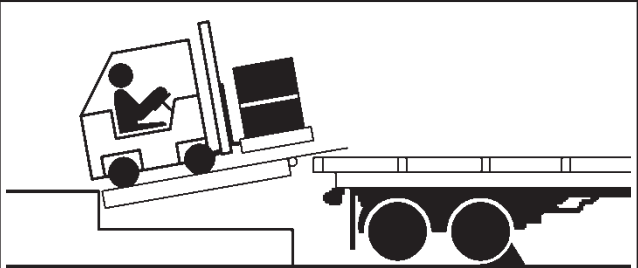

Do not use dock leveling device if transport vehicle is too high or too low.

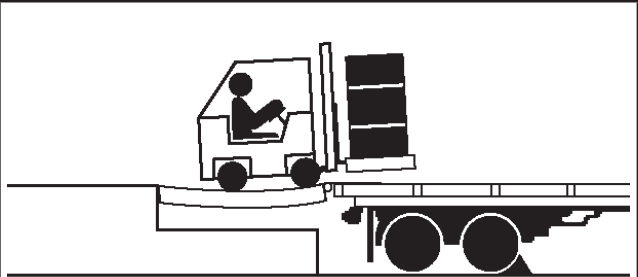

Do not overload the dock leveling device.

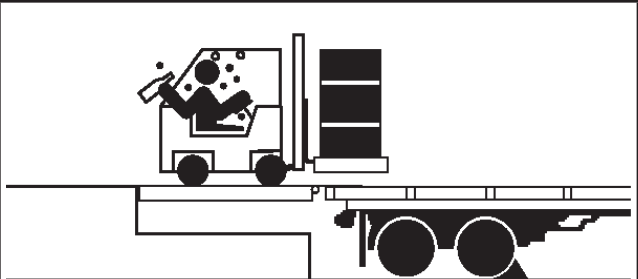

Do not operate any equipment while under the influence of alcohol or drugs.

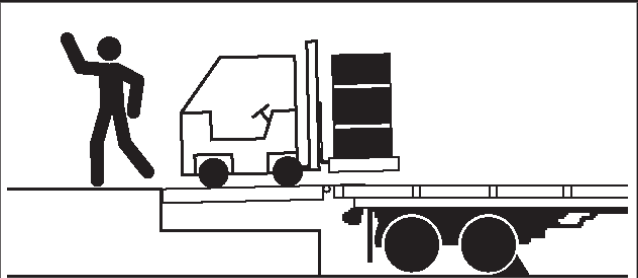

Do not leave equipment or material unattended on dock leveling device.

PRECAUTIONS

Safety Decals



1751-0329



1751-0330 Two positions one on top of each fork pocket.

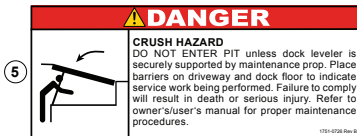

1751-0726

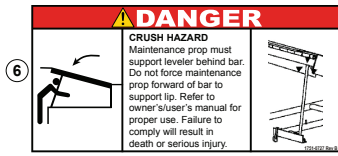

1751-0727



1751-0728

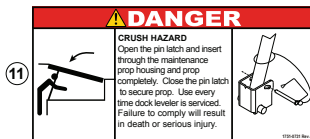

1751-0731



1751-0729

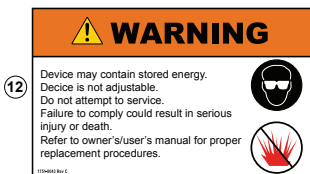

1751-0043

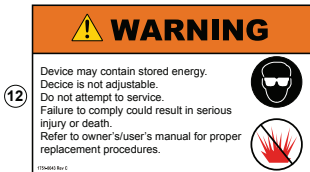

1751-0043

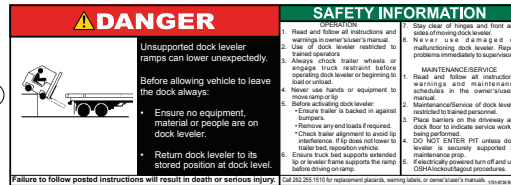
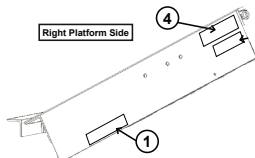

1751-0730

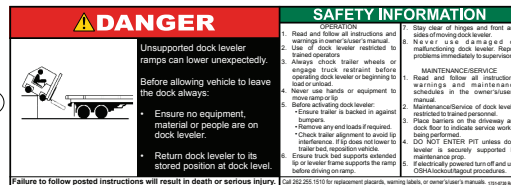

1751-0730

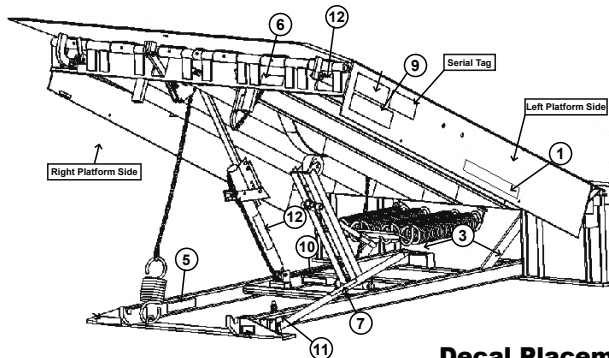

Decal Placement for MP Series

Figure 2

Placard



DANGER

OPERATING INSTRUCTIONS

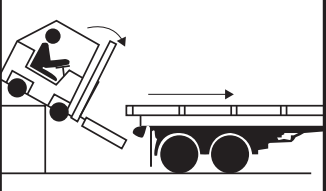

- Read and follow all instructions, warnings, and maintenance schedules in the manual and on placards.
- Operation and servicing of dock leveler is restricted to authorized personnel.

- Always chock transport vehicle wheels or engage vehicle restraint and set parking brakes before operating dock leveler or beginning to load or unload.
- Before activating dock leveler, check to make sure the transport vehicle is positioned squarely against dock bumpers. Ensure lip will avoid contact with transport vehicle frame, sides and cargo during dock leveler activation. If contact is likely or observed, reposition transport vehicle.
- Ensure the transport vehicle floor supports extended lip or the leveler frame (lip keepers or below dock endload supports) supports the ramp before driving on ramp.
- Stay clear of hinges and front and sides of moving dock leveler.
- Never use hands or equipment to move the ramp or lip.
- Never use damaged or malfunctioning dock leveler. Report problems immediately to supervisor.
- Always store dock leveler and remove people, material, and equipment from ramp before vehicle leaves the dock.
- DO NOT ENTER PIT unless dock leveler is securely supported and proper lockout/tagout procedures have been completed. See "Maintenance Precautions" in Owner's/User's Manual.

FAILURE TO FOLLOW THESE INSTRUCTIONS WILL RESULT IN DEATH OR OTHER SERIOUS INJURY.

MECHANICAL DOCK LEVELERS

NORMAL OPERATION

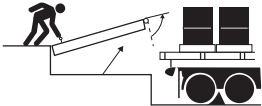

1. Raise the platform by pulling and holding the platform release ring.

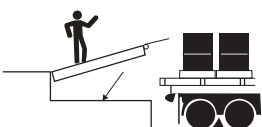

2. Hold the platform release ring until the lip is fully extended, then release the platform release ring. Walk out onto the platform. The platform will lower until lip is resting on the transport vehicle.

STORING LEVELER

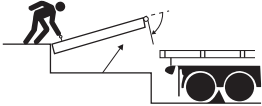

1. Pull the platform release ring. Slowly walk the platform down allowing enough time for the lip to fold, clearing the transport vehicle. Once lip clears transport vehicle, continue to walk leveler to the cross-traffic position.

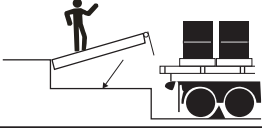

BELOW DOCK ENDLOADING

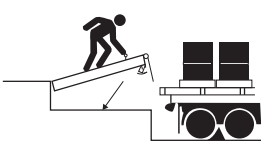

- Pull and hold the platform release ring until the platform is at the fully-raised position. Slowly walk the platform down allowing enough time for the lip to fold. Just before the platform reaches the cross-traffic position, pull and hold the safety leg retract pull ring located in a recess at front of the platform. The platform will continue lowering to the full below dock position.



Scan to view our owner's/user's manuals online.
www.LoadingDockSystems.com
1.800.643.5424
Call for additional placards, or manuals, or with questions regarding proper use, maintenance, and repair of dock leveler.



WARNING: CANCER AND REPRODUCTIVE HARM
www.P65Warnings.ca.gov

1751-0875 Rev D

1751-0875

OWNER'S/USER'S RESPONSIBILITIES

- 1) The manufacturer shall provide to the initial purchaser and make the following information readily available to the owners/users and their agents, all necessary information regarding Safety Information, Operation, Installation and Safety Precautions, Recommended Initial and Periodic Inspections Procedures, Planned Maintenance Schedule, Product Specifications, Troubleshooting Guide, Parts Break Down, Warranty Information, and Manufacturers Contact Information, as well as tables to identify the grade(slope) for all variations of length or configuration of the dock leveling device and information identifying the maximum uncontrolled drop encountered when sudden removal of support while in the working range of the equipment.
- 2) When selecting loading dock safety equipment, it is important to consider not only present requirements but also future plans and any possible adverse conditions, environmental factors or usage. The owners/users shall provide application information to the manufacturer to receive recommendations on appropriate equipment specifications and capacity.
- 3) The owner/user must see all nameplates, placards, decals, instructions and posted warnings are in place and legible and shall not be obscured from the view of the operator or maintenance personnel for whom such warnings are intended for. Contact manufacturer for any replacements.
- 4) Dock leveling devices may become hazardous if the manufacturer's instructions regarding modifications or adjustments are not followed. Modifications or alterations of dock leveling devices shall only be made with prior written approval from the original manufacturer. These changes shall be in conformance with all applicable provisions of the MH30.1 standard and shall also satisfy all safety recommendations of the original equipment manufacturer of the particular application.
- 5) The owner/user should recognize the inherent dangers of the interface between the loading dock and the transport vehicle. The owner/ user should, therefore, train and instruct all operators in the safe operation and use of the loading dock equipment in accordance with manufacturer's recommendations and industry standards. Effective operator training should also focus on the owner's/user's company policies, operating conditions and the manufacturer's specific instructions provided with the dock leveling device. Maintaining, updating and retraining all operators on safe working habits and operation of the equipment, regardless of previous experience, should be done on a regular basis and should include an understanding and familiarity with all functions of the equipment. Owners/users shall actively maintain, update and retrain all operators on safe working habits and operations of the equipment.
- 6) An operator training program should consist of, but not necessarily be limited to, the following:
 - a) Select the operator carefully. Consider the physical qualifications, job attitude and aptitude.
 - b) Assure that the operator reads and fully understands the complete manufacturer's owners/users manual.
 - c) Emphasize the impact of proper operation upon the operator, other personnel, material being handled, and equipment. Cite all rules and why they are formulated.
 - d) Describe the basic fundamentals of the dock leveling device and components design as related to safety, e.g., mechanical limitation, stability, functionality, etc.
 - e) Introduce the equipment. Show the control locations and demonstrate its functions. Explain how they work when used properly and maintained as well as problems when they are used improperly.
 - f) Assure that the operator understands the capacity rating, nameplate data, placards and all precautionary information appearing on the dock leveling device.
 - g) Supervise operator practice of equipment.
 - h) Develop and administer written and practical performance tests. Evaluate progress during and at completion of the course.
 - i) Administer periodic refresher courses. These may be condensed versions of the primary course and include on-the-job operator evaluation.

OWNER'S/USER'S RESPONSIBILITIES

- 7) Loading dock safety equipment should never be used outside of its vertical working range, or outside the manufacturer's rated capacity. It shall also be compatible with the loading equipment and other conditions related to dock activity. Please consult the manufacturer if you have any questions as to the use, vertical working range or capacity of the equipment. Only properly trained and authorized personnel should operate the equipment.
- 8) It is recommended that the transport vehicle is positioned as close as practical to the dock leveling device and in contact with both bumpers. When an industrial vehicle is driven on or off a transport vehicle during loading and unloading operations, the transport vehicle parking brakes shall be applied and wheel chocks or a restraining device that provides equal or better protection of wheel chocks shall be engaged. Also, whenever possible, air-ride suspension systems should have the air exhausted prior to performing said loading and unloading operations.
- 9) When goods are transferred between the loading dock and a trailer resting on its support legs/ landing gear instead of a tractor fifth wheel or converter dolly, it is recommended that an adequate stabilizing device or devices shall be utilized at the front of the trailer.
- 10) In order to be entitled to the benefits of the standard product warranty, the dock safety equipment must have been properly installed, maintained and operated in accordance with all manufacturer's recommendations and/ or specified design parameters and not otherwise have been subject to abuse, misuse, misapplication, acts of nature, overloading, unauthorized repair or modification, application in a corrosive environment or lack of maintenance. Periodic lubrication, adjustment and inspection in accordance with all manufacturers' recommendations are the sole responsibility of the owner/user.
- 11) Manufacturer's recommended maintenance and inspection of all dock leveling devices shall be performed in conformance with the following practices: A planned maintenance schedule program must be followed, only trained and authorized personnel shall be permitted to maintain, repair, adjust and inspect dock leveling devices, and only the use of original equipment manufacturer parts, manuals, maintenance instructions, labels, decals and placards or their equivalent. Written documentation of maintenance, replacement parts or damage should be kept. In the event of damage, notification to the manufacturer is required.
- 12) Loading dock devices that are structurally damaged or have experienced a sudden loss of support while under load, such as might occur when a transport vehicle is pulled out from under the dock leveling device, shall be removed from service, inspected by a manufacturer's authorized representative, and repaired or replaced as needed or recommended by the manufacturer before being placed back in service.

INTRODUCTION

General Information



Figure 3

This manual provides current information on the MP-series dock leveler. Due to ongoing product improvement, some parts may have changed, along with operation and troubleshooting methods. This manual describes these changes where applicable.

The MP-series mechanical dock leveler design allows finger tip release pull chain activation with smooth reliable operation via a cam and roller counterbalance to assure smooth dependable walk down to trailer bed with below dock capability included.

The hold down design floats with air ride trailers and the full width rear compression hinge is designed for superior strength.

Each MP-series dock leveler has been factory tested to ensure satisfactory operation.

MP dock levelers are available in the following sizes, weight capacities, and options:

Width

6 ft (1829 mm)
6-1/2 ft (1981 mm)
7 ft (2134 mm)

Length

6 ft (1829 mm)
8 ft (2438 mm)
10 ft (3048 mm)

Capacity (CIR*)

25,000 lb (11 340 kg)
30,000 lb (13 608 kg)
35,000 lb (15 876 kg)
40,000 lb (18 144 kg)
45,000 lb (20 412 kg)
55,000 lb (22 680 kg)

* CIR (Comparative Industry Rating)

Call McGuire to discuss available options to meet your specific needs.

Technical Service at 800-643-5424 or techservices@docksystemsinc.com

Component Identification

Inspect package and all components. Report any missing or damaged items immediately and note on the shipping Bill Of Lading (BOL).

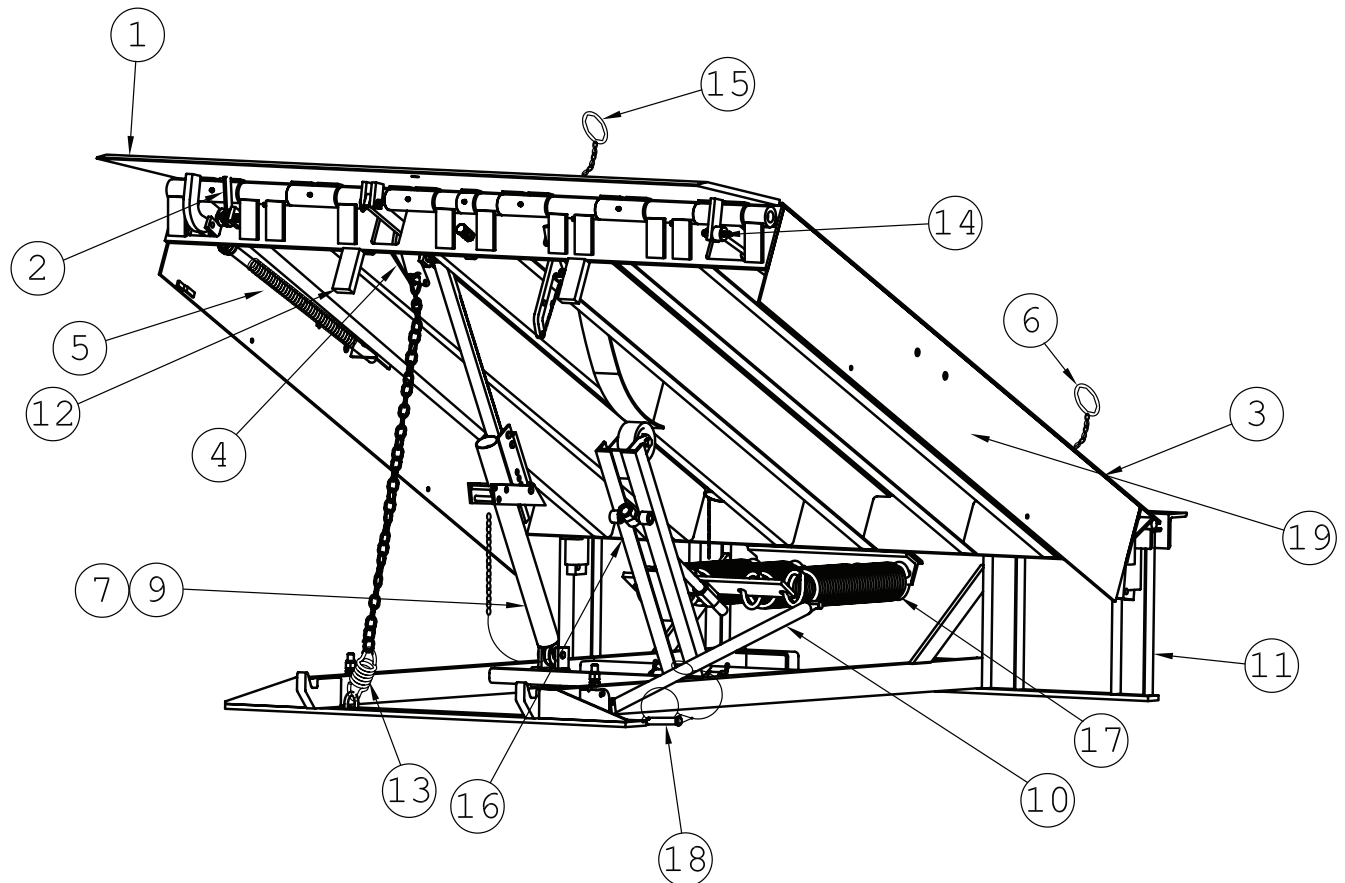

Figure 4

- | | | | |
|--------------------------|--------------------------------|---------------------------|-------------------------------|
| 1 — Lip | 6 — Hold Down Release Ring | 11 — Main Base Frame | 15 — Safety Leg Pull Chain |
| 2 — Lip Maintenance Prop | 7 — Ratchet Pawl & Bar | 12 — Safety Leg Assy. | 16 — Lift Arm Assembly |
| 3 — Platform | 9 — Hold Down | 13 — Lip (Snubber) Spring | 17 — Lift (Main) Spring |
| 4 — Bell Crank | 10 — Platform Maintenance Prop | 14 — Lip Shock Absorber | 18 — Prop. Pin and Clip |
| 5 — Lip Assist Spring | | | 19 — Working Range Toe Guards |

INSTALLATION

Installation Precautions

DANGER

It is recommended and good safety practice to use an additional means to support the dock platform and lip anytime when physically working in front of or under the dock leveler. This additional means may include, but is not limited to a boom truck, fork truck, stabilizing bar or equivalent.

WARNING

Post safety warnings and barricade the work area at dock level and ground level to prevent unauthorized use of the dock leveler before installation has been completed.

WARNING

DO NOT grind or weld if hydraulic fluid or other flammable liquid is present on the surface to be ground or welded.

DO NOT grind or weld if uncontained hydraulic fluid or other flammable liquid is present. Stray sparks can ignite spills or leaks near the work area. Always clean up the oil leaks and spills before proceeding with grinding or welding.

Always keep a fire extinguisher of the proper type nearby when grinding or welding.

WARNING

A hard hat or other applicable head protection should always be worn when working under or around a dock leveler.

Always stand clear of platform lip when working in front of the dock leveler.

CAUTION

Only trained installation professionals with the proper equipment should install this product.

Leveler Forklift Pick-Up*

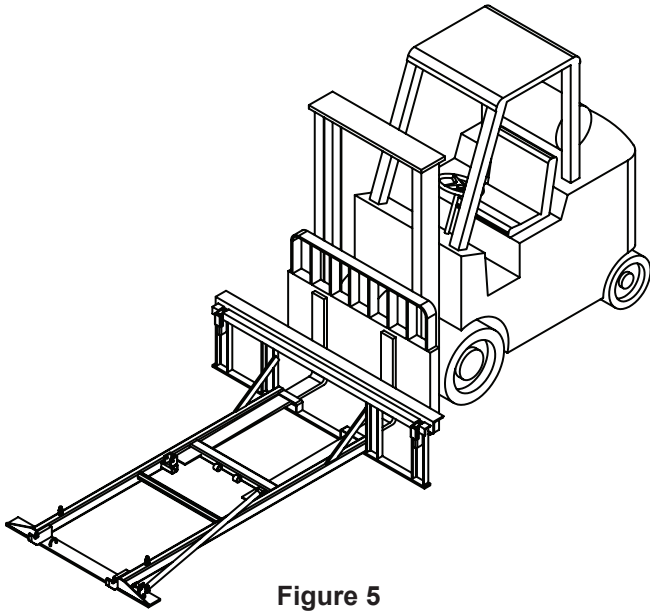

Figure 5

Rear Pick-Up (recommended)

To pick up the dock leveler from the rear, slide forks into the fork slots and under the cross member as shown in Figure 5.

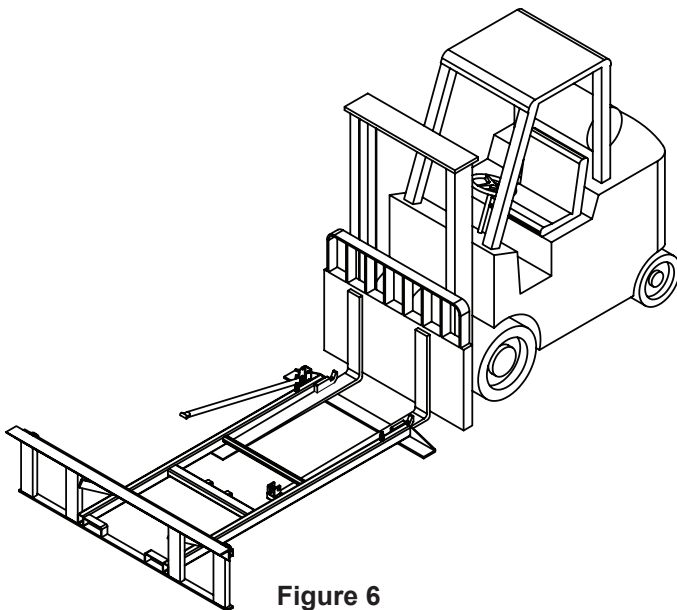

Figure 6

Front Pick-Up

To pick up the dock leveler from the front, move forks closer together and slide over the frame and under the crossmember as shown in Figure 6. It may be necessary to remove the shipping bands from the unit to gain access to the front, by lifting the lip up then sliding the forks under the cross member.

* Dock leveler platform not shown for clarity.

INSTALLATION

Prepare Pit

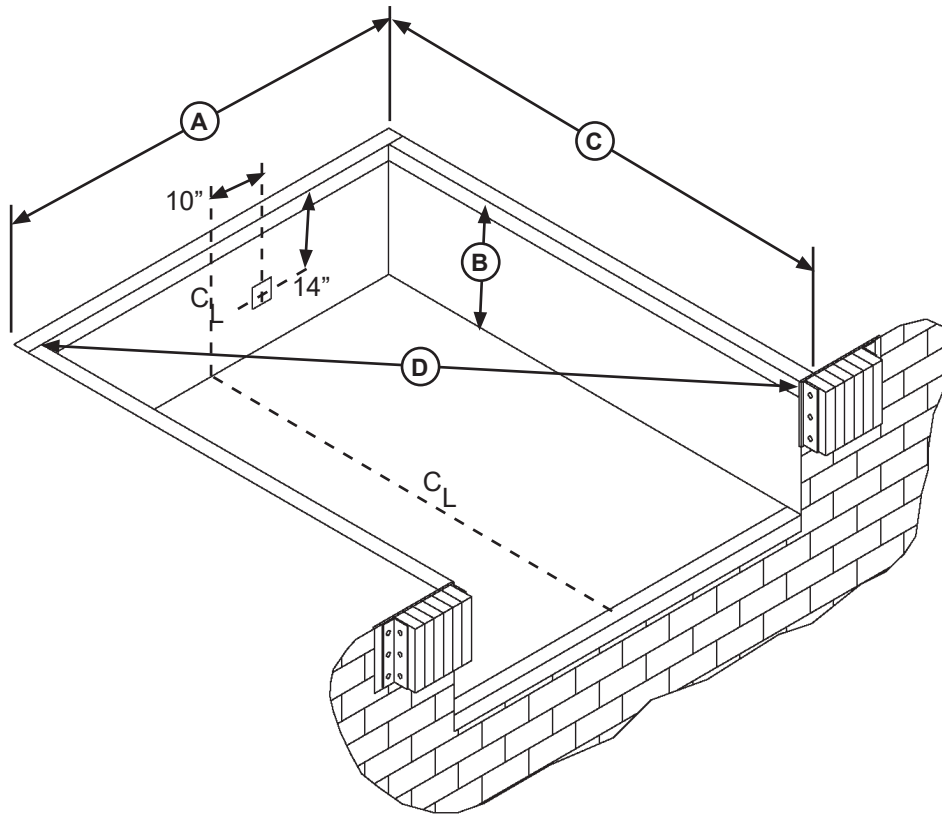

Figure 7

A—Pit Width
(Front and Rear)

B— Dock Floor-to-Pit Floor
(All Four Corners)

C— Pit Length
(Both Sides of Pit)

D— Pit Corner-to-Corner
(Top, Bottom, and Both Sides)

Before lowering the dock leveler into the pit, the following must be performed:

1. Remove all debris from the pit and sweep the pit clean.
2. Check the entire dock leveler pit for proper construction according to approved/certified pit drawings. Make sure pit is square by making the following measurements (see Figure 7):
 - Measure pit width distance (A) at both front and rear of pit.
 - Measure dock floor-to-pit floor distance (B) at all four corners.
 - Measure pit length distance (C) at both sides.
 - Measure corner-to-corner (diagonal) distance (D) at both sides. Take measurements at dock floor level and at pit floor level.

If any measurement is off by more than 1/8 in. (3.2 mm), contact Systems, LLC Technical Services before proceeding.

Note: If a junction box is required for electrical components (such as interlock switches), locate it 10" off center and 14" down from the curb as shown.

Prepare Dock Leveler

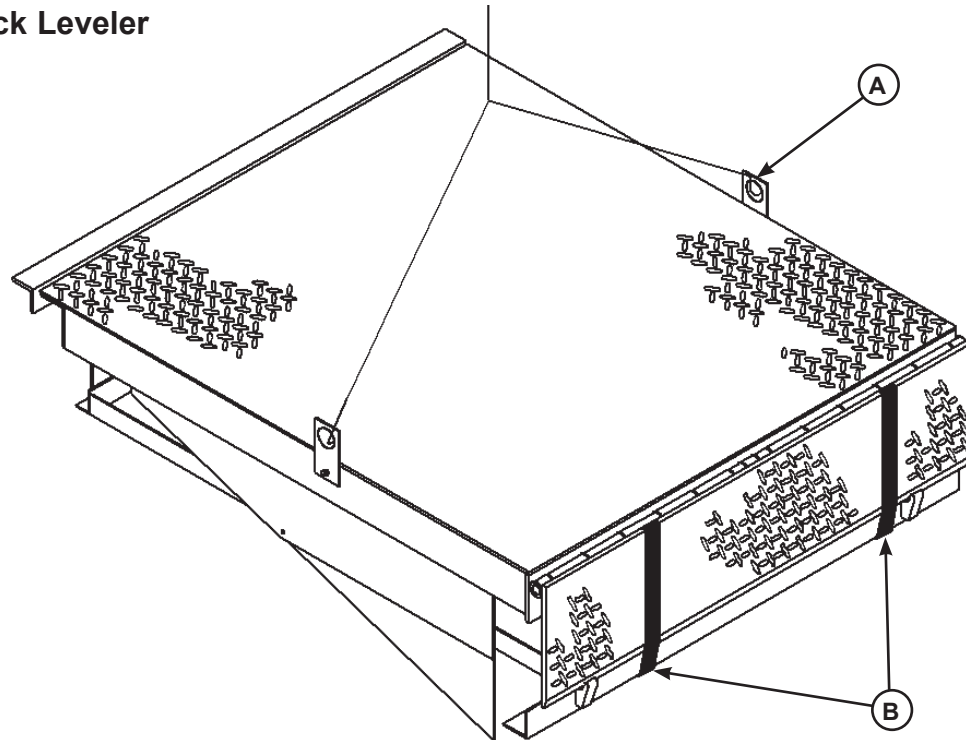

Figure 8

A— Lifting Bracket (2 used)

B — Shipping Bands

McGuire dock levelers are shipped with lifting brackets (A) fastened to the platform side joists, and shipping bands (B) around the platform lip and leveler frame (see Figure 8).

1. Remove any bumpers and/or control panels that may be banded to the frame of the dock leveler.

3. Attach lifting chains to lifting brackets (A) and to a lifting device (i.e., hoist or fork truck) having the appropriate lifting capacity and reach.

4. Remove wood blocks that are attached to the leveler frame before putting the dock leveler into the pit.

5. Proceed to “Install Dock Leveler” on Page 14.

NOTICE

DO NOT remove the shipping bands (B) around the platform lip and leveler frame at this time. The shipping bands are needed to hold the leveler together during the installation process.

Note: Overall width of platform and lifting brackets (A) must be kept to a minimum to prevent interference between the lifting brackets and the pit walls as the dock leveler is lowered into the pit.

2. Make sure the mounting hardware of lifting brackets (A) is snug. The brackets should pivot without binding on the mounting cap screw.

NOTICE

DO NOT over-tighten the lifting bracket hardware. Over-tightening can damage the weather seal, if equipped.

INSTALLATION

Install Dock Leveler

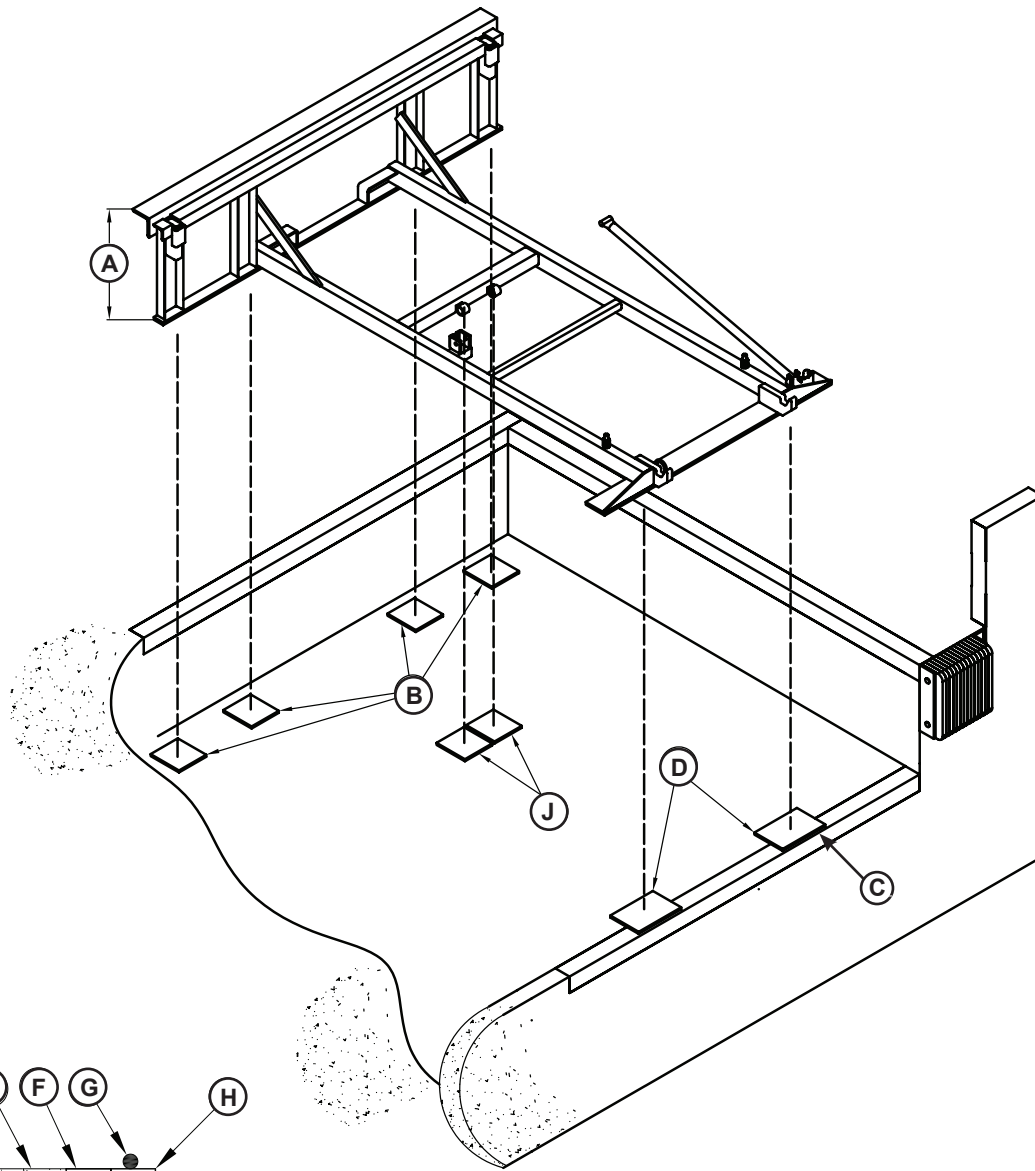

Figure 9

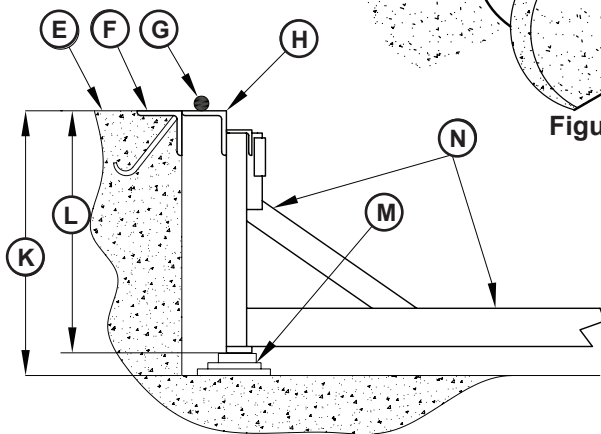

Figure 10

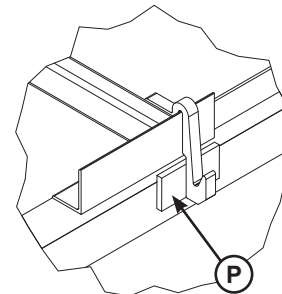

Figure 11

- | | | | |
|--|---------------------------------------|---------------------------------------|---|
| A— Distance (Leveler Frame Height) | D— Shim Locations (Under Lip Keepers) | H— Rear Hinge Frame Angle | L— Distance (Top of Shim Stack-to-Dock Floor) |
| B— Shim Locations (Under Rear Vertical Supports) | E— Dock Floor | J— Shims Location (Under Lift Arm) | M— Shim Stack |
| C— Shim Location (Under Maintenance Prop) | F— Rear Pit Curb Angle | K— Distance (Dock Floor-to-Pit Floor) | N— Dock Leveler Frame |
| | G— String | | P— Lip Keeper Shim (as required) |

Install Dock Leveler (continued)

Note: McGuire dock levelers are designed with a nominal 1/2" (12.7 mm) shimming distance to allow for pit inconsistencies.

1. Determine height of shim stack (**M**) for each shim location (**B**) by performing the following:

- a. Measure leveler frame height distance (**A**).
- b. Measure dock floor-to-pit floor distance (**K**) at each shim location (**B**). Write down the dimensions obtained at each location.
- c. Subtract distance (**A**) from distance (**K**) to obtain the shim height. Repeat for each shim location.

2. Using the results obtained in step 1, create the individual shim stacks on the pit floor at location (**B**). Build each shim stack (**M**) with the top shim having a minimum size of 4-1/2" x 4-1/2" (114.3 mm x 114.3 mm) and each successive lower shim being larger so the shims can be welded together using a fillet weld. If using offset method, make sure load is over center of shim stack, NOT over the edge. DO NOT use straight method. See Figure 12.

NOTICE

The minimum size of the shim that contacts the leveler frame (i.e. the top shim of each shim stack) must be at least 4-1/2" x 4-1/2" (114.3 mm x 114.3 mm) to support the full width of the frame rail and to provide a shelf for a fillet weld.

Use the thickest shim stock possible for stability and weld penetration purposes. DO NOT use multiple layers of 1/8 in. (3.2 mm) or thinner shim stock.

Note: To assist in obtaining an accurate measurement of distance (**L**), use a string (**G**) pulled tight across the pit opening, directly over the shim locations.

3. Verify that each shim stack is at the correct height by measuring distance (**L**) [top of shim stack (**M**) to dock floor]. Distance (**L**) must equal the dock leveler height (**A**).

4. Put a 1/4 in. (6.4 mm) thick shim at locations (**C** and **D**).

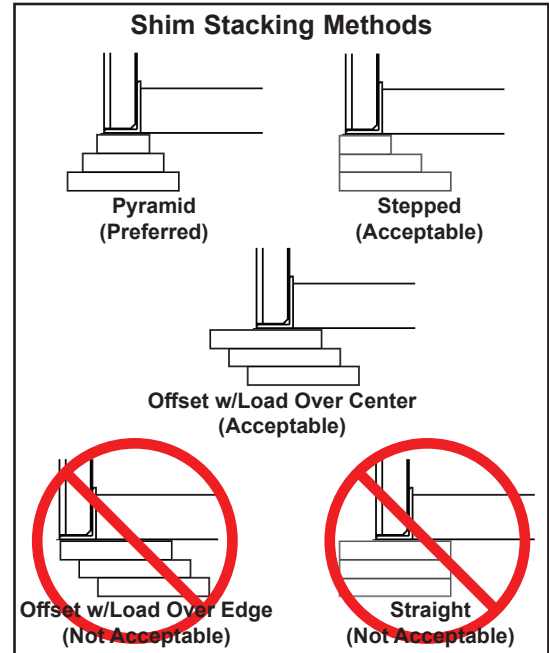

Figure 12

Note: A 1/4" (6.4 mm) thick shim at locations (**C** and **D**) are used only as a starting point. The final shim stack height will be determined after dock leveler is lowered into the pit.

5. Using an appropriate lifting device connected to the lifting brackets, lower dock leveler into the pit so rear hinge frame angle (**H**) is tight against rear pit curb angle (**F**) across full width of the leveler frame.

WARNING

The dock leveler is heavy. Use a lifting device and chains with the appropriate lifting capacity and reach.

Always use the lifting brackets provided with the unit whenever lowering or lifting a dock leveler into or out of a pit.

6. Allow rear of dock leveler to rest on the rear shims while keeping the front of the dock leveler level with the dock floor.

7. Add shims at front shim locations (**C** and **D**) so front of dock leveler will stay level with dock floor when leveler is resting fully on shims.

INSTALLATION

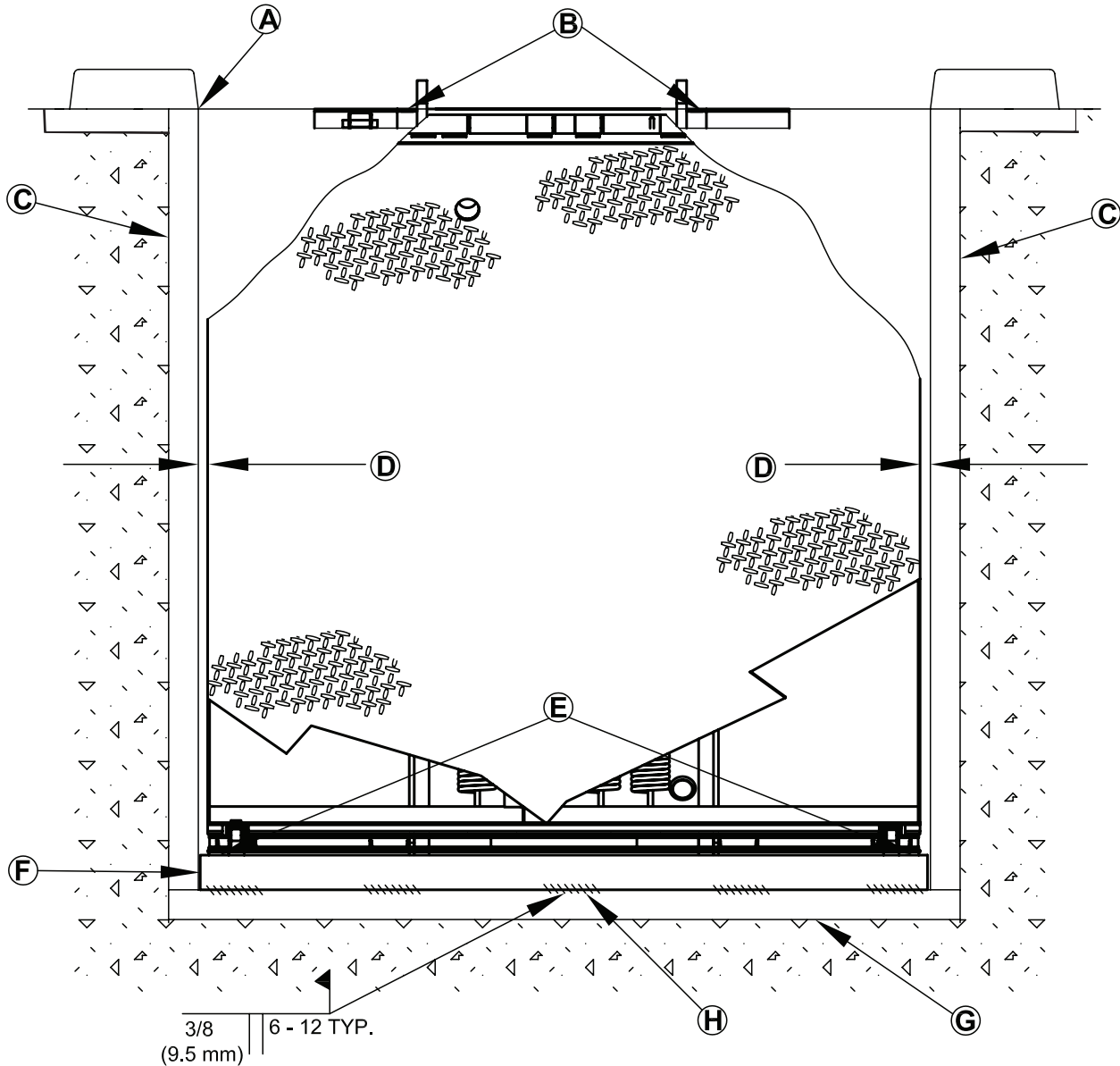

Figure 13

- | | | | |
|-----------------------|----------------------------------|---------------------------|---|
| A— Front of Dock Pit | C— Side Pit Curb Angle | E— Pry Locations | G— Rear Pit Curb Angle |
| B— Dock Leveler Frame | D— Gap [3/4 in. (19 mm) Minimum] | F— Rear Hinge Frame Angle | H— Flare Bevel Weld, Typical (To Fit Spacing) |

8. With rear hinge frame angle (F) tight against rear pit curb angle (G), perform/check the following:

- Pry between the platform and rear hinge frame angle at locations (E) to make sure rear edge of platform is parallel to the rear hinge frame angle (F).
- Gap (D) must exist equally along both sides of leveler so weather seal (if equipped) will not bind during dock leveler operation.

9. If gap (D) cannot be obtained equally at both sides of leveler, grind or add material at the rear edge of rear hinge frame angle (F) as needed.

10. Allow the dock leveler to rest fully on the shim stacks. Check that a smooth and level transition exists between the dock floor and the dock leveler platform. Add or remove shims as necessary until a smooth transition is obtained.

11. If leveler cannot be squared and/or made level as instructed in steps 8-10, contact Systems, LLC Technical Services.

Install Dock Leveler (continued)

NOTICE

DO NOT weld continuously along the full length of the rear hinge frame angle. This can put unnecessary stress on the leveler components, causing the leveler to malfunction and shorten the lifespan of the affected components.

12. With the rear hinge frame angle (**F**) tight against the rear pit curb angle (**G**), weld the rear hinge frame angle (**F**) to the rear pit curb angle (**G**) using a 3/8 in. (9.5 mm) flare bevel skip weld — each weld being 6 in. (152 mm) long.

- Start at each end with a 6 in. (152 mm) long weld. Space all the other welds out evenly, leaving approximately 6 in. (152 mm) space between each weld.

Note: Figure 13 shows a typical weld pattern. The weld pattern will vary slightly depending on size of dock leveler.

13. Prior to welding front of frame to curb steel, remove the shipping bands from around lip and leveler frame. Operate leveler through full cycle 4-6 times and walk the platform into stored position.

14. Allow platform and lip to float out of lip keepers, and shim under front of frame as required to level top of platform with dock floor.

15. Weld front of dock leveler frame (**B**) to shims located under the keepers, then weld the shims to the front pit curb steel.

16. Disconnect lifting device and chains from the lifting brackets.

17. Pull and hold the release ring (located in recess at rear of platform) until the platform is fully raised. Check for binding as platform rises.

18. Slowly walk out onto the platform to lower the platform. Allow the platform to lower to the cross-traffic position. Check for binding as platform lowers.

19. If binding occurs, reposition leveler and/or add or remove shims as necessary. Raise and lower platform again. If platform still binds, contact Technical Services for further instructions.

20. Check that the leveler is flush with the dock floor and that the platform lip contacts both lip keepers evenly.

INSTALLATION

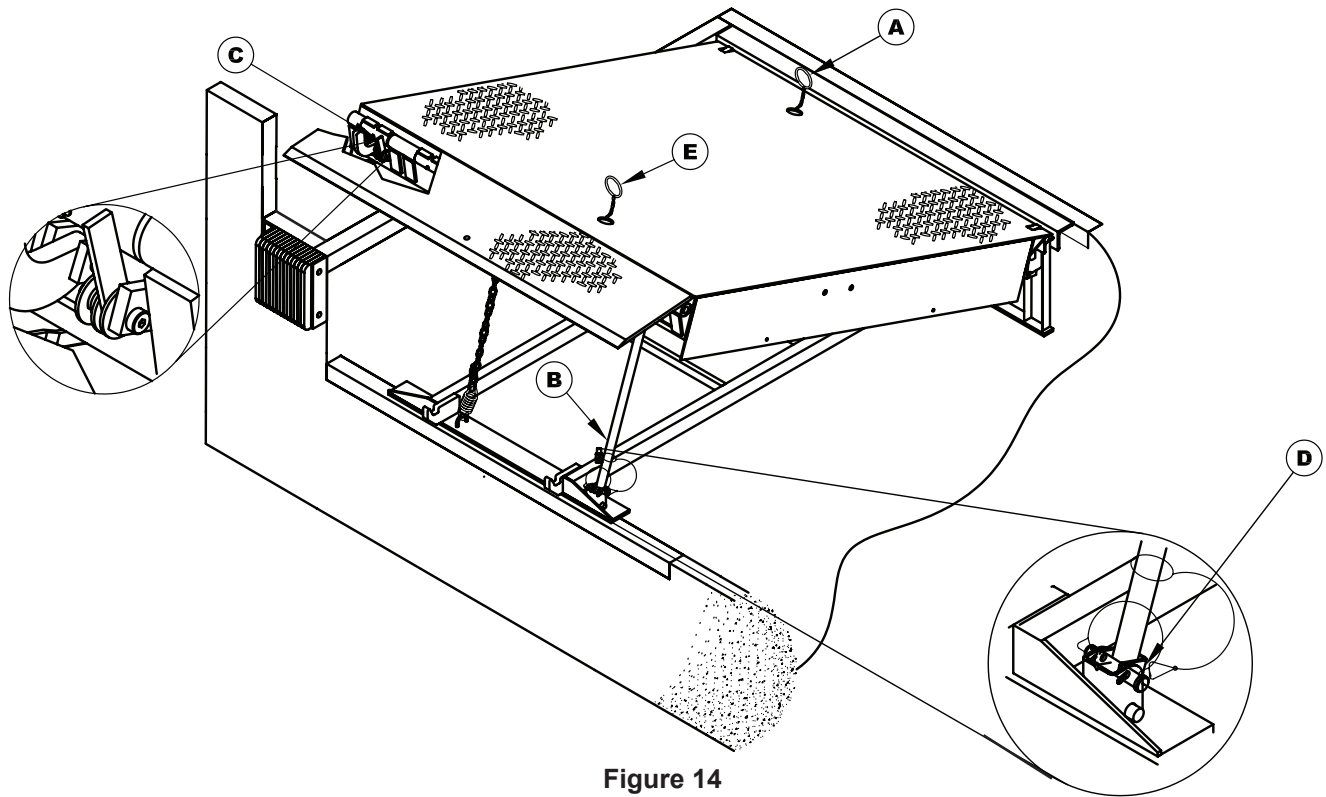

Figure 14

A— Hold-Down Release Ring
B— Maintenance Prop

C— Lip Maintenance Prop
D— Prop Pin and Clip

E— Safety Leg Chain

21. Pull the release ring (A) to raise the platform. Engage lip maintenance prop (C).
22. Shim and weld the maintenance prop (Figure 14):
 - a. Install shims under maintenance prop (B) where prop attaches to leveler frame. Make sure prop is solidly shimmed.
 - b. Raise maintenance prop (B) to the service (upright) position and lock prop in this position using an OSHA approved locking device.
 - c. Proceed to step 23.

23. Install shims under lift arm (J, Figure 9 on page 14) at locations using an acceptable shimming method (see Figure 15). The lift arm pivot must be solidly shimmed the entire length of the lift arm pivot. Make sure the lift arm pivot is level from side-to-side.
24. Finish weld all shims using a fillet weld:
 - Weld all shims within each shim stack to each other, then weld the shim stack to the leveler frame.
 - Weld the front leveler frame shim stacks to the front pit curb steel.

! WARNING

DO NOT use the maintenance prop to support the raised platform until the maintenance prop has been properly shimmed and welded. The shims must be welded to each other, and also to the leveler frame.

! WARNING

Make sure the platform is properly supported in the raised position before entering the pit to finish weld the shims.

25. Remove the lifting brackets from the platform side joists.
26. Disengage the platform maintenance prop.

Install Dock Leveler (continued)

27. Slowly walk out onto the platform to lower the platform until it is at the cross-traffic (stored) position.

28. Check operation of dock leveler by cycling the leveler at least four times:

- When the platform is at full height, lip will be fully extended.
- Lip will begin to drop after the unit begins to lower to truck bed.

29. Check below-dock position by walking platform down before lip folds completely:

- Lip will be over lip keepers.
- Platform safety legs will be resting on frame.

30. Check full below-dock position by walking the platform down. Pull and hold safety leg chain (E) before lip folds completely.

Note: If the lip does not extend fully or lip folds too quickly, see appropriate symptom in the Troubleshooting section.

31. When all welding has been completed, paint all the welds and shims.

32. Install the dock bumpers as required.

33. Install placard (see page 20).

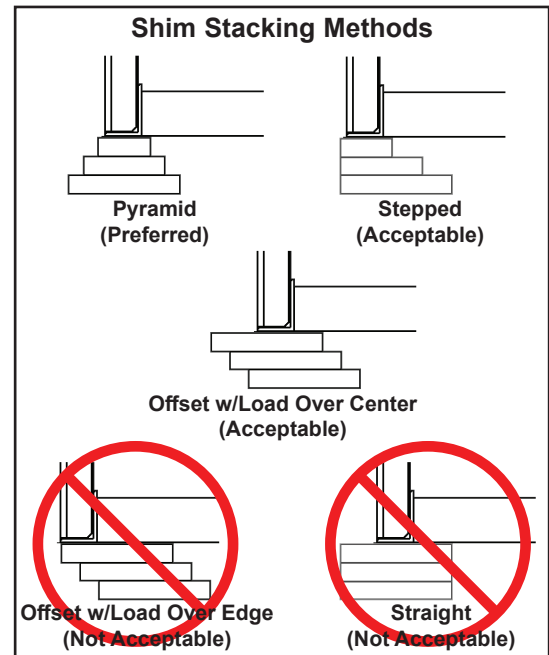

Figure 15

INSTALLATION

Placard Installation Instructions

- Owner/Users are responsible for the installation and placement of product placards.
- Make sure placard is in plain view of dock leveler and/or vehicle restraint operations.
- Suggested placement of placard is near control box attached to electrical conduit by using nylon cable tie. If there is no control box present, mount placard on wall to the immediate left of leveler at eye level.

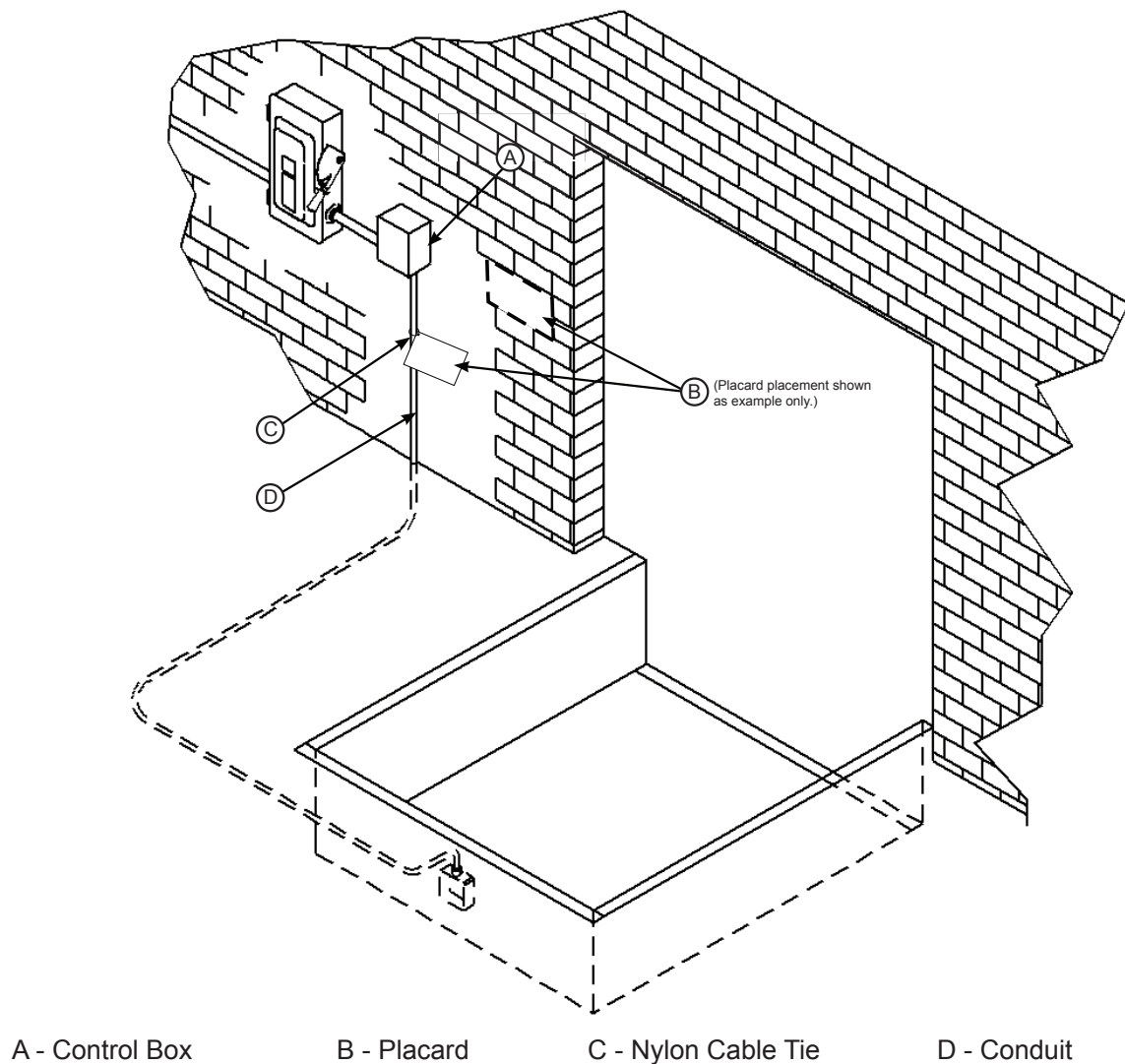

Figure 16

Operational Precautions

DANGER

Stay clear of dock leveler and vehicle restraint when transport vehicle is entering or leaving dock area.

DO NOT move or use the dock leveler or restraint if anyone is under or in front of leveler.

Keep hands and feet clear of pinch points. Avoid putting any part of your body near moving parts.

WARNING

Only trained personnel should operate the dock leveler.

DO NOT use a broken or damaged dock leveler. Make sure proper service and maintenance procedures have been performed on leveler before using.

Transport vehicle wheels must be chocked unless a vehicle restraint is used. Never remove the wheel chocks until loading/unloading is finished and transport driver has been given permission to leave.

Make sure platform lip rests on the transport vehicle bed with at least 4 in. (102 mm) of overlap.

Maintain a safe distance from side edges of leveler during the loading/unloading process.

NOTICE

When activating the leveler, always pull swiftly AND hold the platform release ring until the platform is at the full raised position. Releasing the ring while the platform is still raising may result in damage to the equipment.

WARNING

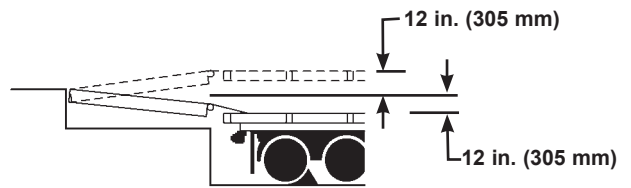

The MP mechanical dock leveler is designed to compensate for a maximum ± 12 in.* (305 mm) of height difference between the loading dock and the transport vehicle's bed. DO NOT use the dock leveler if the transport vehicle's bed is more than 12 in. (305 mm) higher or lower than the dock floor.

*Service height may vary with design specifications.

DO NOT overload the dock leveler.

DO NOT operate any equipment while under the influence of alcohol or drugs.

DO NOT leave equipment or material unattended on the dock leveler.

OPERATION

Operating Instructions

Ramp Loading/Unloading

1. Before activating dock leveler, check to make sure the transport vehicle is positioned squarely against dock bumpers. Ensure lip will avoid contact with transport vehicle frame, sides and cargo during dock leveler activation. If contact is likely or observed, reposition transport vehicle.

2. Instruct driver to remain at the dock until the loading or unloading process has been completed.

3. Chock the transport vehicle wheels, or use a vehicle restraint if available.

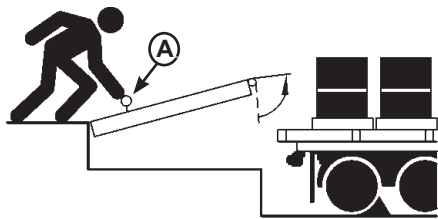

Figure 15

4. Raise the platform by pulling and holding the platform release ring (A).

5. Hold the release ring until the platform is at the fully-raised position and lip is fully extended.

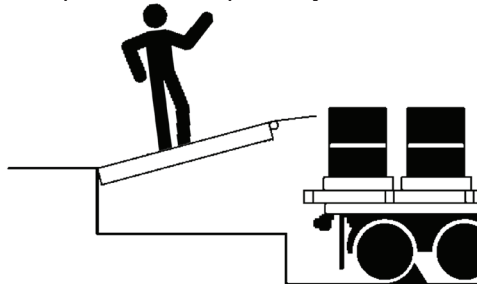

Figure 16

6. Walk out onto the platform. The platform will lower until the lip rests on the transport vehicle bed.

7. Make sure that the lip is fully extended and supported on the transport vehicle along the entire width of the platform with at least 4 in. (102 mm) of lip contacting the transport vehicle bed.

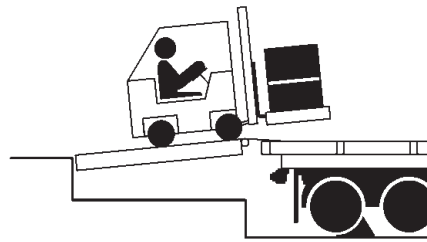

Figure 17

8. Proceed with loading or unloading the transport vehicle.

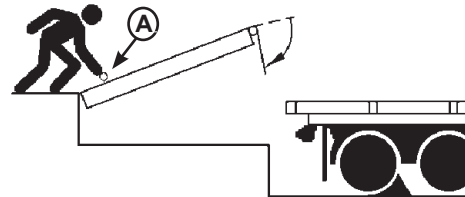

Figure 18

9. When the loading or unloading process has been completed, return platform to cross-traffic (stored) position as follows:

a. Raise the platform to the full-raised position by pulling and holding the platform release ring (A).

b. Lower platform by slowly walking out onto the platform allowing time for the lip to fully fold and clear the transport vehicle. Continue walking out on platform until platform lowers to the cross-traffic position (lip engages in the lip keepers).

10. Remove chocks from transport vehicle wheels, or release the vehicle restraint if used.

11. Indicate to driver that the transport vehicle may leave the dock.

Operating Instructions (continued)

End Loading/Unloading

1. Before activating dock leveler, check to make sure the transport vehicle is positioned squarely against dock bumpers. Ensure lip will avoid contact with transport vehicle frame, sides and cargo during dock leveler activation. If contact is likely or observed, reposition transport vehicle.

2. Instruct driver to remain at the dock until the loading or unloading process has been completed.

3. Chock the transport vehicle wheels, or use a vehicle restraint if available.

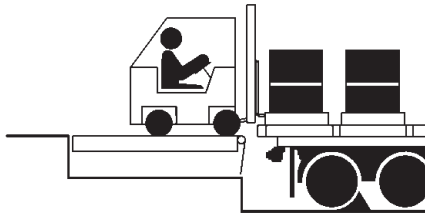

Figure 19

4. If transport vehicle bed is at or above dock floor level, leave leveler at the cross-traffic position and proceed with loading or unloading. If transport vehicle bed is below the dock level, continue with Step 5.

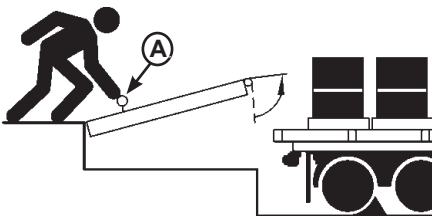

Figure 20

5. Pull and hold the platform release ring (A) until the platform is at the fully-raised position.

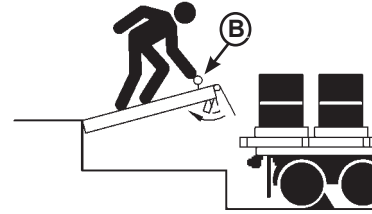

Figure 21

6. Slowly walk the platform down allowing enough time for the lip to fold. Just before the platform reaches the cross-traffic position, pull and hold the safety leg retract pull ring (B, located in a recess at front of the platform). The platform will continue lowering to the full below dock position.

7. Proceed with loading or unloading.

Note: When end unloading is finished and access to the rest of the transport vehicle is still required, the platform lip will need to be extended. See Ramp Loading/Unloading Instructions on page 22 for further instructions.

8. When loading or unloading is finished, raise the platform to the full-raised position by pulling and holding the platform release ring. Slowly walk the platform down, allowing enough time for the lip to fold. The platform will lower to the cross-traffic position (lip engages in the lip keepers).

9. Remove chocks from transport vehicle wheels, or release the vehicle restraint if used.

10. Indicate to driver that the transport vehicle may leave the dock.

MAINTENANCE

Maintenance Precautions

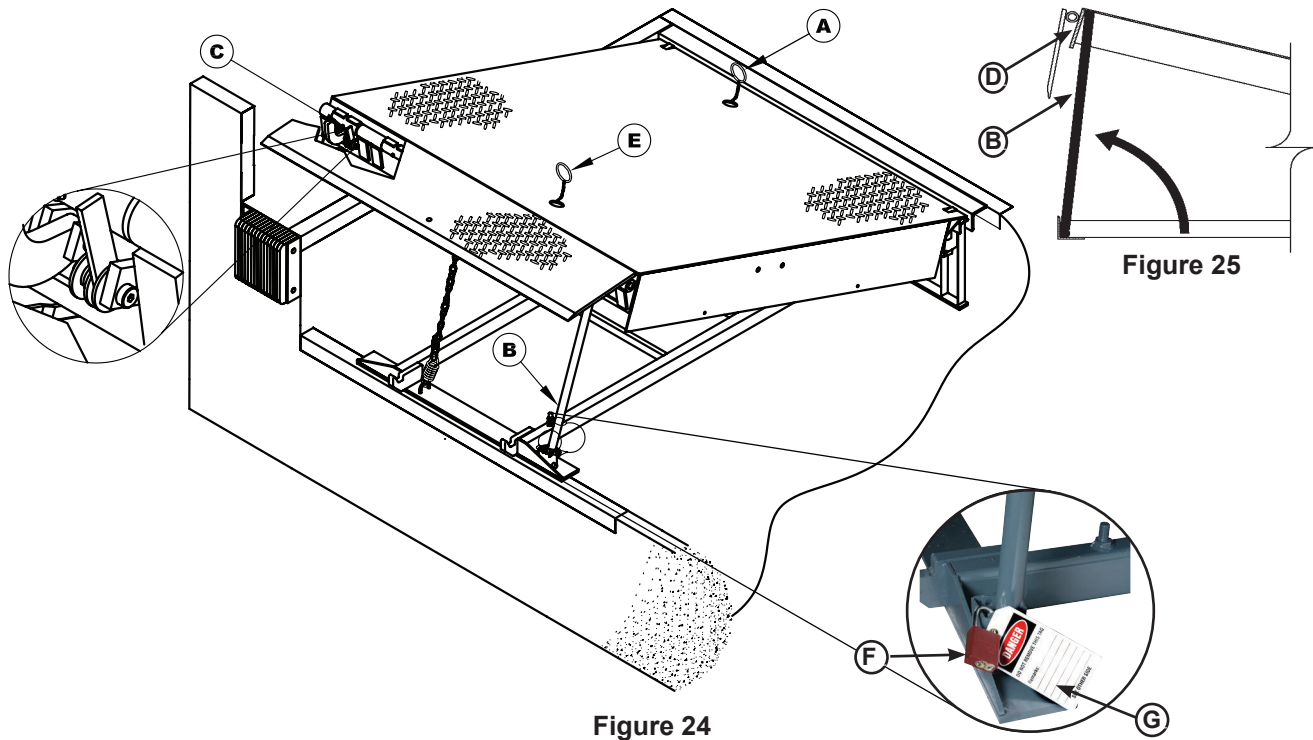

Figure 24

A - Platform Release Ring
B - Maintenance Prop

C - Lip Maintenance Prop
D - Platform Header

E - Safety Leg Pull Chain
F - Lock Out Device

G - Tag Out Device

! DANGER

It is recommended and good safety practice to use an additional means to support the dock platform and lip anytime when physically working in front of or under the dock leveler. This additional means may include, but is not limited to a boom truck, fork truck, stabilizing bar or equivalent.

Whenever maintenance is to be performed under the dock leveler platform, support the platform with maintenance prop (B). Position the maintenance prop behind front header plate (D) while staying clear of the lip. Lock the maintenance prop in the service (upright) position using an OSHA approved lockout device* (F) and tag out device* (G). See Figures 24 and 25.

! WARNING

Always post safety warnings and barricade the work area at dock level and ground level to prevent unauthorized use of the unit before maintenance is complete.

Only the person servicing the equipment should have the capability to remove the lockout devices. The tag out devices* must inform that repairs are in process and clearly state who is responsible for the lockout condition.

! WARNING

A hard hat or other applicable head protection should always be worn when working under or around a dock leveler.

Always stand clear of platform lip when working in front of the dock leveler.

* Refer to OSHA regulations 1910.146. Confined Space and 1910.147. Lockout/Tagout

Periodic Maintenance

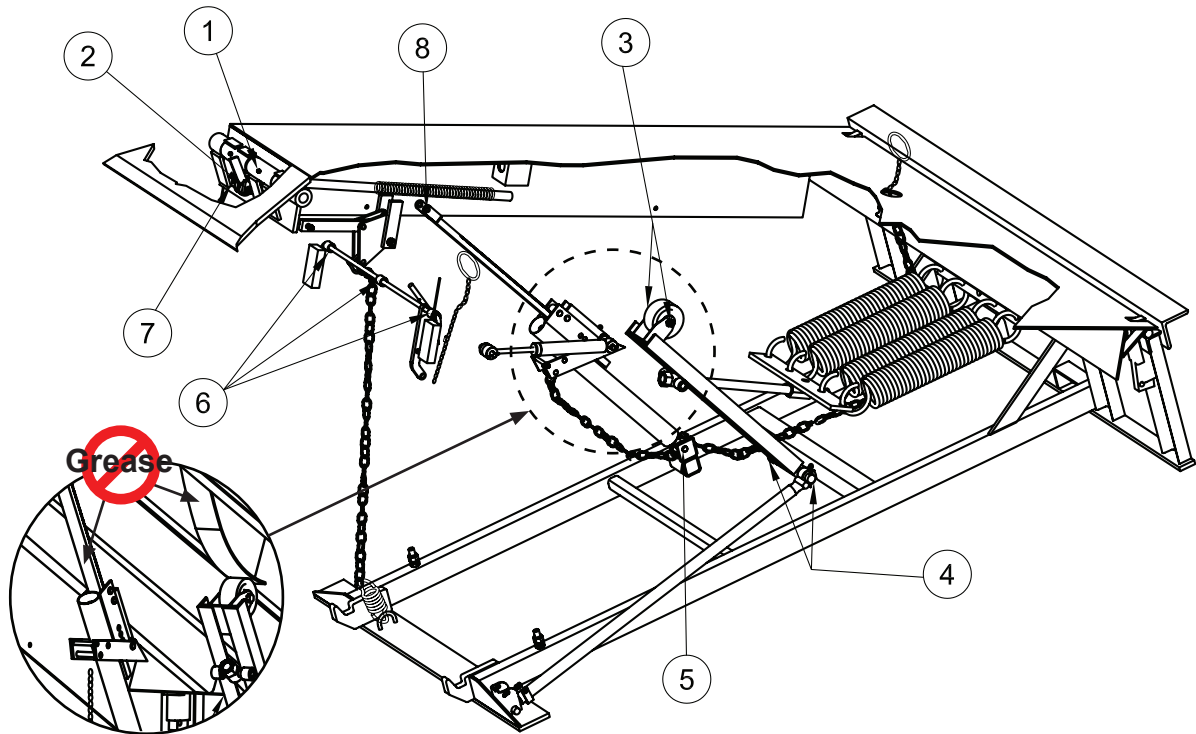

Figure 26

- 1 — Lip Hinge Grease Fittings
- 2 — Lip Maintenance Prop Pivot
- 3 — Lift Arm Roller Bushing

- 4 — Lift Arm Pivot
- 5 — Hold-Down Pivot/Pulley
- 6 — Safety Leg Linkage Pivots

- 7 — Lip Lift Assist Pin
- 8 — Hold Down-to-Platform Pin

Weekly Maintenance

- Operate the dock leveler through the complete operating cycle to maintain lubrication.

Note: To thoroughly inspect the platform hinge area, put the platform in the full below-dock position.

- Inspect the platform hinge and the lip hinge areas. The hinge areas must be kept free of dirt and debris. Build-up of foreign material in the hinge areas will cause abnormal operation.
- Inspect warning decals and placards. Replace if damaged or missing.

- Lubricate the following areas with light weight machine oil (see Figure 26):

- (2) — Lip maintenance prop pivot
- (5) — Hold-down pivot/pulley
- (6) — Safety leg linkage pivots
- (8) — Hold-down to platform pin

- Lubricate the following areas with white lithium grease:

- (1) — Lip hinge area
- (3) — Lift arm roller bushing
- (4) — Lift arm pivot
- (7) — Lip assist pin

Quarterly Maintenance

- Complete Weekly Maintenance.
- Inspect the following for damage/abnormal wear:
 - Check welds for cracks.
 - Lift arm pins and mounting holes.
 - Lip hinge pins and rear hinge pins.
 - Check toe guards for free movement.
 - Bumpers for more than 1" of wear. Replace worn, loose, damaged or missing bumpers.
 - Side and rear weather seals.

Note: Apply grease to lip hinge grease fittings if equipped. **Do not put grease or oil on the ratchet bar or cam!**

NOTICE

Failure to properly lubricate the dock leveler will cause abnormal operation of the leveler.

ADJUSTMENTS

Adjust Main Spring & Lip Assist Spring Tension

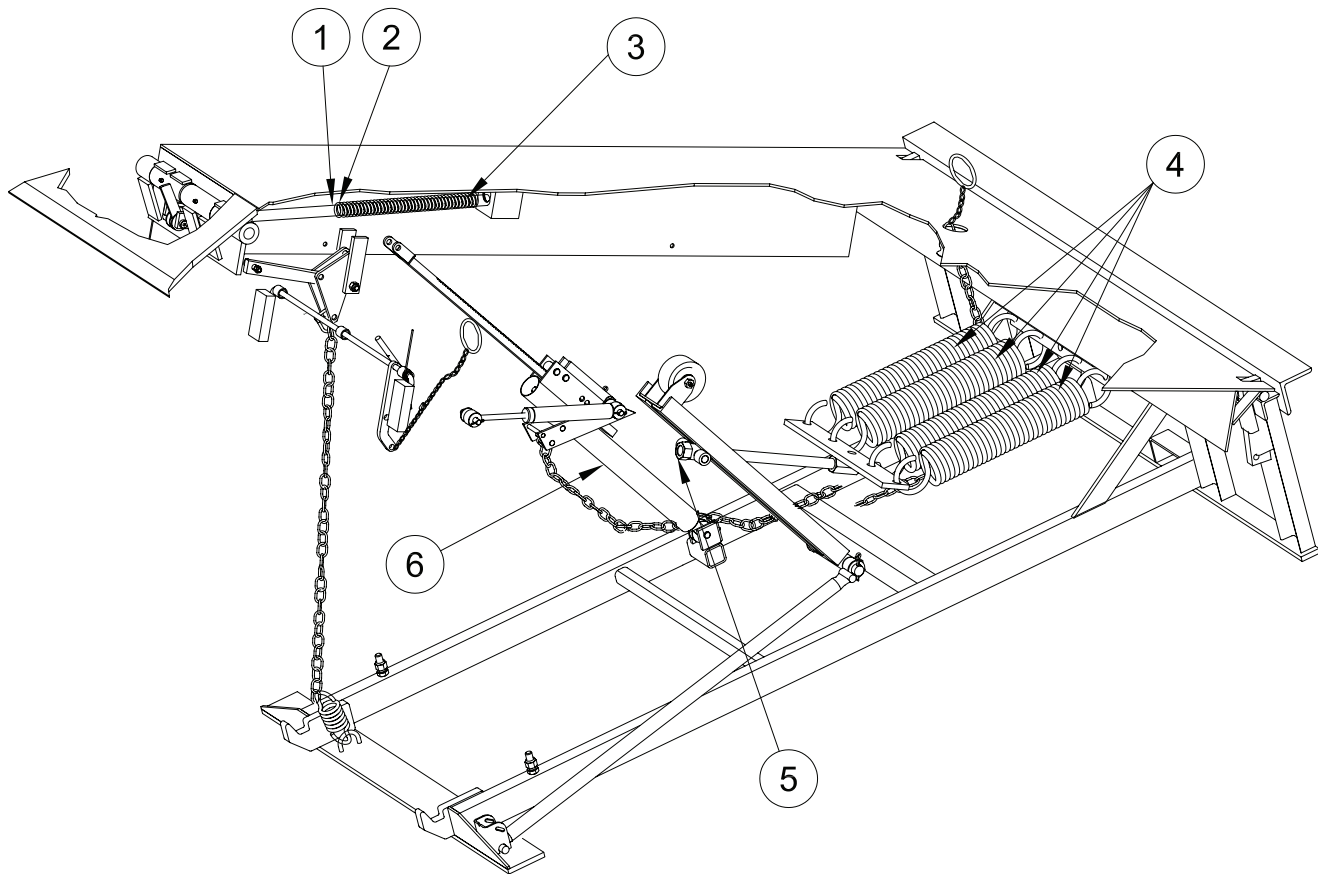

Figure 27

1 — Jam Nut
2 — Adjustable Nut

3 — Lip Assist Spring
4 — Lift Springs

5 — Lift Spring Bolt
6 — Hold-Down Mechanism

DANGER

It is recommended and good safety practice to use an additional means to support the dock platform and lip anytime when physically working in front of or under the dock leveler. This additional means may include, but is not limited to a boom truck, fork truck, stabilizing bar or equivalent.

WARNING

The maintenance prop **MUST** be in the service position when working under the dock leveler. For maximum protection, use an OSHA approved locking device to lock the maintenance prop in the service position. Only the person servicing the equipment should have the key to unlock the maintenance prop.

WARNING

Always post safety warnings and barricade the work area at dock level and ground level to prevent unauthorized use of the dock leveler before maintenance is complete.

A hard hat or other applicable head protection should always be worn when working under or around a dock leveler.

Always stand clear of platform lip when working in front of the dock leveler.

Adjust Main Spring & Lip Assist Spring Tension (continued)

WARNING

If the platform does not rise fully on its own, it may be necessary to use an external lifting device. Use a lifting device with the appropriate lifting capacity to safely raise the platform. Make sure to engage and pin the platform maintenance prop after raising the platform.

NOTICE

When using an external lifting device to raise the platform, make sure hold-down mechanism (6) is disengaged. Pull and hold platform release ring during the lifting process to avoid shearing the ratchet pawl and ratchet bar teeth.

If the platform does not rise fully and/or lip does not extend fully, the main lift spring tension may be set too low.

If the platform cannot be walked down or is difficult to walk down, the main lift spring tension may be set too high.

Note: Adjusting the tension of lift springs (4) usually requires that the lip assist spring (3) also be adjusted.

1. Raise the platform and engage the platform maintenance prop. Pin the maintenance prop in the service position using attached pin device.

2. Adjust tension of lift springs (4) as follows:

Note: Use 1/2 turn increments when adjusting lift spring bolt (5). Turn clockwise to increase tension and counterclockwise to decrease tension. Check platform operation after each adjustment. Repeat until proper operation is obtained.

- To increase lift spring tension, turn lift spring bolt (5) clockwise.
- To decrease lift spring tension, turn lift spring bolt (5) counterclockwise.

3. After lift spring adjustment is completed, check operation of the lip:

- If the lip folds before the platform can be walked down, tension of lip assist spring (3) may be set too low.
- If the lip does not fold fully or takes too long to fold, tension of lip assist spring (3) may be set too high.

4. Adjust lip assist spring tension as follows:

Note: Use two-turn increments when adjusting lip assist spring (3). Check lip operation after each adjustment. Repeat until proper operation is obtained.

- a. Loosen jam nut (1).
- b. To increase spring compression, turn nut (2) clockwise.
- c. To decrease spring compression, turn nut (2) counterclockwise.
- d. Tighten jam nut.

5. Recheck operation of platform and lip. Readjust lift spring tension and lip assist spring tension until proper operation is obtained.

ADJUSTMENTS

Adjust Lip Stop Bolt

When at rest, lip (E) should be fully resting on the lip keepers (D) and at the lowest part of the lip keepers. If lip is not resting properly in the lip keepers, perform the following adjustment:

1. Fully raise the platform and engage the maintenance prop in the service position. Manually raise the lip and engage lip maintenance prop (not shown).
2. Loosen jam nut (B).
3. Adjust stop bolt (C) as necessary.
 - Turn stop bolt "in" (clockwise) to allow lip to fold closer to platform (A).
 - Turn stop bolt "out" (counterclockwise) to hold lip further away from platform (A).
4. Tighten jam nut (B).
5. Disengage lip maintenance prop.
6. Walk platform down to cross-traffic (stored) position.
7. Check lip position in both keepers. Repeat procedure if necessary.

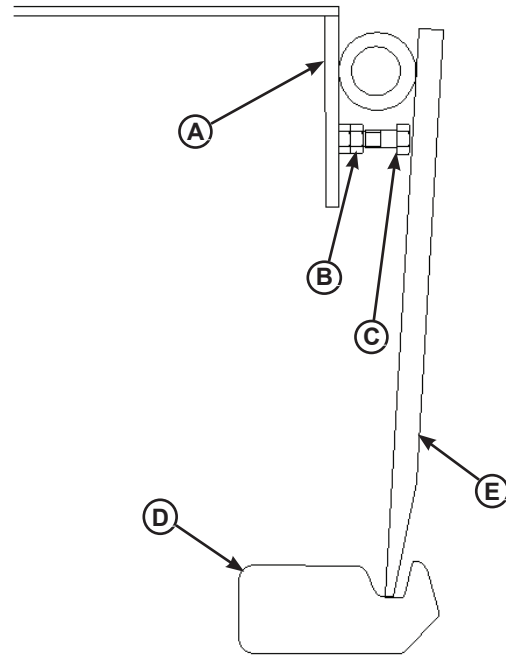

Figure 28

A— Platform
B— Jam Nut
C— Stop Bolt
D — Lip Keeper
E — Lip

This page intentionally left blank.

TROUBLESHOOTING

DANGER

It is recommended and good safety practice to use an additional means to support the dock platform and lip anytime when physically working in front of or under the dock leveler. This additional means may include, but is not limited to a boom truck, fork truck, stabilizing bar or equivalent.

WARNING

The maintenance prop **MUST** be in the service position when working under the dock leveler. For maximum protection, use an OSHA approved locking device to lock the maintenance prop in the service position. Only the person servicing the equipment should have the key to unlock the maintenance prop.

WARNING

Always post safety warnings and barricade the work area at dock level and ground level to prevent unauthorized use of the dock leveler before maintenance is complete.

A hard hat or other applicable head protection should always be worn when working under or around a dock leveler.

Always stand clear of platform lip when working in front of the dock leveler.

Symptom	Possible Cause	Solution
Platform does not rise.	Heavy object(s) on platform.	Remove object(s) from platform. Note: For safety reasons, the dock leveler is designed to lift only the platform's own weight.
	Disconnected or broken release chain.	Connect or replace release chain.
	Dock leveler binds.	Check for visible obstructions that could cause binding. Remove obstructions. If no obstructions found, contact Systems, LLC Technical Services.
Platform rises slowly or does not rise to the full raised position.	Heavy object(s) on platform.	Remove object(s) from platform. Note: For safety reasons, the dock leveler is designed to lift only the platform's own weight.
	Dock leveler binds.	Check for visible obstructions that could cause binding. Remove obstructions. If no obstructions found, contact Systems, LLC Technical Services.
	Insufficient main spring tension.	Increase tension on main springs. See pages 26-27 for instructions.
	Damaged or worn hold-down mechanism.	Inspect and clean hold-down mechanism. Replace if damaged or faulty.

TROUBLESHOOTING

Symptom	Possible Cause	Solution
Platform rises to full height, but lip does not fully extend.	Lip assist chain disconnected or broken.	Connect or replace lip assist chain.
	Insufficient main spring tension.	Increase tension on main springs. See pages 26-27 for instructions.
	Insufficient lip assist force.	Increase tension on lip assist spring. See pages 26-27 for instructions.
Platform does not lower when operator walks out onto the platform.	Excessive main spring tension.	Reduce main spring tension. See pages 26-27 for instructions.
	Damaged or worn hold-down mechanism.	Inspect and clean hold-down mechanism. Replace if damaged or faulty.
Lip folds too fast during normal walk-down.	Insufficient lip assist force.	Increase tension on lip assist spring. See pages 26-27 for instructions.
	Disconnected, worn, or broken gas shock.	Inspect gas shock. Replace if damaged or faulty.
Platform does not stay down.	Binding or stuck release chain.	Check for visible obstructions that could cause binding. Remove obstructions.
	Dirt impacted in ratchet bar teeth.	Inspect and clean ratchet bar and ratchet pawl teeth. <u>DO NOT lubricate the ratchet assembly.</u>
	Broken or damaged ratchet assembly teeth.	Replace ratchet assembly. <u>DO NOT lubricate the ratchet assembly.</u>
	Disconnected or broken hold-down pivot pins.	Connect or replace hold-down pivot pins.
	Damaged or worn hold-down mechanism.	Inspect and clean hold-down mechanism. Replace if damaged or faulty.
Lip does not fold after truck departs.	Lip hinge binding due to lack of lubrication	Grease lip hinge. See page 25 for instructions.
	Excessive lip assist force.	Decrease tension on lip assist spring. See pages 26-27 for instructions.

If additional troubleshooting assistance is required, contact Systems, LLC Technical Services with equipment serial number or customer order number (CO#).

Technical Service at 800-643-5424 or techservices@docksystemsinc.com

PARTS

Hold-Down Components

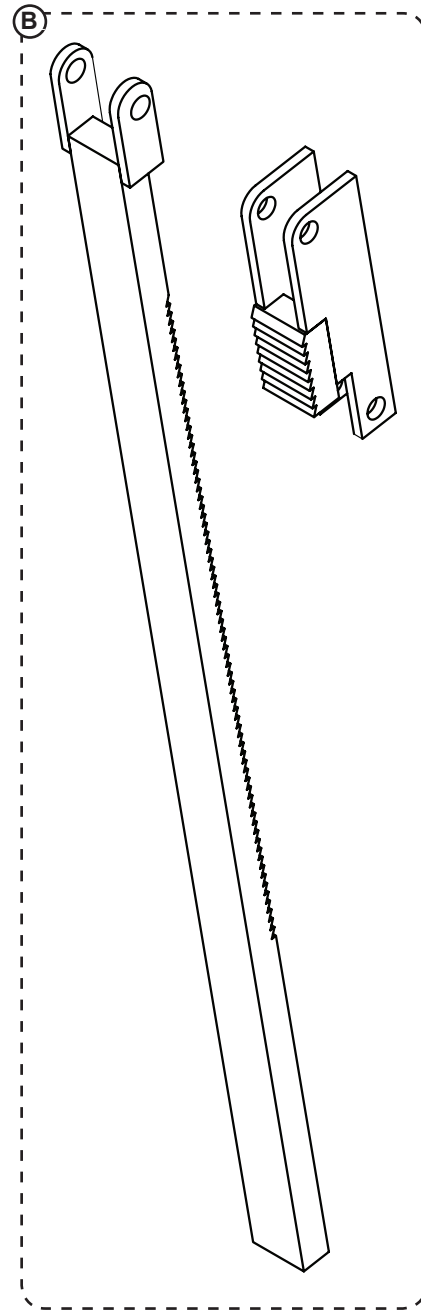
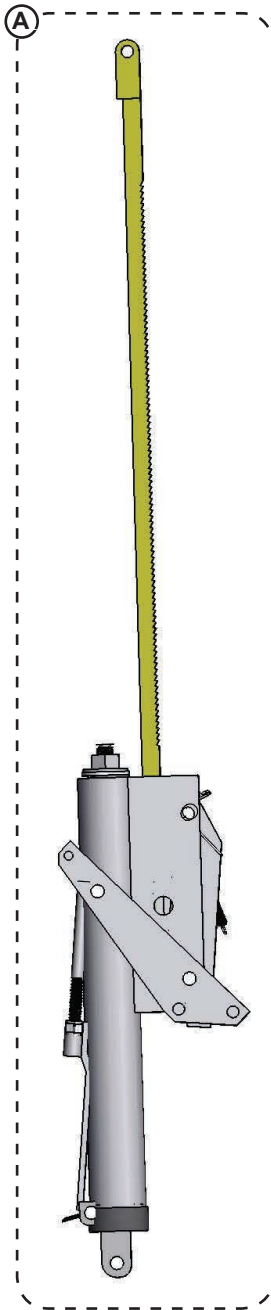

Item	Quantity	Part Number	Description
A	1	M502.089	Hold Down, Complete (fits 1990-present)
B	1	M512.986	Ratchet and Pawl Kit (for M502.089)
NS*	1	M512.988	Release Arm Spring (for M502.089)

* NS = Not Shown

Main Lift Springs

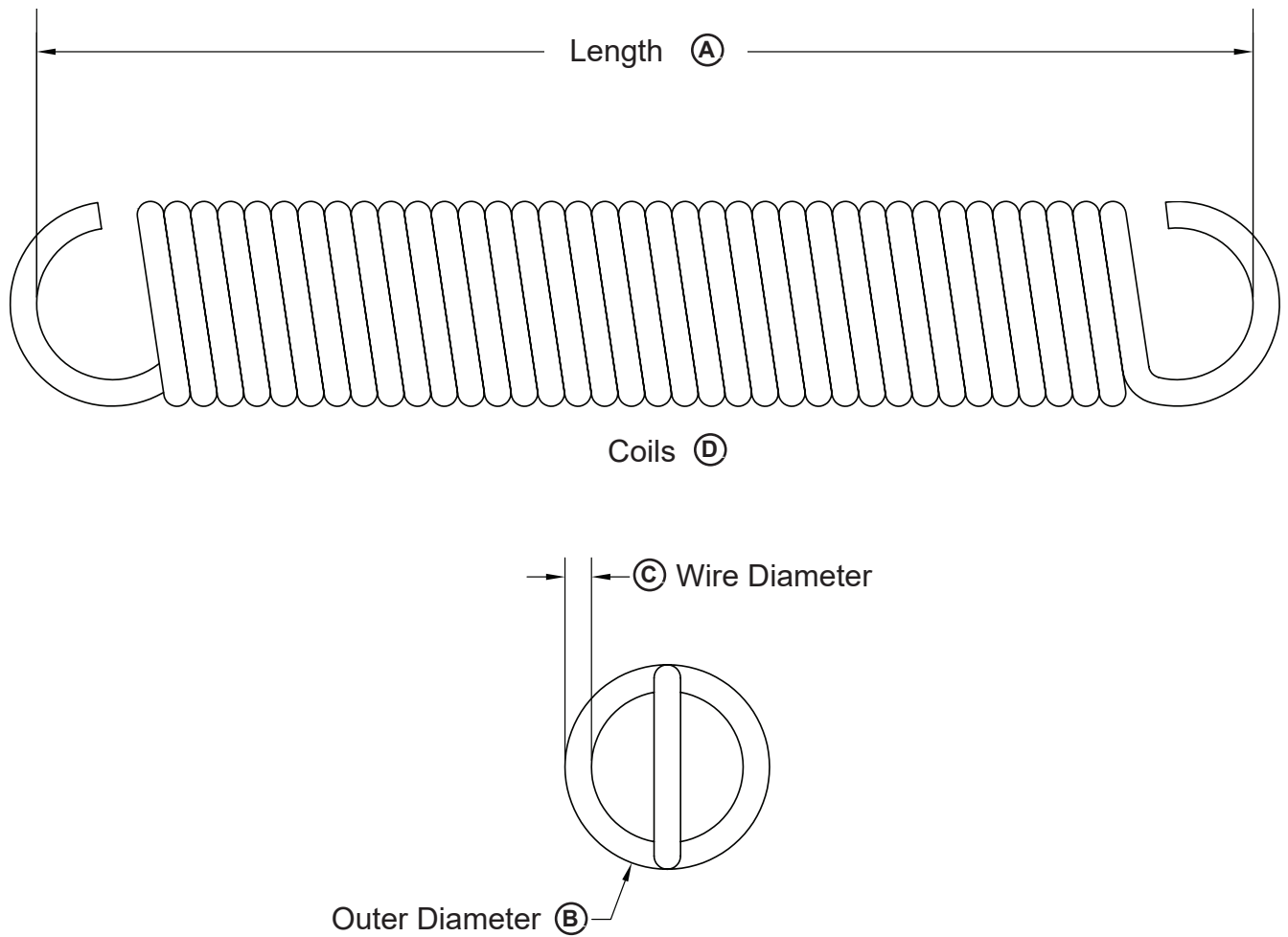

Part Number*	Description	Length (A)	O.D. (B)	Wire Dia. (C)	Coils (D)
DOTH-2570	Main Lift Spring - Blue	20" (508mm)	3.468" (88mm)	.406" (10mm)	38
DOTH-2574	Main Lift Spring - Red	21" (533mm)	4.750" (121mm)	.531" (13mm)	26
DOTH-2576	Main Lift Spring - Black	23" (584mm)	3.875" (98mm)	.500" (12mm)	37
DOTH-2578	Main Lift Spring - Yellow	23" (584mm)	4.700" (119mm)	.594" (15mm)	30

* Provide dock leveler serial number, platform size, lip size and capacity when e-mailing, calling or faxing orders.

PARTS

Frame Components

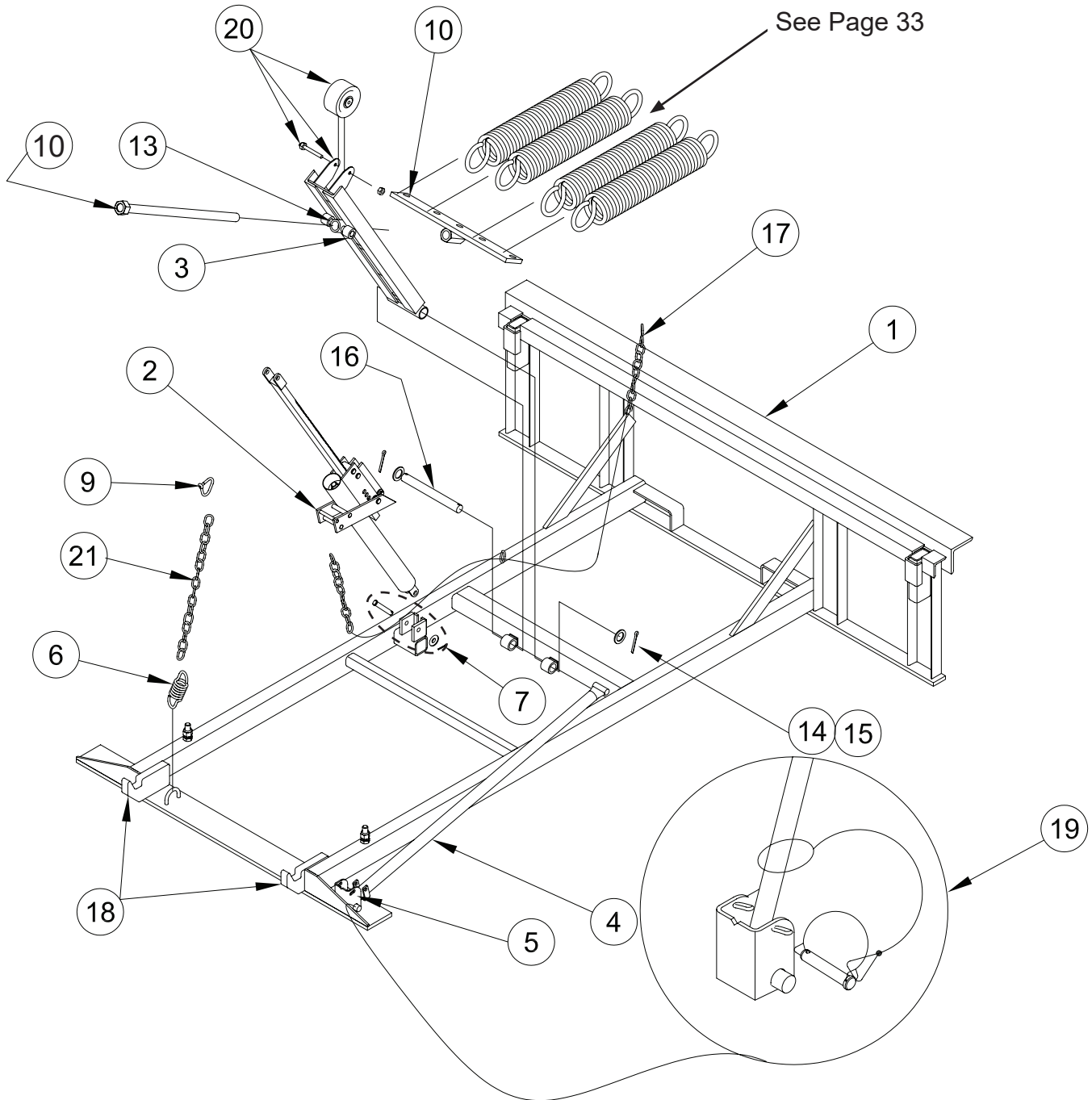

Frame Components

Item	Quantity	Part Number	Description
1	1	8435-____*	Frame, Welded Assembly
2	1	M502.089	Hold Down, Complete (fits 1990-present)
3	1	DOTP-6424*	Lift Arm, Short, 25" (Includes Caster Assembly)
	1	DOTP-6423*	Lift Arm, Long, 27" (Includes Caster Assembly)
4	1	9224-____*	Prop, Maintenance
5	1	9221-____*	Housing, Maintenance Prop
6	1	DOTH-2555	Spring, Snubber
7	1	2101-0361	Bolt, Shoulder, 1/2 x 2-1/4, 3/8-16
		DFRA-0350	Roller, Release Chain
		DOTH-2210	Washer, Flat, 1/2"
		2101-0060	Washer, Flat, 3/8" SAE
		DOTH-2131	Lock Nut, Nylon, 3/8-16
9	1	DOTH-2416	Lap Link, 3/16" x 1"
10	1	DFRA-0326*	T-Bar and Adjusting Rod, 6'
		DFRA-0327*	T-Bar and Adjusting Rod, 8'/10'
13	2	DOTH-2218	Washer, Flat, 1-1/16" ID x 2" OD
14	2	DOTH-2222	Washer, Flat, 1-1/16 ID x 1-1/2 OD
15	4	DOTH-2374	Pin, Cotter, 1/8 x 1
16	1	DFRA-1205	Pin, Lift Arm, 1" x 9-1/8"
17	1	5265-0012*	Chain, Hold-Down Release, 6'
		5265-0013*	Chain, Hold-Down Release, 8'
		5265-0014*	Chain, Hold-Down Release, 10'
18	2	8432-____*	Keeper, Lip
19	1	9201-0006	Prop Pin & Clip
20	1	DOTH-2401	Caster Assembly, 4" OD
21	1	DPLA-2128	Chain, Lip Assist Link

* Provide dock leveler serial number, platform size, lip size and capacity when e-mailing, calling or faxing orders.

PARTS

Platform Components

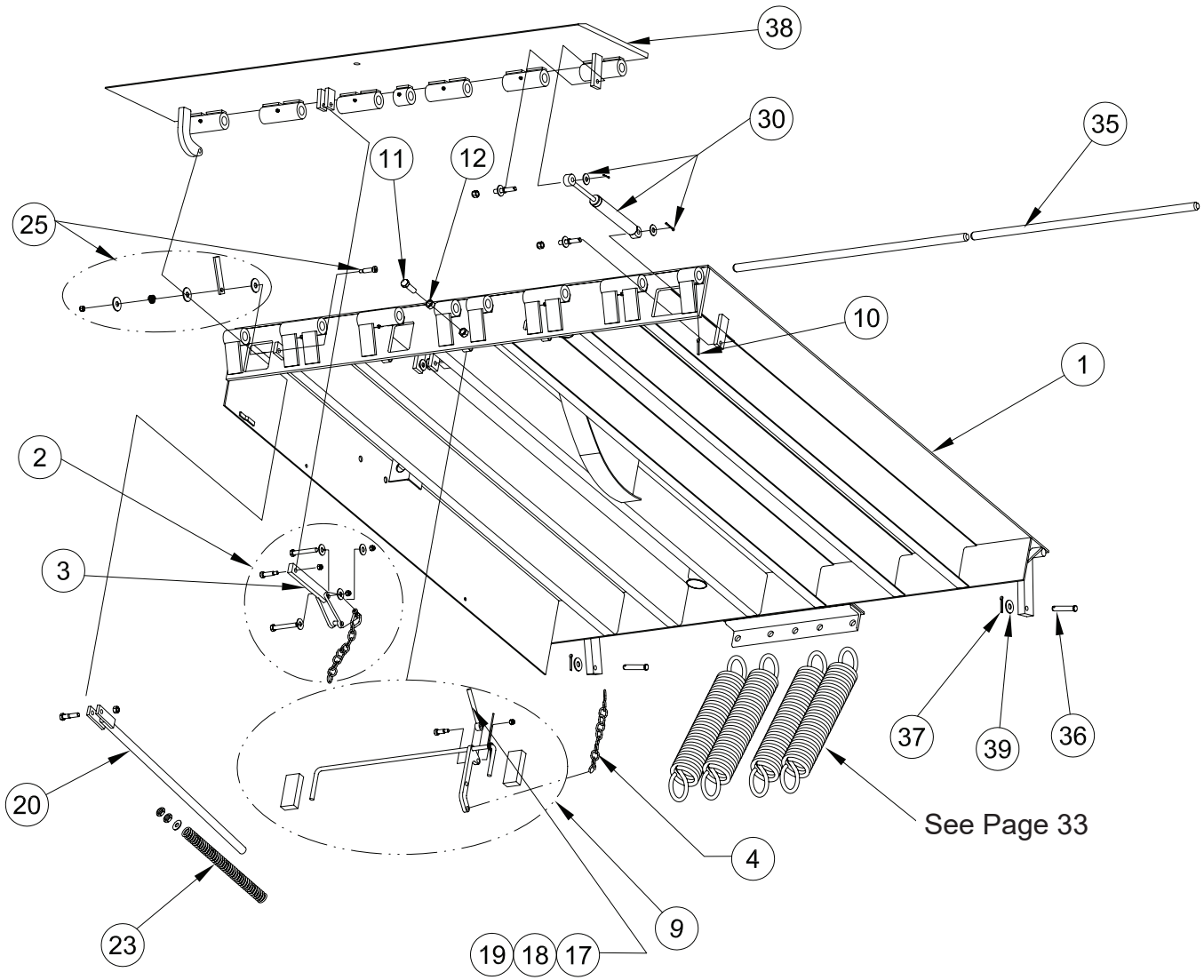

Platform Components

Item	Quantity	Part Number	Description
1	1	9515-____*	Platform, Welded Assembly
2	1	DPLA-0338	Lip Banger Assembly, Neutron (Includes Item 3)
3	1	DPLA-0341	Bar, 5/8 x 1 x 11-5/8
4	1	DPLA-0353	Below Dock Chain Assembly
9	1	DPLA-0343	Below Dock Control Assembly
		DPLA-0401	Below Dock Control Assembly (6' Long Units Only)
10	2	DOTH-2382	Pin, Cotter, 1/4 x 2
11	1	DOTH-2074	Bolt, Hex, 5/8-11 UNC x 2
12	1	DOTH-2160	Nut, Hex, 5/8-11
17	1	DPLA-0360	Below Dock Control Push Rod Assembly
18	1	DOTH-2060	Bolt, Shoulder, 1/2 x 1, 3/8"-16 UNC
19	1	DOTH-2131	Lock Nut, Nylon, 3/8-16
20	1	DOTH-6406	Lip Assist Rod
23	1	DOTH-2550*	Spring, Lip Assist, Standard Orange)
		DOTH-2546*	Spring, Lip Assist, Heavy Duty (Green)
25	1	9513-0091	Assembly, Lip Prop
30	1	DKIT-6465	Kit, Gas Shock w/Hardware
35	2	DPLA-2101*	Pin, Lip Hinge, 1" OD x 35.25
		DPLA-2102*	Pin, Lip Hinge, 1" OD x 38.25
		DPLA-2103*	Pin, Lip Hinge, 1" OD x 40.5
36	2	DOTH-2355	Pin, Clevis, 1/2 x 2-1/4 w/Hole
37	2	DOTH-2373	Cotter Pin, 1/8 x 1-1/2
38	1	0595-____*	Lip, Welded Assembly
39	2	2101-0079	Washer, Flat, 1/2" SAE

* Provide dock leveler serial number, platform size, lip size and capacity when e-mailing, calling or faxing orders.

PARTS

Weather Seals

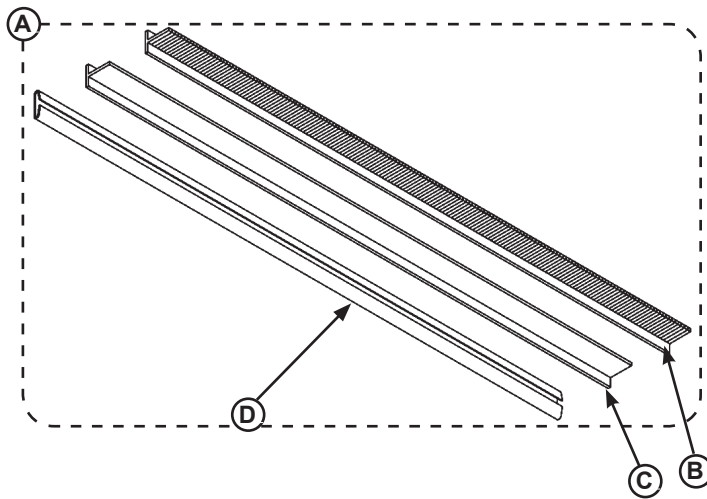

Weather Seal Kits

Item	Quantity	Part Number	Description
A	1	DKIT-9293	Brush Kit (Includes Seal and Track), 1-1/2 in. 84" Lg. (Both Sides)
	1	DKIT-9292	Rubber Kit (Includes Seal and Track), 1-1/2 in. 84" Lg. (Both Sides)

Individual Replacement Seals

Item	Quantity	Part Number	Description
B	1	DOTH-2822	Brush Refill, 1-1/2 in. 84" Lg.
C	1	DOTH-2824	Rubber Refill, 1-1/2 in. 84" Lg.
D	1	DOTH-2840	Replacement Channel

Toe Guards

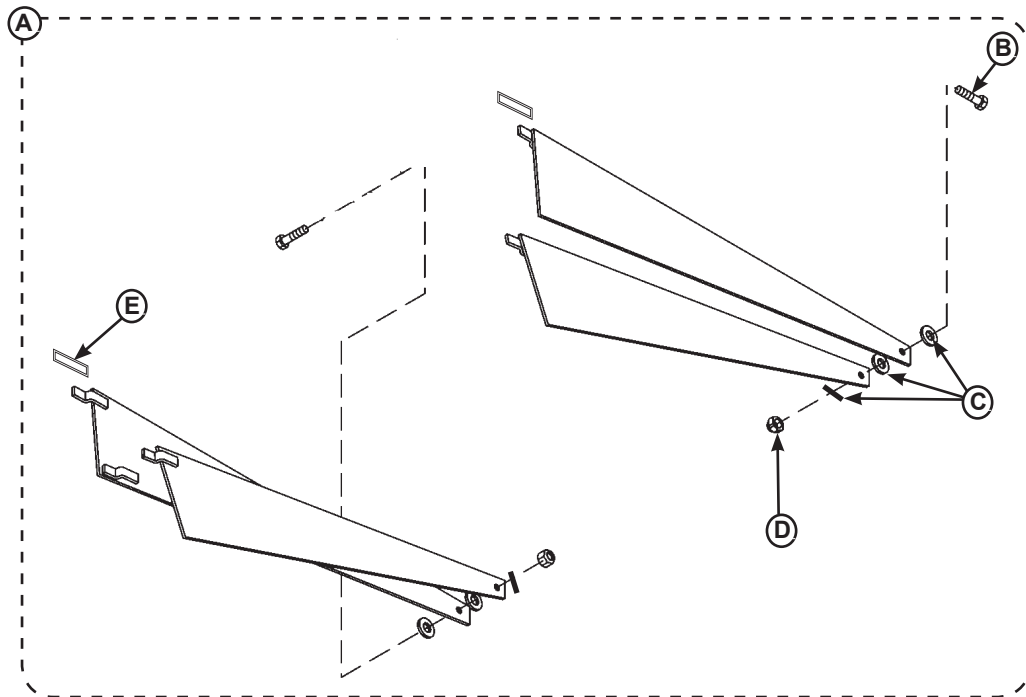

Item	Quantity	Part Number	Description
A	1	DKIT-9183*	Toe Guard Kit, Sliding 6' (Includes Both Sides)
		DKIT-9184*	Toe Guard Kit, Sliding 8' (Includes Both Sides)
		DKIT-9185*	Toe Guard Kit, Sliding 10' (Includes Both Sides)
B	2	DOTH-2043	Cap Screw
C	6	DOTH-2207	Washer
D	2	DOTH-2131	Lock Nut
E	2	0011-0010	Platform Mounting Tab

* Provide dock leveler serial number and size of platform when e-mailing, calling or faxing orders.

MISCELLANEOUS

This page intentionally left blank.

Customer Information

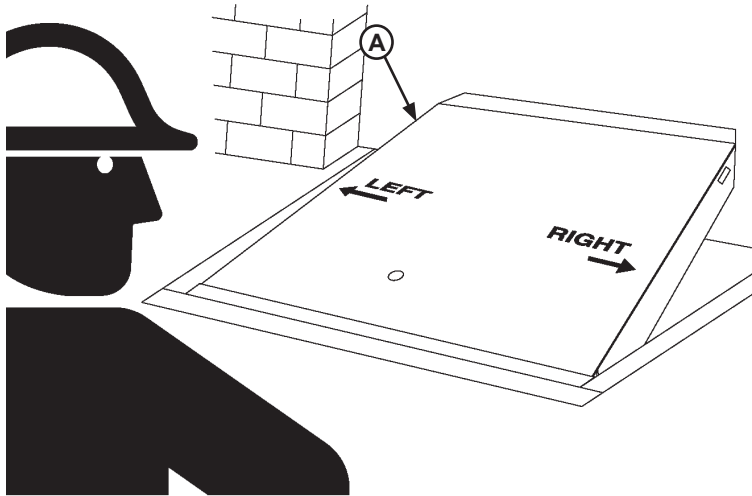

Figure 29

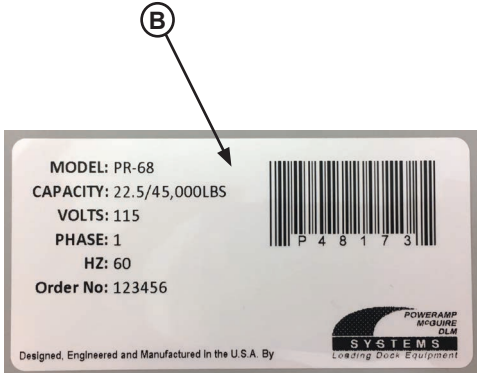

Figure 30

NOTE: Refer to Figure 29 for left/right orientation of dock leveler and Figure 30 for example of decal.

The LEVELER model/serial number decal is located on the left platform joist near the front (lip) of dock leveler (A).

When you receive your new equipment, write down the model and serial number in the form provided. This will help ensure safe keeping of the numbers in the event the model/serial number decal (A, B) becomes lost or damaged.

Also, write down Systems, LLC's order number, the company that installed the dock leveler, and the original owner's name. This will all help to identify the specific dock leveler if more information is required.

When ordering, use part numbers and description to help identify the item ordered. Do not use "item" numbers. These are only for locating the position of the parts. Always give dock leveler MODEL NUMBER and/or SERIAL NUMBER.

For service, call or contact:

Systems, LLC
P.O. Box 309
Germantown, WI 53022

Phone: (800) 643-5424
Fax: (262) 255-5917

www.loadingdocksystems.com

Form with sections: Dock Leveler Information, Vehicle Restraint Information, Original Owner Information, Installer Information. Includes fields for Model, Serial No., Systems, LLC Job No., Name, Address, and Date of Installation.

STANDARD PRODUCT WARRANTY

SYSTEMS, LLC warrants that its products will be free from defects in design, materials and workmanship for a period of one (1) year from the date of shipment. All claims for breach of this warranty must be made within 30 days after the defect is or can with reasonable care, be detected. In no event shall any claim be made more than 30 days after this warranty has expired. In order to be entitled to the benefits of this warranty, the product must have been properly installed, maintained and operated in accordance with all manufacturer's recommendations and/or specified design parameters and not otherwise have been subject to abuse, misuse, misapplication, acts of nature, overloading, unauthorized repair or modification, application in a corrosive environment or lack of maintenance. Periodic lubrication, adjustment and inspection in accordance with all manufacturers' recommendations are the sole responsibility of the Owner/User.

In the event of a defect, as determined by SYSTEMS LLC, covered by this warranty, SYSTEMS LLC shall remedy such defect by repairing or replacing any defective equipment or parts, bearing the cost for the parts, labor and transportation. This shall be exclusive remedy for all claims whether based on contract, negligence or strict liability.

WARRANTY LIMITATIONS

THE ABOVE WARRANTIES ARE IN LIEU OF ANY OTHER WARRANTIES, WHETHER EXPRESSED OR IMPLIED, INCLUDING BUT NOT LIMITED TO ANY IMPLIED WARRANTY OF MERCHANTABILITY OR FITNESS FOR A PARTICULAR PURPOSE. SYSTEMS LLC AND ITS SUBSIDIARIES SHALL NOT IN ANY EVENT BE LIABLE TO ANYONE, INCLUDING THIRD PARTIES, FOR INCIDENTAL, CONSEQUENTIAL OR SPECIAL DAMAGES OF ANY KIND INCLUDING BUT NOT LIMITED TO, BREACH OF WARRANTY, LOSS OF USE, LOSS OF PROFIT, INTERRUPTION OF BUSINESS OR LOSS OF GOODWILL.

PRODUCT SPECIFIC WARRANTY "MP" SERIES LEVELER

In addition to the "Standard Product Warranty" provided with all McGuire® products, Systems LLC, guarantees materials, components and workmanship to be free of defects for the following extended periods:

- Structural Warranty – For an additional period of four (4) years, for parts, labor and freight, product will carry a **prorated** structural warranty. This warranty specifically applies to; the deck section, lip section, frame, rear hinge assembly and front hinge assembly only. This warranty covers structural repairs to or replacement of dock leveler in Systems LLC sole discretion and expense including reasonable labor, materials, freight and travel. If Systems LLC determines replacement is necessary, it will provide the original purchaser with a credit toward the purchase of the new replacement Systems LLC product in the amount equal to the original purchase price of the warranted product F.O.B. point of manufacture, discounted on a five year straight line basis by the number of years of use prior to replacement.