



A Division of Systems, LLC

Bar Lift

Safety Barrier

Owner's/User's Manual



McGuire • Division of Systems, LLC • W194 N11481 McCormick Drive • Germantown, WI 53022
800.624.8473 • fax: 262.255.5917 • www.wbmcguire.com • techservices@loadingdocksystems.com

Printed in U.S.A.
© 2020 Systems, LLC - All Rights Reserved

Manual No. 4111-0091
Apr. 2020

Table of Contents

	Page
Precautions	
Recognize Precautionary Information	1
General Operational Precautions	1
Operational Precautions	2
Safety Decals.....	4
Placard	5
Owner's/User's Responsibilities.....	6
Introduction	
General Information.....	8
Component Identification.....	9
Installation	
Installation Precautions	10
Installation	11
Install Control Panel and Wiring	12
Put New Barrier Into Service	13
Operation	
Operational Precautions	14
Operating Instructions	15
Maintenance	
Maintenance Precautions.....	16
Periodic Maintenance	18
Adjustments	
Adjust Main Pressure Relief	20
Adjust Flow Control.....	21
Troubleshooting	
Troubleshooting.....	22
Parts	
Barrier Arm & Receiver	26
Base Assembly	28
Powerpack Assembly	30
Cylinder Assembly.....	32
Valve Assembly.....	34
Solenoid Coil & Harness	36
Miscellaneous	
Customer Information	37
Warranty.....	Back Cover

Recognize Precautionary Information

Safety-Alert Symbol



The Safety-Alert Symbol is a graphic representation intended to convey a safety message without the use of words. When you see this symbol, be alert to the possibility of death or serious injury. Follow the instructions in the safety message panel.

DANGER

The use of the word DANGER signifies the presence of an extreme hazard or unsafe practice which will most likely result in death or severe injury.

WARNING

The use of the word WARNING signifies the presence of a serious hazard or unsafe practice which could result in death or serious injury.

CAUTION

The use of the word CAUTION signifies possible hazard or unsafe practice which could result in minor or moderate injury.

NOTICE

The use of the word NOTICE indicates information considered important, but not hazard-related, to prevent machine or property damage.

SAFETY INSTRUCTIONS

Indicates a type of safety sign, or separate panel on a safety sign, where safety-related instructions or procedures are described.

General Operational Precautions



Read and understand the Owner's/User's Manual and become thoroughly familiar with the equipment and its controls before operating the dock leveler.

Never operate a dock leveler while a safety device or guard is removed or disconnected.

Never remove DANGER, WARNING, or CAUTION signs, Placards or Decals on the equipment unless replacing them.

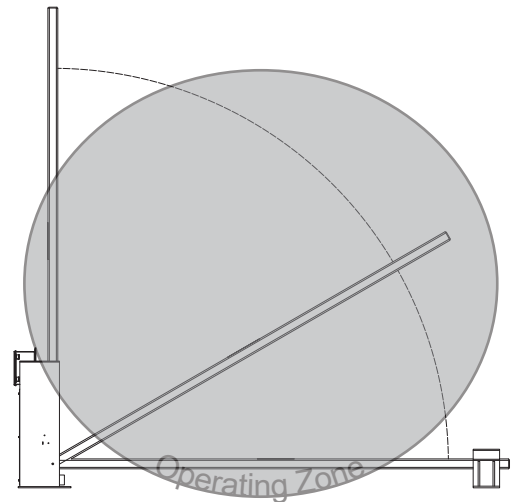

Figure 1

Do not start the equipment until all unauthorized personnel in the area have been warned and have moved outside the operating zone (see Figure 1).

Remove any tools or foreign objects from the operating zone before starting.

Keep the operating zone free of obstacles that could cause a person to trip or fall.



WARNING: This product can expose you to chemicals including lead, which are known to the State of California to cause cancer or birth defects or other reproductive harm. For more information go to www.P65Warnings.ca.gov

PRECAUTIONS

Operational Precautions



Learn the safe way to operate this equipment. Read and understand the manufacturer's instructions. If you have any questions, ask your supervisor.

DANGER



Stay clear of dock leveling device when transport vehicle is entering or leaving area.



Do not move or use the dock leveling device if anyone is under or in front of it.

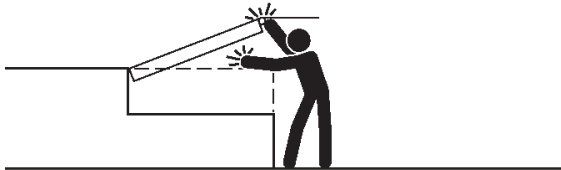

Keep hands and feet clear of pinch points. Avoid putting any part of your body near moving parts.

WARNING



Chock/restrain all transport vehicles. Never remove the wheel chocks or release the restraining device until loading or unloading is finished, and transport driver has been given permission to drive away.



Do not use a broken or damaged dock leveling device or restraining device. Make sure proper service and maintenance procedures have been performed before using.



Make sure lip overlaps onto transport vehicle bed at least 4 in. (102 mm).



Keep a safe distance from both side edges.

Operational Precautions

! WARNING

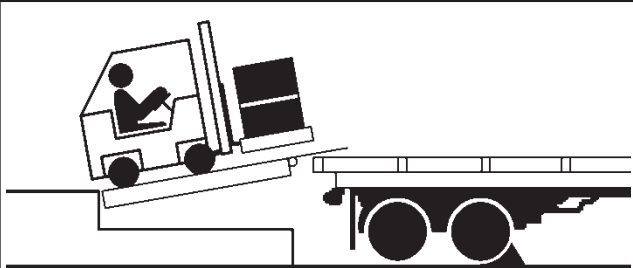

Do not use dock leveling device if transport vehicle is too high or too low.

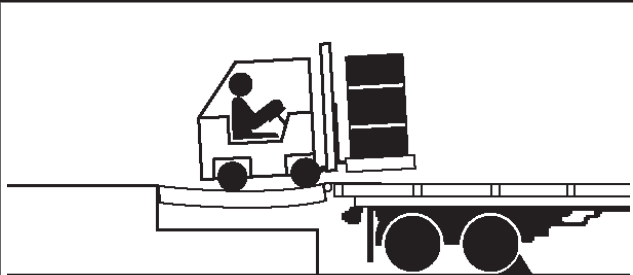

Do not overload the dock leveling device.



Do not operate any equipment while under the influence of alcohol or drugs.

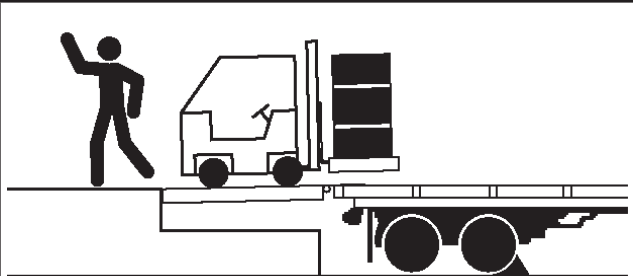

Do not leave equipment or material unattended on dock leveling device.

PRECAUTIONS

Safety Decals

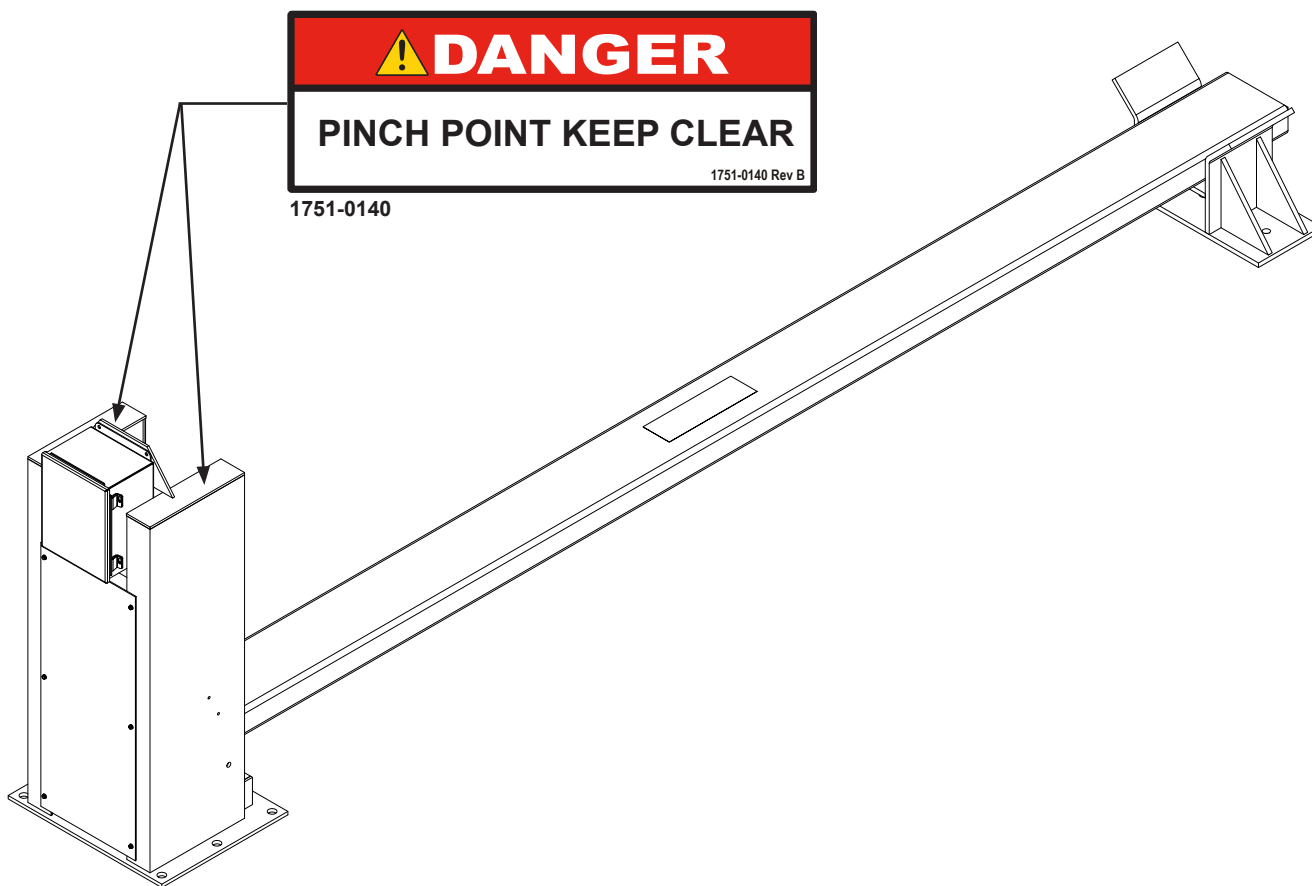

Safety Decals



1751-0329



1751-0330 Two positions one on top of each fork pocket.

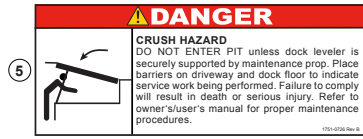

1751-0726

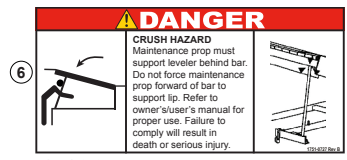

1751-0727



1751-0729

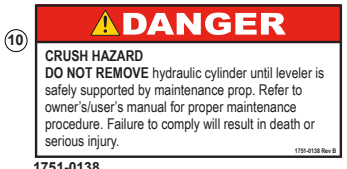

1751-0138

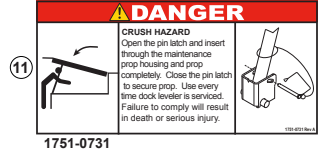

1751-0731



1751-0735

4 DANGER

Unsupported dock leveler ramps can lower unexpectedly.

Before allowing vehicle to leave the dock always:

- Ensure no equipment, material or people are on dock leveler.
- Return dock leveler to its stored position at dock level.

Failure to follow posted instructions will result in death or serious injury.

SAFETY INFORMATION

PRESENCE

1. Read and follow all instructions and warnings on the user's manual.
2. Use of dock leveler restricted to trained operators.
3. Always check trailer wheels on engage truck restraint before opening dock leveler or beginning load or unload.
4. Never use ramps or equipment to move ramp or lip.
5. Rollback and locking dock leveler.
6. Rollback and locking dock leveler.
7. Rollback and locking dock leveler.
8. Rollback and locking dock leveler.
9. Rollback and locking dock leveler.
10. Rollback and locking dock leveler.
11. Rollback and locking dock leveler.

MAINTENANCE/SERVICE

Read and follow all instructions, warnings and maintenance schedules in the owner's manual.

1. Maintenance/service of dock leveler restricted to trained personnel.

2. Place barriers on the driveway and dock floor to restrict service work to being performed.

3. DO NOT ENTER. Do not allow dock leveler to be lowered unless dock leveler is securely supported by maintenance prop.

4. Electrically powered form of and use OSHA's lockout/tagout procedures.

5. Electrically powered form of and use OSHA's lockout/tagout procedures.

4 DANGER

Unsupported dock leveler ramps can lower unexpectedly.

Before allowing vehicle to leave the dock always:

- Ensure no equipment, material or people are on dock leveler.
- Return dock leveler to its stored position at dock level.

Failure to follow posted instructions will result in death or serious injury.

SAFETY INFORMATION

PRESENCE

1. Read and follow all instructions and warnings on the user's manual.
2. Use of dock leveler restricted to trained operators.
3. Always check trailer wheels on engage truck restraint before opening dock leveler or beginning load or unload.
4. Never use ramps or equipment to move ramp or lip.
5. Rollback and locking dock leveler.
6. Rollback and locking dock leveler.
7. Rollback and locking dock leveler.
8. Rollback and locking dock leveler.
9. Rollback and locking dock leveler.
10. Rollback and locking dock leveler.
11. Rollback and locking dock leveler.

MAINTENANCE/SERVICE

Read and follow all instructions, warnings and maintenance schedules in the owner's manual.

1. Maintenance/service of dock leveler restricted to trained personnel.

2. Place barriers on the driveway and dock floor to restrict service work to being performed.

3. DO NOT ENTER. Do not allow dock leveler to be lowered unless dock leveler is securely supported by maintenance prop.

4. Electrically powered form of and use OSHA's lockout/tagout procedures.

5. Electrically powered form of and use OSHA's lockout/tagout procedures.

1751-0730

A Division of Systems, LLC

1.800.643.5496

POWERAMP

Premium Loading Dock Systems

www.Poweramp.com

A Division of Systems, LLC

1.800.643.5424

POWERAMP

Premium Loading Dock Systems

www.Poweramp.com

1751-0397

A Division of Systems, LLC

1.800.643.5424

POWERAMP

PR Series

www.Poweramp.com

1751-0406

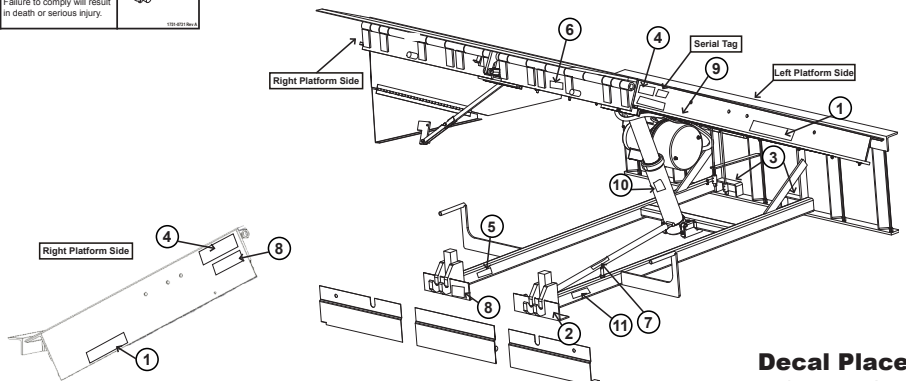

Decal Placement for PR Series

OWNER'S/USER'S RESPONSIBILITIES

- 1) The manufacturer shall provide to the initial purchaser and make the following information readily available to the owners/users and their agents, all necessary information regarding Safety Information, Operation, Installation and Safety Precautions, Recommended Initial and Periodic Inspections Procedures, Planned Maintenance Schedule, Product Specifications, Troubleshooting Guide, Parts Break Down, Warranty Information, and Manufacturers Contact Information, as well as tables to identify the grade(slope) for all variations of length or configuration of the dock leveling device and information identifying the maximum uncontrolled drop encountered when sudden removal of support while in the working range of the equipment.
- 2) When selecting loading dock safety equipment, it is important to consider not only present requirements but also future plans and any possible adverse conditions, environmental factors or usage. The owners/users shall provide application information to the manufacturer to receive recommendations on appropriate equipment specifications and capacity.
- 3) The owner/user must see all nameplates, placards, decals, instructions and posted warnings are in place and legible and shall not be obscured from the view of the operator or maintenance personnel for whom such warnings are intended for. Contact manufacturer for any replacements.
- 4) Dock leveling devices may become hazardous if the manufacturer's instructions regarding modifications or adjustments are not followed. Modifications or alterations of dock leveling devices shall only be made with prior written approval from the original manufacturer. These changes shall be in conformance with all applicable provisions of the MH30.1 standard and shall also satisfy all safety recommendations of the original equipment manufacturer of the particular application.
- 5) The owner/user should recognize the inherent dangers of the interface between the loading dock and the transport vehicle. The owner/ user should, therefore, train and instruct all operators in the safe operation and use of the loading dock equipment in accordance with manufacturer's recommendations and industry standards. Effective operator training should also focus on the owner's/user's company policies, operating conditions and the manufacturer's specific instructions provided with the dock leveling device. Maintaining, updating and retraining all operators on safe working habits and operation of the equipment, regardless of previous experience, should be done on a regular basis and should include an understanding and familiarity with all functions of the equipment. Owners/users shall actively maintain, update and retrain all operators on safe working habits and operations of the equipment.
- 6) An operator training program should consist of, but not necessarily be limited to, the following:
 - a) Select the operator carefully. Consider the physical qualifications, job attitude and aptitude.
 - b) Assure that the operator reads and fully understands the complete manufacturer's owners/users manual.
 - c) Emphasize the impact of proper operation upon the operator, other personnel, material being handled, and equipment. Cite all rules and why they are formulated.
 - d) Describe the basic fundamentals of the dock leveling device and components design as related to safety, e.g., mechanical limitation, stability, functionality, etc.
 - e) Introduce the equipment. Show the control locations and demonstrate its functions. Explain how they work when used properly and maintained as well as problems when they are used improperly.
 - f) Assure that the operator understands the capacity rating, nameplate data, placards and all precautionary information appearing on the dock leveling device.
 - g) Supervise operator practice of equipment.
 - h) Develop and administer written and practical performance tests. Evaluate progress during and at completion of the course.
 - i) Administer periodic refresher courses. These may be condensed versions of the primary course and include on-the-job operator evaluation.

OWNER'S/USER'S RESPONSIBILITIES

- 7) Loading dock safety equipment should never be used outside of its vertical working range, or outside the manufacturer's rated capacity. It shall also be compatible with the loading equipment and other conditions related to dock activity. Please consult the manufacturer if you have any questions as to the use, vertical working range or capacity of the equipment. Only properly trained and authorized personnel should operate the equipment.
- 8) It is recommended that the transport vehicle is positioned as close as practical to the dock leveling device and in contact with both bumpers. When an industrial vehicle is driven on or off a transport vehicle during loading and unloading operations, the transport vehicle parking brakes shall be applied and wheel chocks or a restraining device that provides equal or better protection of wheel chocks shall be engaged. Also, whenever possible, air-ride suspension systems should have the air exhausted prior to performing said loading and unloading operations.
- 9) When goods are transferred between the loading dock and a trailer resting on its support legs/ landing gear instead of a tractor fifth wheel or converter dolly, it is recommended that an adequate stabilizing device or devices shall be utilized at the front of the trailer.
- 10) In order to be entitled to the benefits of the standard product warranty, the dock safety equipment must have been properly installed, maintained and operated in accordance with all manufacturer's recommendations and/ or specified design parameters and not otherwise have been subject to abuse, misuse, misapplication, acts of nature, overloading, unauthorized repair or modification, application in a corrosive environment or lack of maintenance. Periodic lubrication, adjustment and inspection in accordance with all manufacturers' recommendations are the sole responsibility of the owner/user.
- 11) Manufacturer's recommended maintenance and inspection of all dock leveling devices shall be performed in conformance with the following practices: A planned maintenance schedule program must be followed, only trained and authorized personnel shall be permitted to maintain, repair, adjust and inspect dock leveling devices, and only the use of original equipment manufacturer parts, manuals, maintenance instructions, labels, decals and placards or their equivalent. Written documentation of maintenance, replacement parts or damage should be kept. In the event of damage, notification to the manufacturer is required.
- 12) Loading dock devices that are structurally damaged or have experienced a sudden loss of support while under load, such as might occur when a transport vehicle is pulled out from under the dock leveling device, shall be removed from service, inspected by a manufacturer's authorized representative, and repaired or replaced as needed or recommended by the manufacturer before being placed back in service.

INTRODUCTION

General Information



Figure 3

This manual provides current information on the Bar Lift Safety Barrier. Due to ongoing product improvement, some parts may have changed, along with operation and troubleshooting methods. This manual describes these changes where applicable.

The McGuire Bar Lift Barrier adds enhanced safety to any loading dock by preventing forklift trucks from accidentally driving off the edge of the dock. The Bar Lift Barrier also protects the overhead door from forklift truck collisions.

The barrier bar that spans across the door opening is constructed from a 3" x 8" tube with 3/8" thick walls made from A500 steel. The barrier housing and receiver assembly are mounted into the concrete with 5/8" x 5" anchors. An optional plate is available that is attached to the barrier bar to prevent the forks from a forklift truck to go under the barrier and damage the overhead door.

This unit is rated to withstand repeated impacts by a 10,000-lb. load moving at 4 mph. Standard units (including stanchion, barrier arm, and receiver pocket) are 12'1" wide.

Customized widths and gusseted models are available to protect the bottom panel of overhead doors. The Bar-Lift Barrier can also be equipped with a self-storing handrail for foot traffic at the dock.

Each Bar Lift Barrier unit and control panel has been factory pre-wired and tested to ensure satisfactory operation.

To illustrate which connections are to be made in the field at installation, electrical drawings are included with each order or by contacting Systems, LLC Technical Services.

Call McGuire to discuss available voltages, phases and options to meet your specific needs.

Technical Service at 800-643-5424 or techservices@loadingdocksystems.com

Component Identification

Inspect package and all components. Report any missing or damaged items immediately and note on the shipping Bill Of Lading (BOL).

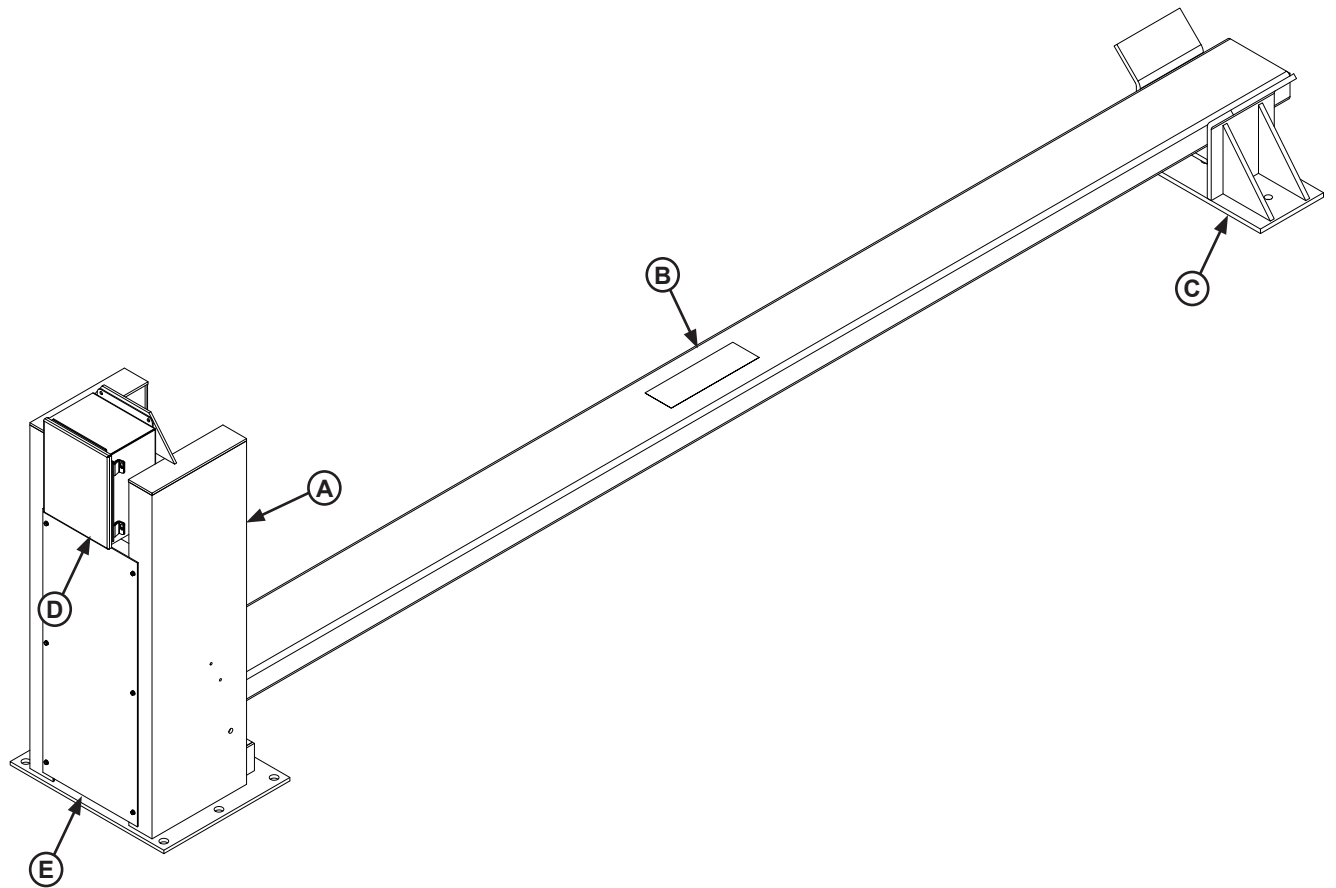

Figure 4

A — Base Assembly
B — Barrier Arm
C — Receiver Assembly

D — Control Box*
E — Rear Sheet Metal Cover

**Control box appearance and location may vary depending on options.*

INSTALLATION

Installation Precautions

DANGER

If it is necessary to service the barrier with the arm in the vertical position, engage a safety chain to prevent the arm from falling.

In addition, it is recommended and good safety practice to use an additional means to support the raised barrier arm. This additional means may include, but is not limited to a boom truck, fork truck, stabilizing bar or equivalent.

NOTICE

DO NOT connect the barrier electrical wiring and ground connections until all welding has been completed.

DO NOT ground welding equipment to any hydraulic or electrical components of the barrier.

Failure to follow these instructions may damage the motor, hydraulics, wiring, and/or control panel.

WARNING

Always post safety warnings and barricade the work area at dock level and ground level to prevent unauthorized use of the equipment before installation is complete.

A hard hat or other applicable head protection should always be worn when working under or around the barrier.

Always stand clear of raised barrier arm when working in front of the barrier.

WARNING

DO NOT grind or weld if hydraulic fluid or other flammable liquid is present on the surface to be ground or welded.

DO NOT grind or weld if uncontained hydraulic fluid or other flammable liquid is present. Stray sparks can ignite spills or leaks near the work area. Always clean up the oil leaks and spills before proceeding with grinding or welding.

Always keep a fire extinguisher of the proper type nearby when grinding or welding.

CAUTION

Only trained installation professionals with the proper equipment should install this product.

Installation

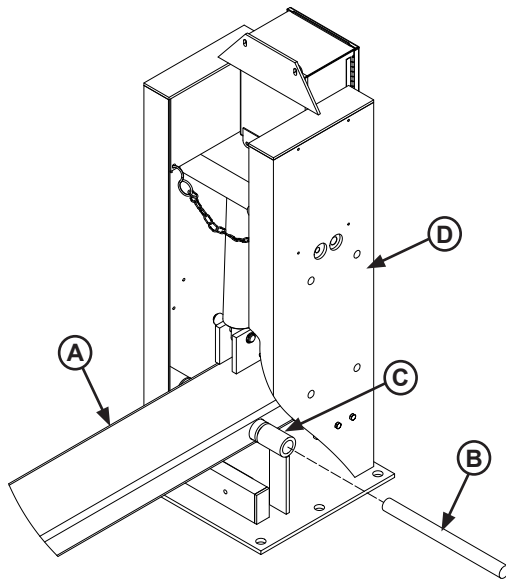

Figure 5

A — Barrier Arm
B — Pivot Pin
C — Main Body
D — Base Assembly

1. Assemble barrier arm (A) into main body (C) with pivot pin (B) provided as shown in Figure 5. Then, lower the pin cover plate and tighten screws to prevent pin movement. At this time, DO NOT connect lift cylinder rod to barrier arm (A).

Note: Removal of rear sheet metal cover from main body may help the assembly process.

2. In order to determine Bar Lift Barrier mounting location, position the barrier so that it is centered in door opening and at least 14" away from the wall (14" wall clearance is required to remove pivot pin).

3. Check overhead clearance with barrier in raised position to ensure that the barrier arm will not interfere with the overhead door or any other overhead objects. See Figure 6.

Note: Standard 10' (3048mm) span barrier requires 12' 2" (3708mm) overhead clearance as shown in Figure 6. Contact Systems, LLC Technical Services for information on non-standard barriers.

4. Check that vertical barrier option (if equipped) is centered over centerline of dock leveler/door opening.

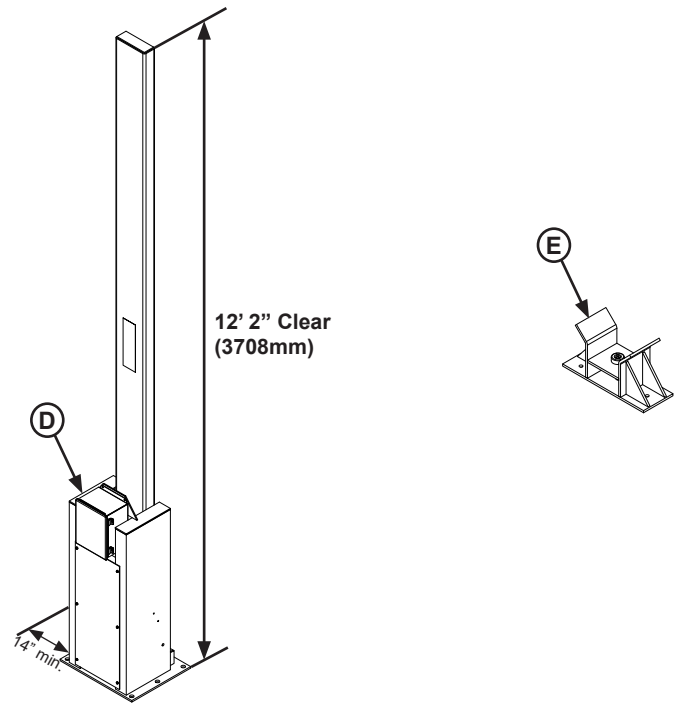

Figure 6

D — Base Assembly
E — Receiver Assembly

5. Using the base assembly (D) as a template, drill six (6) holes for concrete anchors (5/8" x 5" min).

Note: If the floor is not square with respect to the mounting plates, metal shims should be inserted to prevent the plates from twisting during lagging to the floor.

6. Position the base assembly (D) as needed and install six (6) 5/8" x 5" min. concrete anchors.

7. Place the barrier receiver receiver assembly (E) on the opposite side of the main body at desired location.

Note: Do not drill or install concrete anchors for receiver assembly (E) until instructed.

8. Proceed to "Install Control Panel and Wiring" on page 12.

INSTALLATION

Install Control Panel and Wiring

DANGER

Make sure that the power source has been locked out and tagged according to OSHA regulations and approved local electrical codes.

NOTICE

DO NOT connect the barrier electrical wiring and ground connections until all welding has been completed.



DO NOT ground welding equipment to any hydraulic or electrical components of the barrier.

Failure to follow these instructions may damage the motor, hydraulics, wiring, and/or control panel.

CAUTION

All electrical work — including the installation of the disconnect panel, control panel, and final connections to the pit junction box — must be performed by a certified electrician and conform to all local and applicable national codes.

DANGER



Arc Flash and Shock Hazard
PPE [Personal Protection Equipment] Required

De-energize equipment before working on or inside. Do not open cover without appropriate PPE. Refer to NFPA 70E for PPE requirements. This panel may contain more than one power source.

Hazardous Voltage Will Result in Death or Serious Injury

1751-0736 Rev. A

NOTICE

Where indicated, all components must be connected to a SAFETY EARTH GROUND that conforms to the 1999 National Electrical Code Section 250-50 section (a) or section (c) for a grounding electrode system.

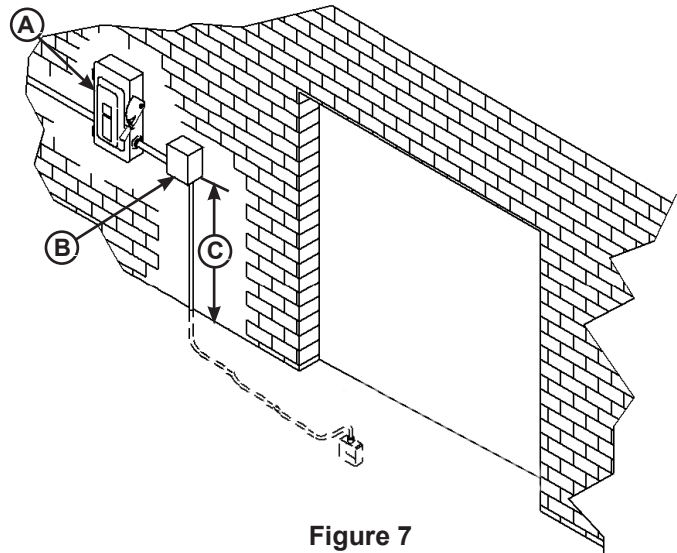

Figure 7

A— Disconnect Panel (provided by others)
B— Control Panel **C— Distance, 48 in. (1219 mm)**

1. For wall-mounted controls, mount the push-button control panel (B) so bottom of control panel-to-dock floor distance (C) is 48 in. (1219 mm). See Figure 7.
2. Install electrical disconnect panel (A) if not already installed. Disconnect panel supplied by others.
3. Install and connect the barrier wiring (see drawings supplied with equipment).

Note: For barrier-mounted controls, saw cut floor from base of wall under supply source to rear of barrier and install 1/2" conduit into trench. Feed electrical line from source to junction box on barrier and connect. Fill trench with epoxy or concrete and level.

4. Seal the conduit in any location where the conduit crosses over temperature zones that could produce condensation.

Optional: Install spacers between the wall and enclosure to provide temperature insulation and air flow. If the conduit could fill with water, a drip leg may be needed.

Put New Barrier Into Service

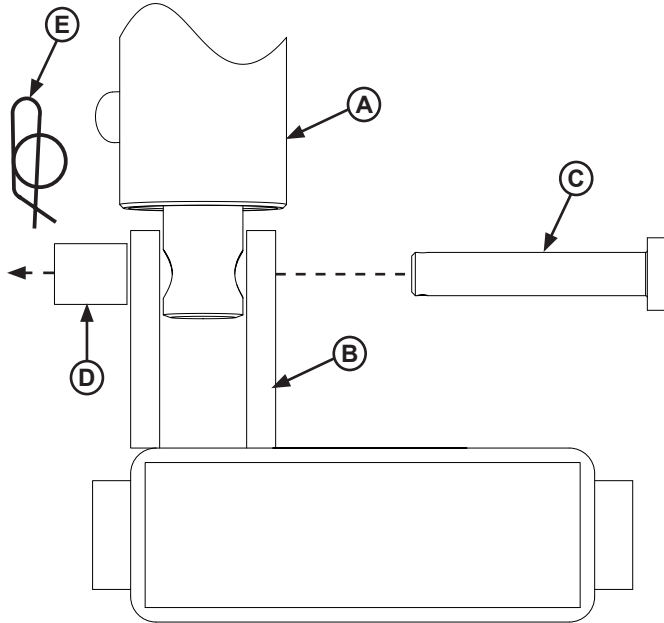

Figure 8

A — Lift Cylinder
B — Barrier Arm
C — Cylinder Pin

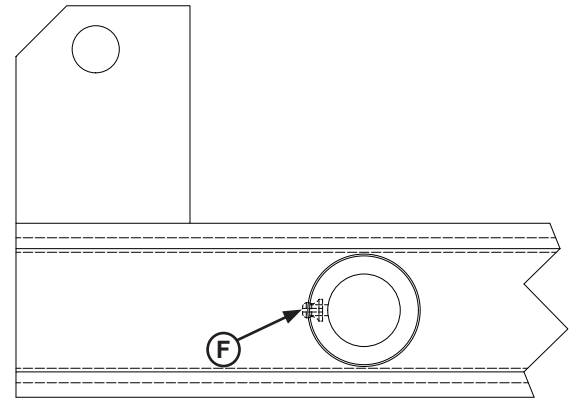

Figure 9

D — Spacer
E — Rue Clip
F — Pivot Pin Grease Fitting

1. Remove pipe plug from filler port on hydraulic fluid reservoir and replace with breather cap provided.
2. Check hydraulic fluid level and add as necessary. See page 18 for required fluid level and type.
3. Turn on power to barrier control panel.
4. If necessary, use control panel to extend lifting cylinder rod. Connect lifting cylinder (A) rod to barrier arm (B) by sliding cylinder pin (C) through the barrier arm, cylinder rod and spacer (D), then secure with rue clip (E). Grease barrier arm pivot pin at pivot tube (F). See Figures 8 and 9.

Note: If rear sheet metal cover was removed from main body during install, reinstall it at this time.

5. Operate barrier up and down several times to ensure proper location of barrier receiver weldment.
6. Once positioned properly with double gusset (single anchor) side towards wall, use the barrier receiver weldment as a template and drill three (3) holes for concrete anchors (5/8" x 5" min.).

Note: If the floor is not square with respect to the mounting plates, metal shims should be inserted to prevent the plates from twisting during lagging to the floor.

7. Position the barrier receiver weldment as needed and install three (3) 5/8" x 5" min. concrete anchors.

8. Test system to verify proper operation:

- Amber light should be off when barrier arm is in the horizontal position (barrier in use) and in the vertical position (barrier stored).
- Pressing the raise button should cause the barrier arm to raise smoothly; releasing the raise button should stop barrier arm motion.
- Pressing the lower button should cause the barrier arm to lower smoothly; releasing the lower button should stop barrier arm motion.

OPERATION

Operational Precautions

DANGER

Stay clear of barrier when transport vehicle is entering or leaving dock area.

DO NOT move or use the barrier if anyone is under or in front of barrier.

Keep hands and feet clear of pinch points. Avoid putting any part of your body near moving parts.

WARNING

Only trained personnel should operate the barrier.

DO NOT use a broken or damaged barrier. Make sure proper service and maintenance procedures have been performed on barrier before using.

DO NOT operate any equipment while under the influence of alcohol or drugs.

DO NOT leave equipment or material unattended on the barrier.

Operating Instructions

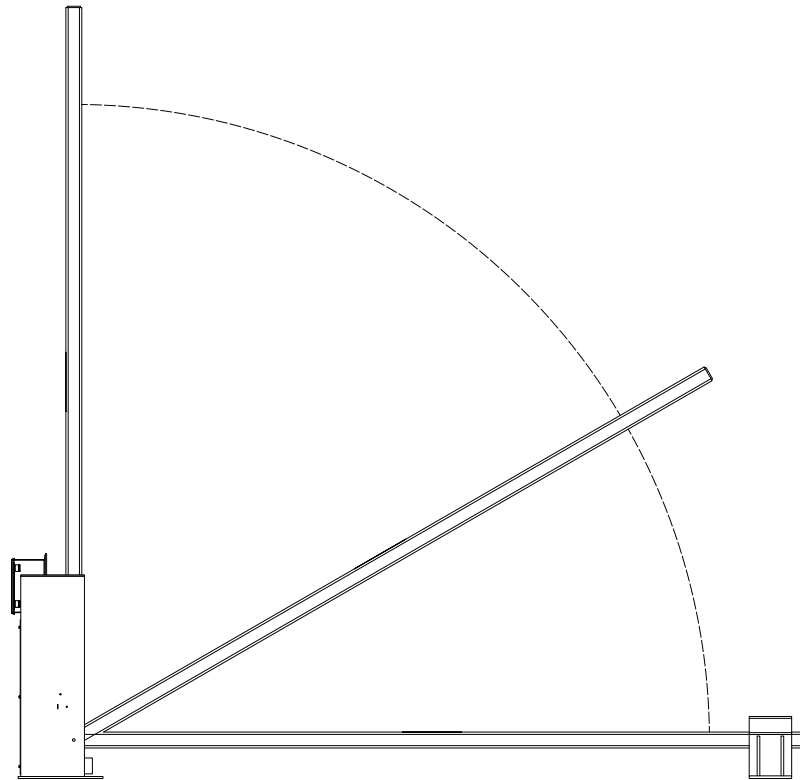

Figure 10

Raising Barrier

1. Visually check path of barrier travel (Figure 10) to make sure it is clear of objects and personnel.
2. Press and hold “RAISE” push button. Amber light will turn on, indicating barrier is mid-travel.
3. When amber light goes “off”, release “RAISE” push button.

Lowering Barrier

1. Visually check path of barrier travel (Figure 10) to make sure it is clear of objects and personnel.
2. Press and hold “LOWER” push button. Amber light will turn on, indicating barrier is mid-travel.
3. When amber light goes “off”, release “LOWER” push button.

Note: The above instructions are for the basic barrier configuration. Some applications will involve interlocking with other equipment such as dock levelers, restraints, overhead doors, or other equipment. Be sure to read the operating instructions supplied with the particular unit.

MAINTENANCE

Maintenance Precautions

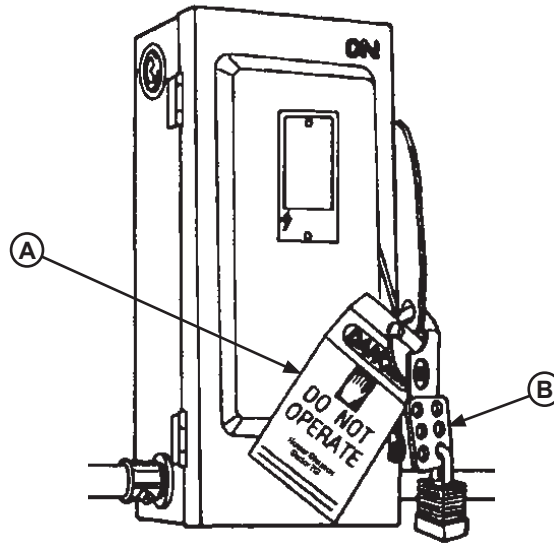

Figure 11

A— Tag Out Device

B—Lock Out Device

DANGER

If it is necessary to service the barrier with the arm in the vertical position, engage a safety chain to prevent the arm from falling.

In addition, it is recommended and good safety practice to use an additional means to support the raised barrier arm. This additional means may include, but is not limited to a boom truck, fork truck, stabilizing bar or equivalent.

When working with electrical or electronic controls, make sure that the power source has been tagged (A) and locked out (B) according to OSHA regulations* and approved local electrical codes (see Figure 11).

Only the person servicing the equipment should have the capability to remove the lockout devices. The tag out devices* must inform that repairs are in process and clearly state who is responsible for the lockout condition.

WARNING



Always post safety warnings and barricade the work area at dock level and ground level to prevent unauthorized use of the equipment before maintenance is complete.

WARNING

A hard hat or other applicable head protection should always be worn when working under or around the barrier.

Always stand clear of the raised barrier arm when working in front of the barrier.

* Refer to OSHA regulations 1910.146. Confined Space and 1910.147. Lockout/Tagout

This page intentionally left blank.

MAINTENANCE

Periodic Maintenance

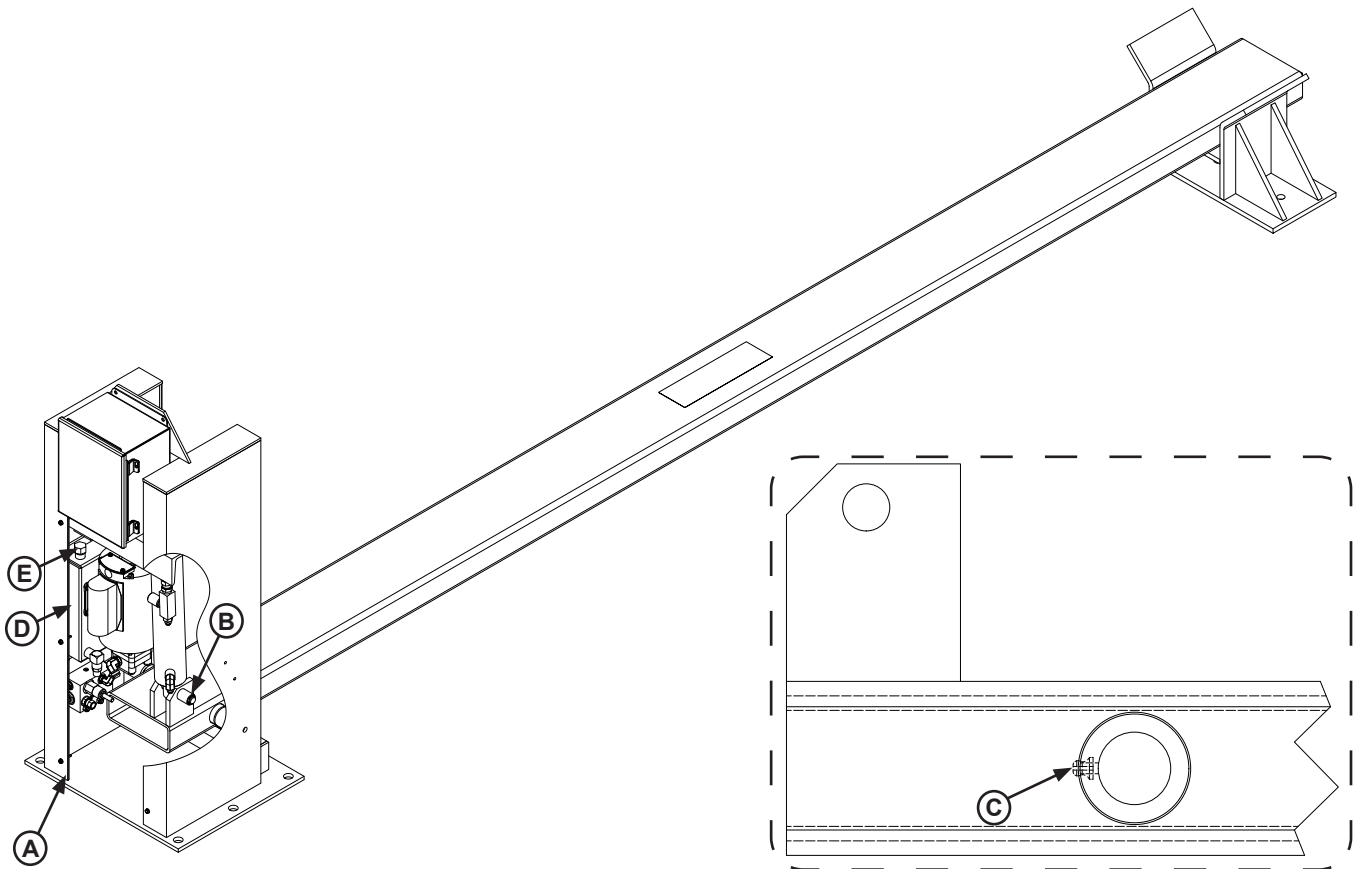

Figure 12

A — Rear Service Panel
B — Cylinder Pin
C — Pivot Pin Grease Fitting

D — Fluid Reservoir
E — Breather Cap

To ensure normal operation of the barrier, use only aircraft hydraulic fluid designed to meet or exceed military specification MIL-H-5606-G. It is recommended that the following hydraulic fluids be used:

- ULTRA-VIS-HVI-15
- Aero Shell Fluid 4 or Fluid 41
- Mobil Aero HFA Mil-H5606A or Aero HF
- Texaco Aircraft Hydraulic Oil 15 or 5606
- Exxon Univis J13
- Castrol Brayco Micronic 756

These fluid brands can be mixed together. Use of hydraulic fluids with equivalent specifications to those listed here are acceptable.

NOTICE

Use of fluids that do not have equivalent specifications to those in the preceding list will result in abnormal operation of the barrier and voiding of warranty.

Weekly Maintenance

- Operate the barrier through the complete operating cycle to maintain lubrication.
- Check that the amber light is on in all positions except fully stored up or down.
- Inspect warning decals and placards. Replace if damaged or missing

Quarterly Maintenance

- Complete Weekly Maintenance.
- Inspect the following for damage/abnormal wear:
 - Check welds for cracks.
 - Cylinder pins and mounting holes.
 - Check J-box for water damage.
 - Inspect hoses, cylinders, fittings and powerpack.
 - Control box and conduit for damage.

Quarterly Maintenance (continued)

- Remove rear service panel (A) and lubricate the hydraulic cylinder pins (B) with light weight machine oil (see Figure 12):
- Lubricate the grease zerk inside the barrier arm (C) white lithium grease (see Figure 12).

NOTICE

Failure to properly lubricate the barrier will cause abnormal operation of the barrier.

- Check reservoir fluid level (see Figure 13):
 1. Put the barrier in the fully lowered position.
 2. Turn OFF all electrical power to the barrier.
 3. Remove rear service panel, then locate fluid reservoir (D).
 4. Remove breather cap (E).
 5. Measure fluid level using the dipstick attached to the breather cap (E). The fluid level should contact the tip of the dipstick approximately 1-1/2 in. (38.1 mm) from top of reservoir with barrier in the lowered position.
 6. Add hydraulic fluid if necessary. Use only recommended fluid (see page 18).
 7. Install breather cap and service panel.
 8. Turn ON electrical power to the leveler.
 9. Return the barrier to service.

Yearly Maintenance

- Complete Quarterly Maintenance.
- Clean or replace fluid filter.
- Change hydraulic fluid (may be required more often depending upon conditions).

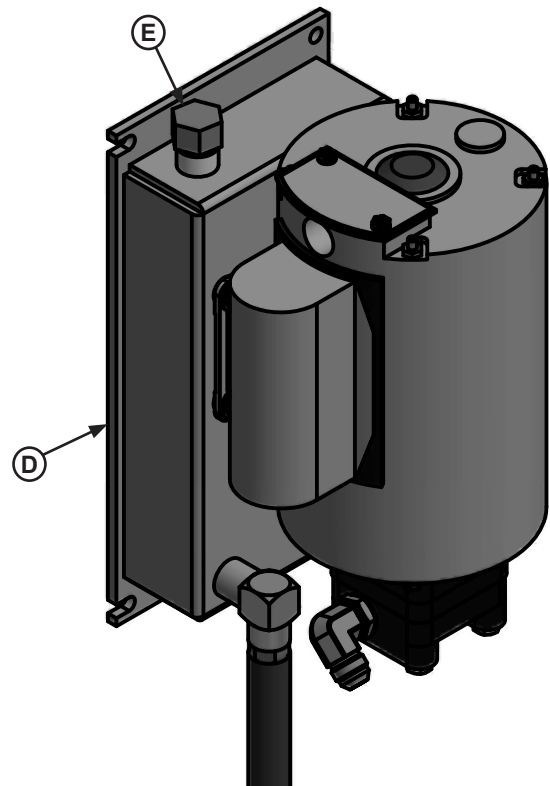

Figure 13
D — Reservoir
E — Breather Cap

ADJUSTMENTS

Adjust Main Pressure Relief

DANGER

If it is necessary to service the barrier with the arm in the vertical position, engage a safety chain to prevent the arm from falling.

In addition, it is recommended and good safety practice to use an additional means to support the raised barrier arm. This additional means may include, but is not limited to a boom truck, fork truck, stabilizing bar or equivalent.

WARNING

When service is required, always lock all electrical disconnects in the OFF position.

Always post safety warnings and barricade the work area at dock level and ground level to prevent unauthorized use of the equipment before maintenance is complete.

A hard hat or other applicable head protection should always be worn when working under or around the barrier.

Always stand clear of the raised barrier arm when working in front of the barrier.

Main Pressure Relief Adjustment

Note: The main pressure relief may need to be *increased* if the barrier does not rise, or rises slowly with the system operating in pressure relief mode.

The main pressure relief may need to be *decreased* if the barrier motor loads down when the barrier arm reaches the full raised position.

See Troubleshooting section on pages 22-25 for more information.

1. Fully lower the barrier arm.
2. Turn OFF all electrical power to the barrier.
3. Loosen jam nut (A).

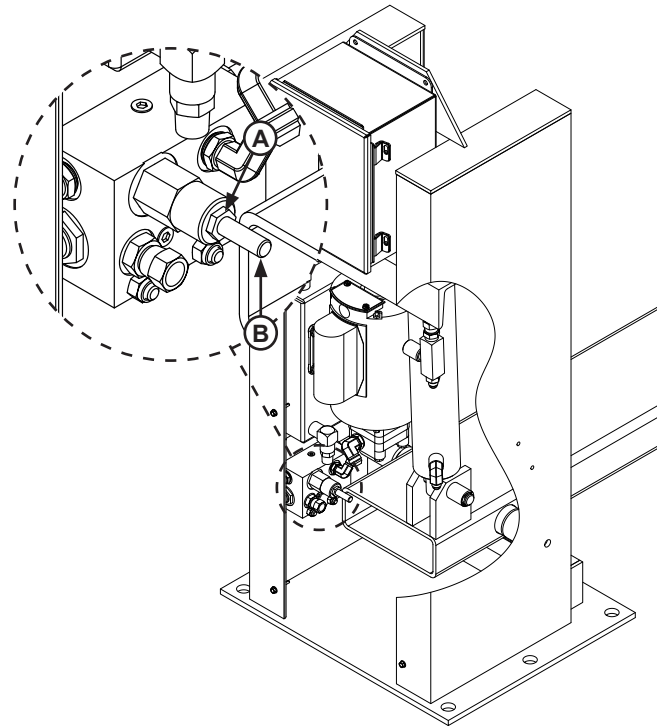

Figure 14

A — Jam Nut

B — Adjusting Screw

4. Adjust adjusting screw (B) as follows:
 - To increase pressure relief, turn adjusting screw clockwise one full turn.
 - To decrease pressure relief, turn adjusting screw counterclockwise one full turn.
5. While holding the adjusting screw (B), tighten jam nut (A).
6. Turn ON electrical power to the barrier.
7. Test barrier and repeat steps 1–6 as necessary.

Adjust Flow Control

Flow Control Adjustment

Note: The down speed flow control is factory set. If original setting is lost, or if the barrier bounces while lowering, the flow control will require adjustment.

When properly adjusted, the barrier arm will smoothly lower from fully raised to fully lowered in 10-12 seconds, without bouncing. To adjust the flow control:

1. Fully lower the barrier arm.
 2. Turn OFF all electrical power to the barrier.
 3. Locate the flow control valve (**C**). Loosen the allen head set screw on the adjusting knob.
 4. Set adjusting knob (**D**) as follows:
 - To decrease the lowering speed, adjust knob clockwise.
 - To increase the lowering speed, adjust knob counterclockwise.
 5. Once ideal down speed flow control setting is achieved, lock the adjustment in place by tightening the hex set screw on the adjustment knob (**D**).
- Note:** Do not overtighten the set screw.
6. Turn ON electrical power to the barrier.
 7. Test barrier and repeat steps 1–6 as necessary.

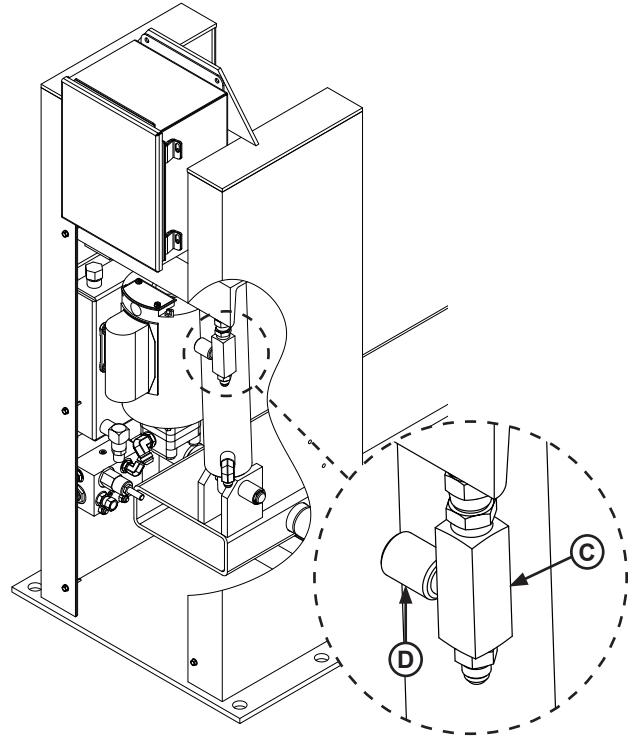

Figure 15

C — Flow Control Valve D — Adjusting Knob

TROUBLESHOOTING

DANGER

If it is necessary to service the barrier with the arm in the vertical position, engage a safety chain to prevent the arm from falling.

In addition, it is recommended and good safety practice to use an additional means to support the raised barrier arm. This additional means may include, but is not limited to a boom truck, fork truck, stabilizing bar or equivalent.

WARNING

When service is required, always lock all electrical disconnects in the OFF position.

Always post safety warnings and barricade the work area at dock level and ground level to prevent unauthorized use of the equipment before maintenance is complete.

A hard hat or other applicable head protection should always be worn when working under or around the barrier.

Always stand clear of the raised barrier arm when working in front of the barrier.

Before performing the detailed troubleshooting procedures, check the following items first:

- Check all fuses inside the control panel(s). Replace any blown fuse(s) with a fuse of equal specification.
- Make sure the correct voltages are present at the proper locations inside the control panel(s).

Symptom	Possible Cause	Solution
Barrier does not raise or lower. Motor does not energize.	Motor overload device tripped.	Reset overload relay or breaker. Determine cause of device tripping.
	Motor starter (three-phase) or motor relay (single-phase) not energizing.	<p>Check voltage at starter or relay coil.</p> <ul style="list-style-type: none"> • If voltage is present and starter or relay does not energize, replace starter or relay. • If voltage is not present, check all components in series with the starter or relay coil.

TROUBLESHOOTING

Symptom	Possible Cause	Solution
<p><u>Three-phase units only:</u> Barrier does not raise or lower. Motor hums, but does not run.</p>	<p>No voltage is present on one line.</p> <p>Note: A motor that is missing voltage on one line is said to be single-phased.</p>	<p>Check for blown fuses at branch circuit disconnect. Replace fuse. Determine cause of blown fuse.</p>
		<p>Check motor starter as follows:</p> <ol style="list-style-type: none"> 1. Disconnect wires at load side of starter. 2. Energize the starter. 3. Measure line-to-line voltage at line side of starter. 4. Measure line-to-line voltage at load side of starter. 5. Line-side and load-side voltages should be approximately the same. Replace starter if voltage values are considerably different from one another.
		<p>Check all wiring to motor for high resistance or no connection.</p>
<p><u>Three-phase units only:</u> Barrier does not raise or lower. Motor runs in reverse</p>	<p>Phase reversed.</p>	<p>Reverse any two legs at the branch circuit disconnect.</p>
<p><u>Single-phase units only:</u> Barrier does not raise or lower. Motor energizes, but does not run.</p>	<p>Line voltage too low.</p>	<p>Check wiring to motor for high resistance. Check for loose or corroded connections. Check if gauge of wires to motor are of correct size and specification for load requirement. Replace if necessary.</p>
	<p>Faulty motor centrifugal switch.</p>	<p>Replace motor.</p>
	<p>Faulty motor capacitor.</p>	<p>Replace motor.</p>

TROUBLESHOOTING

Symptom	Possible Cause	Solution
Barrier will not raise.	Load on barrier arm.	Remove load. Unit is designed to raise no more than its own weight
	4 way valve stuck in "lower" position	<p>Remove coil from cartridge valve and cartridge valve from valve block.</p> <ul style="list-style-type: none"> -Check valve for contaminants and/or damage. -Replace valve if damaged. -Carefully wipe valve with clean rag (do not damage "O" rings on valve). <p>NOTE: Do not over-tighten coil on valve. Max torque is 10 in. lbs. (just over finger tight). Do not over-tighten valve into block. Max torque is 15 ft. lbs. which will compress O-ring and prevent leakage.</p> <p>Operate unit. Replace valve if problem persists after all other troubleshooting procedures.</p>
Barrier will not lower.	Faulty spool valve.	<p>Remove coil from cartridge valve and cartridge valve from valve block.</p> <ul style="list-style-type: none"> -Check valve for contaminants and/or damage. -Replace valve if damaged. -Carefully wipe valve with clean rag (do not damage "O" rings on valve). <p>NOTE: Do not over-tighten coil on valve. Max torque is 10 in. lbs. (just over finger tight). Do not over-tighten valve into block. Max torque is 15 ft. lbs. which will compress O-ring and prevent leakage.</p> <p>Operate unit. Replace valve if problem persists after all other troubleshooting procedures.</p>
	4 way solenoid valve not being energized.	<p>Locate solenoid (see pages 28 & 29). Coil must be energized when barrier is in lowering mode.</p> <p>Check valve for magnetism at the coil.</p>

TROUBLESHOOTING

Symptom	Possible Cause	Solution
Barrier raises very slowly.	Low hydraulic fluid.	Add fluid, see page 18 for proper fluid level and type.
	Pressure relief valve set too low.	Adjust pressure relief. NOTE: <i>The pressure relief valve must not be set at a level that causes the motor operating current to exceed the full load amp value* at any time, including when operating in pressure relief.</i> <i>* The full load amp value can be found on the inside cover of the control panel.</i>
	Damage or blocked hydraulic hose(s) and/or valve(s).	Replace damaged hose(s). Check and remove blockage from hose(s) and/or valve(s).
Barrier bounces while lowering.	Down speed control valve (page 21) set too fast.	Adjust valve, see page 21 for adjustment instructions.
Amber light does not turn on.	Blown bulb.	Replace.
Amber light does not turn off when arm stores vertically.	Upper limit switch not operating.	Adjust or replace switch.
Amber light does not turn off when arm stores horizontally.	Lower limit switch not operating.	Adjust or replace switch.

If additional troubleshooting assistance is required, contact Systems, LLC Technical Services with equipment serial number or customer order number (CO#).

Technical Service at 800-643-5424 or techservices@loadingdocksystems.com

PARTS

Barrier Arm & Receiver

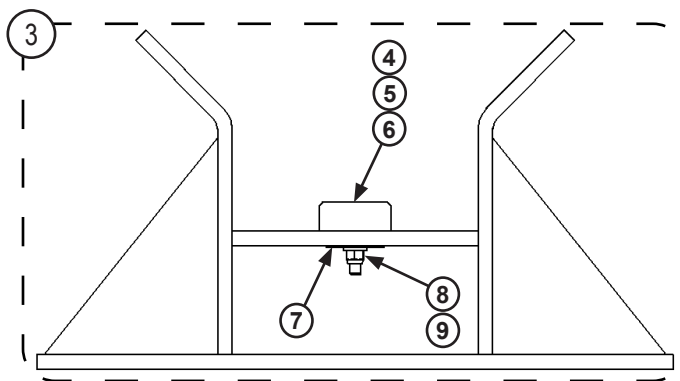
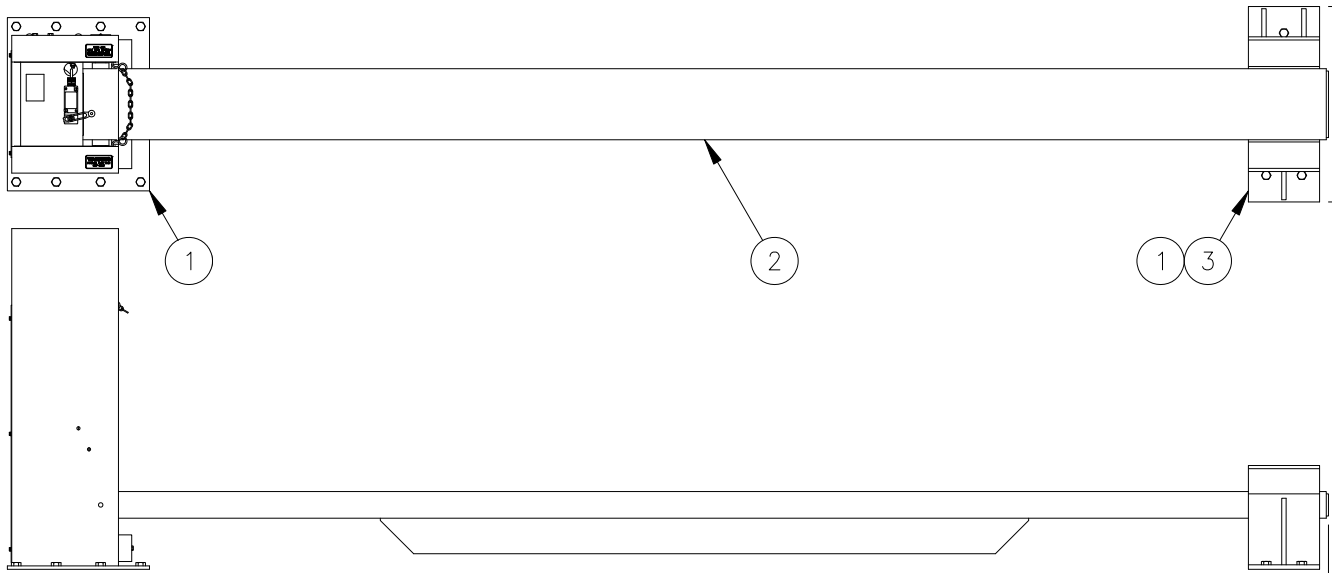

Barrier Arm & Receiver (continued)

Item	Quantity	Part Number	Description
1	11	2101-0108	Concrete Anchor, Rawl, 5/8 x 5
2	1	9445-____*	Barrier Arm Assembly
3	1	9445-0005	Receiver Weldment Assembly (Includes 4-9)
4	1	9951-0005	Rubber Bumper, 2-1/2 Dia x 1
5	1	2101-0089	Hex Head Cap Screw, 3/8-16 UNC x 2
6	1	2101-0060	Washer, Flat, Zinc Plated, 3/8" Dia
7	1	2101-0132	Washer, Fender, 1/2" Dia
8	1	2101-0079	Washer, Flat, Zinc Plated, 1/2" Dia
9	1	2101-0040	Nylon Lock Nut, 3/8-16 UNC x 2

* Provide barrier arm serial number, voltage, phase, and options when e-mailing, calling or faxing orders.

PARTS

Base Assembly

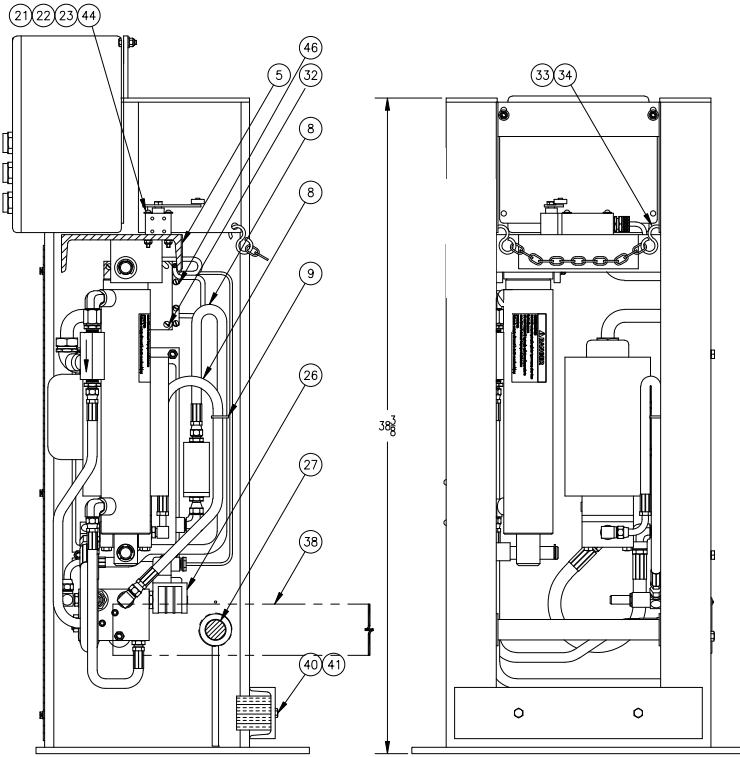

SECTION "B-B"

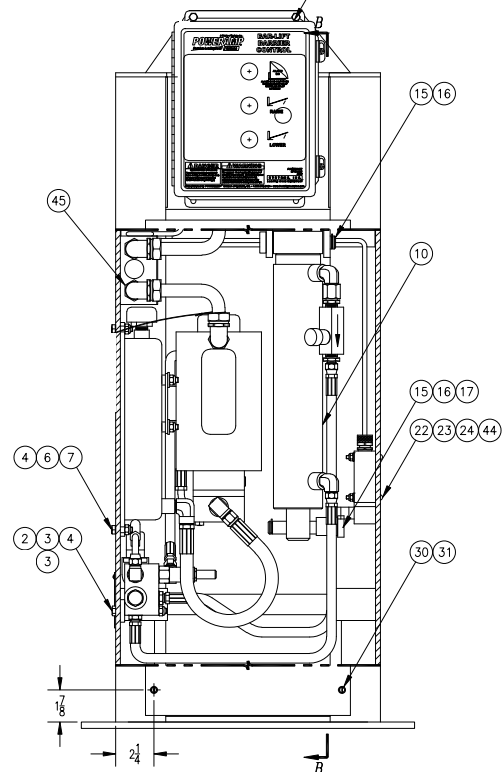
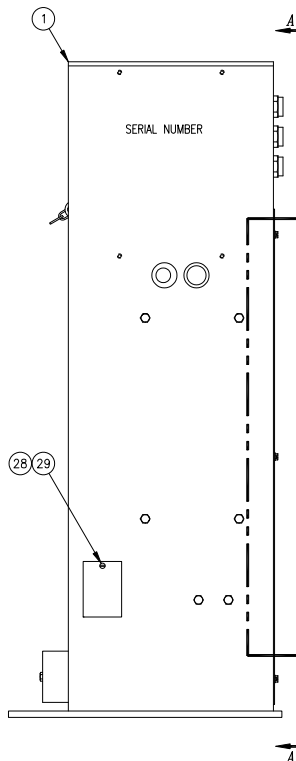
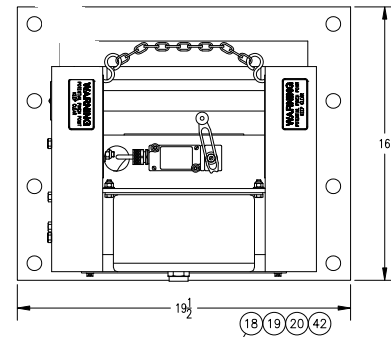

SECTION "A-A"

Base Assembly (continued)

Item	Quantity	Part Number	Description
1	1	9445-0006	Base Weldment
2	1	8583-0043	Valve Assembly
3	2	2101-0077	Hex Head Cap Screw, 5/16-18 UNC x 3
4	6	2101-0039	Nut, Nylon Lock, 5/16-18 UNC
5	1	0191-0018	Rubber Weatherseal
6	1	See Page 30	Powerpack Assembly, Complete
7	4	2101-0187	Hex Head Cap Screw, 5/16-18 UNC x 1
8	2	9904-0079	Hydraulic Hose, 1/4"100R1 x 28", #6 JICF Swivel Both Ends
9	1	3051-0033	Wire Tie - 7-1/2"
10	1	0525-0075	Cylinder Assembly
15	2	9202-0071	Pin, .746" Diameter x 4.44" Headed Pin
16	2	2101-0259	Ring, Rue, 3.4 STD
17	1	9442-0027	Spacer, 3/4 Sch. 40 x 1-1/4
18	1	*	Control Box, B2 Barrier*
19	2	2101-0084	Hex Head Cap Screw,
20	2	2101-0059	Washer, Flat, 1/4
21	1	0615-0043	Limit Switch Assembly, Upper
22	4	2101-0374	Round Head Machine Screw, Torx, #10-24 UNC x 2.5
23	4	2101-0151	Nut, Nylon Lock, #10-24 UNC
24	1	0615-0044	Limit Switch Assembly, Lower
26	1	4305-0180	Cable Assembly, Wiring Harness
27	1	9442-0026	Pin, 1-3/16 x 14
28	1	2101-0026	Pan Head Machine Screw - Self Tap, #8-32 UNC x 1
29	1	9411-0001	Access Cover - Pin
30	1	9441-0002	Access Cover - Main
31	6	2101-0105	Hex Head Cap Screw - Self Tap, #12-24 UNC 1-1/4
32	1	2751-0016	Cover - J-Box, 4 x 4
33	1	9442-0032	#2 Chain - St. Link - 10" Lg.
34	2	4261-0002	Hook - "S", Wire .220 - 2-1/8
38	1	*	Barrier Arm Assembly*
40	1	9952-0012	Pad - Rubber, 2 x 2 x 9
41	2	2101-0186	Hex Head Lag Screw, 1/4 x 1-1/4
42	2	2101-0143	Nut, Nylon Lock, 1/4-20 UNC
43	1	8581-0004	Coil, Delta
44	1	4305-0235	Cable Assembly, 1 Coil - 48" Long
45	4	2101-0370	Washer, #10
46	1	1431-0012	Connector, Cord, Screw Clamp

* Provide barrier arm serial number, voltage, phase, and options when e-mailing, calling or faxing orders.

PARTS

Powerpack Assembly

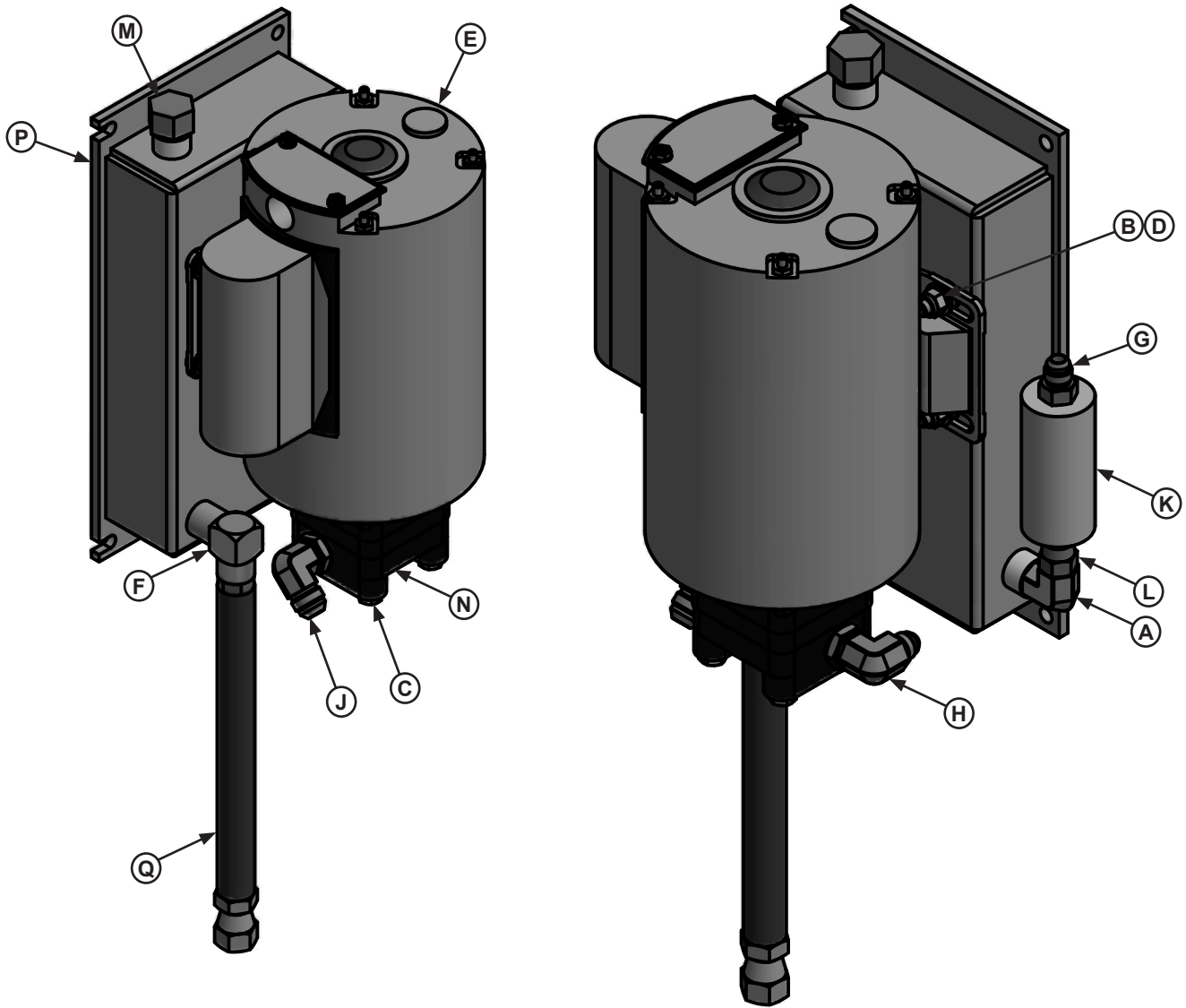

Powerpack Assembly (continued)

Item	Quantity	Part Number	Description
*	1	9395-0086*	Powerpack Assembly, B2, 1-Phase (Includes A-Q)*
*	1	9395-0087*	Powerpack Assembly, B2, 3-Phase (Includes A-Q)*
A	1	0521-0044	Fitting, Elbow, 90 Deg, 3/8NPTM, #6 JICM
B	4	2101-0039	Nylon Lock Nut, 5/16-18 UNC
C	4	2101-0077	Hex Head Cap Screw, 5/16-18 UNC
D	4	2101-0163	Washer, Flat, Zinc Plated, 5/16" Dia.
E	1	3411-0008	Motor, 1-Phase, 115/230V
		3411-0019	Motor, 3-Phase, 208-230/460V
F	1	9301-0007	Fitting, Elbow, 90 Deg, Street, 3/8 NPTM x 3/8 NPTF
G	1	9301-0109	Fitting, Con, Str. Thrd, #6 ORB - #6 JIC
H	1	9301-0114	Fitting, Elbow, 90 Deg. Str. Thread, #8 ORB - #6 JIC
J	1	9301-0116	Fitting, Elbow, 90 Deg. Str. Thread, #8 ORB - #8 JIC
K	1	9301-0121	Filter, Inline, SAE #6
L	1	9301-0123	Fitting, Conn, Str. Thread, Swivel, #6 ORB - #6 JICF SW
M	1	9301-0199	Breather Cap w/Dipstick, 3/8 NPT
N	1	9301-0268	Pump, 1.75 GPM, MTE
P	1	9303-0010	Reservoir Weldment
Q	1	9904-0041	Hyd Hose, 1/2"100R17,11.00LG, 3/8 NPTM / #8 JICF Swivel

* Provide barrier arm serial number, voltage, phase, and options when e-mailing, calling or faxing orders.

PARTS

Cylinder Assembly

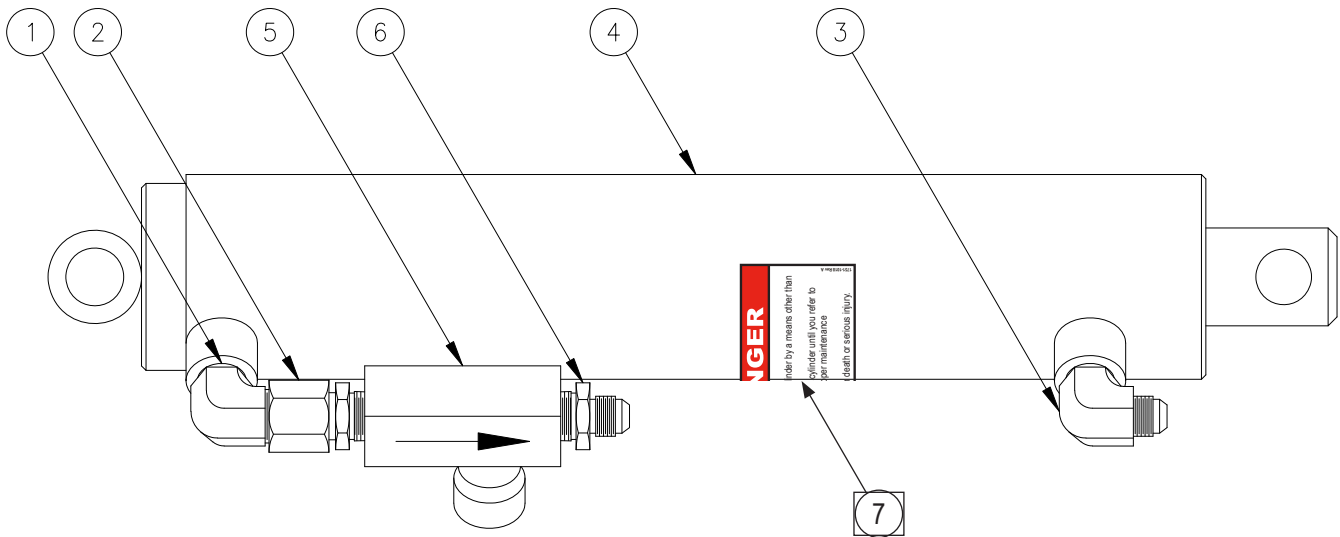

Cylinder Assembly (continued)

Item	Quantity	Part Number	Description
*	1	0525-0075	Cylinder Assembly, B2 Barrier (Includes 1-6)
1	1	0521-0017	Fitting, Elbow, 90 Deg. Male, 3/8 NPT x #8 JIC
2	1	0521-0032	Fitting, Conn, Swivel, 3/8 NPT x #8 JIC Swivel
3	1	0521-0044	Fitting, Elbow, 90 Deg. Male, 3/8 NPT x #6 JIC
4	1	0525-0065	Cylinder Subassembly
5	1	8581-0012	Valve - Flow Control - Fine Adjust
6	1	9301-0143	Fitting, Conn, Male, 3/8 NPT x #6 JIC
7	1	1751-1018	Decal, Cylinder

PARTS

Valve Assembly

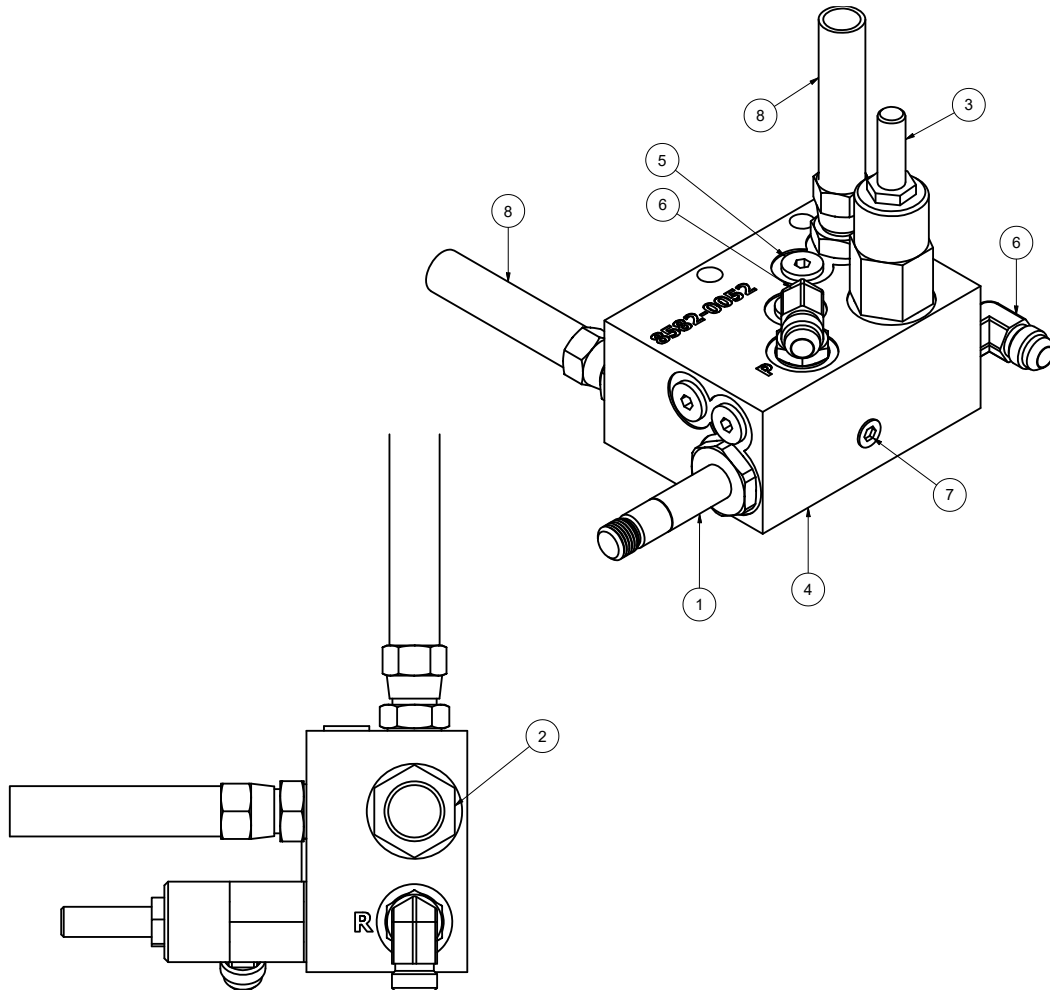

Valve Assembly (continued)

Item	Quantity	Part Number	Description
*	1	8583-0043	Valve Assembly, B2 Barrier (Includes 1-7)
1	1	8581-0011	Cartridge Valve - 4-Way
2	1	8581-0081	Valve, Cart, Check, Pilot Operated
3	1	8581-0187	Valve, Cart, Relief
4	1	8582-0052	Manifold, Hydraulic Valve, B2
5	5	9301-0104	Hollow Hex Plug-ST #4 ORB
6	2	9301-0113	Fitting, Elbow - 90 Deg, Str Thread, #6 ORB - #6 JIC
7	6	9571-0007	Fitting, Plug, 1/8 NPTM
8	2	9904-0080	Hyd. Hose, 1/4"100R17,25.00 LG, #6 SAE ORB / #6 JICF Swivel

PARTS

Solenoid Coil, Harness, & Limit Switches

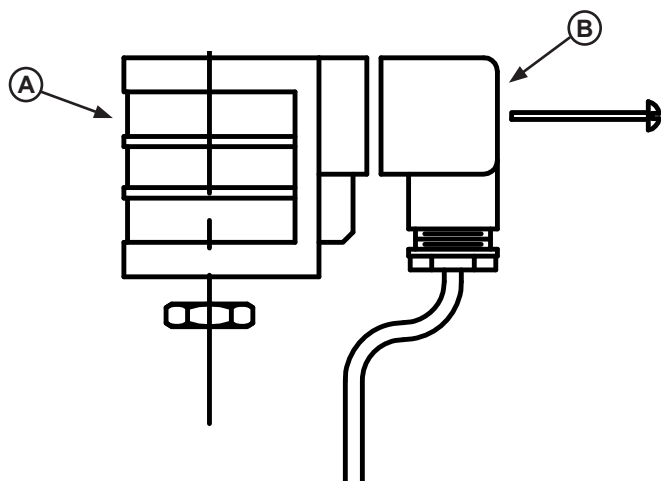

Item	Quantity	Part Number	Description
A	1	8581-0004	Coil, Delta
B	1	4305-0235	Cable Assembly, 1 Coil - 48" Long

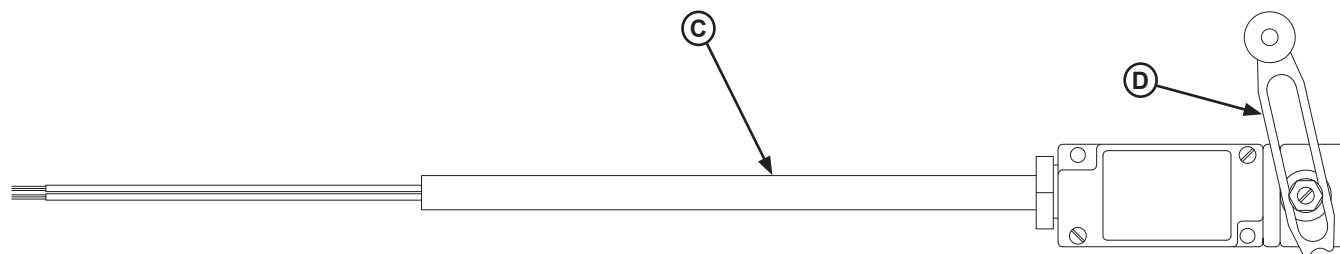

Item	Quantity	Part Number	Description
	*	0615-0043	Complete Upper Limit Switch Assembly
C	1	0961-0666	Limit Switch with Cable
D	1	0961-0667	Lever, Upper Switch

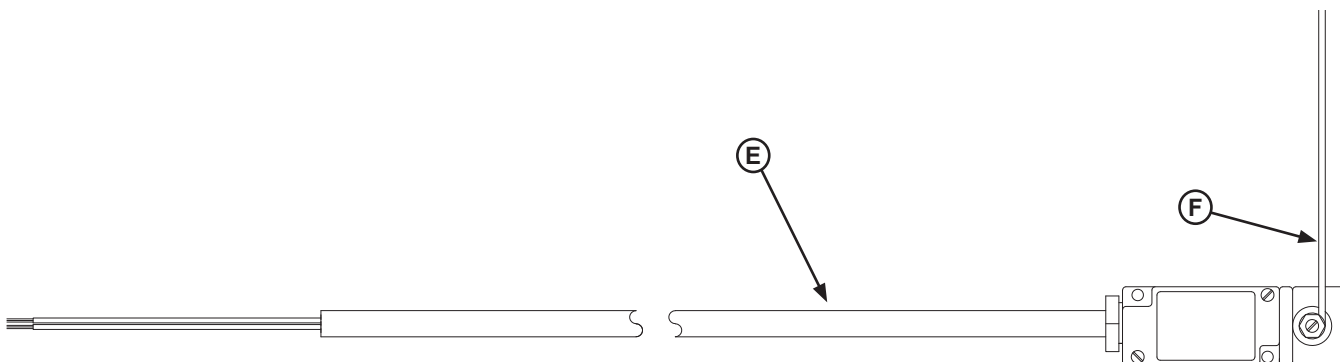

Item	Quantity	Part Number	Description
*	*	0615-0044	Complete Lower Limit Switch Assembly
E	1	0961-0666	Limit Switch with Cable
F	1	961-0668	Lever, Lower Switch

Customer Information

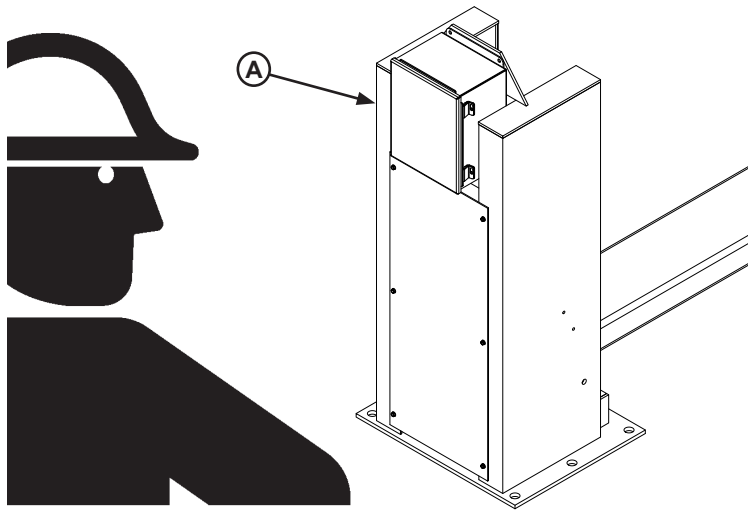

Figure 16

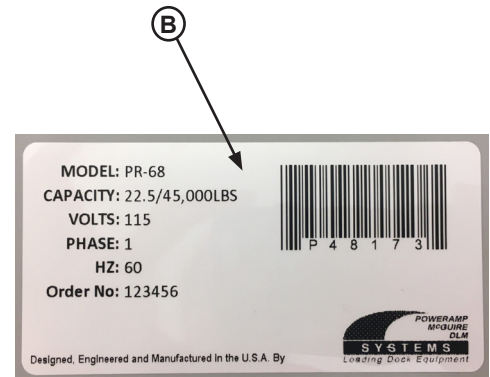

Figure 17

NOTE: Refer to Figure 16 for left/right orientation of barrier base and Figure 17 for example of decal.

The BARRIER model/serial number decal is located on the left side of the base assembly (A).

When you receive your new equipment, write down the model and serial number in the form provided. This will help ensure safe keeping of the numbers in the event the model/serial number decal (A, B) becomes lost or damaged.

Also, write down Systems, LLC's order number, the company that installed the equipment, and the original owner's name. This will all help to identify the specific equipment if more information is required.

When ordering, use part numbers and description to help identify the item ordered. Do not use "item" numbers. These are only for locating the position of the parts. Always give MODEL NUMBER and/or SERIAL NUMBER.

For service, call or contact:

Systems, LLC
P.O. Box 309
Germantown, WI 53022

Phone: (800) 643-5424
Fax: (262) 255-5917

www.loadingdocksystems.com

Dock Leveler Information

Model _____

Serial No. _____

Systems, LLC, Job No. _____

Vehicle Restraint Information

Model _____

Serial No. _____

Systems, LLC Order No. _____

Original Owner Information

Name _____

Address _____

Installer Information

Name _____

Address _____

Date of Installation _____

STANDARD PRODUCT WARRANTY

SYSTEMS, LLC warrants that its products will be free from defects in design, materials and workmanship for a period of one (1) year from the date of shipment. All claims for breach of this warranty must be made within 30 days after the defect is or can with reasonable care, be detected. In no event shall any claim be made more than 30 days after this warranty has expired. In order to be entitled to the benefits of this warranty, the product must have been properly installed, maintained and operated in accordance with all manufacturer's recommendations and/or specified design parameters and not otherwise have been subject to abuse, misuse, misapplication, acts of nature, overloading, unauthorized repair or modification, application in a corrosive environment or lack of maintenance. Periodic lubrication, adjustment and inspection in accordance with all manufacturers' recommendations are the sole responsibility of the Owner/User.

In the event of a defect, as determined by SYSTEMS LLC, covered by this warranty, SYSTEMS LLC shall remedy such defect by repairing or replacing any defective equipment or parts, bearing the cost for the parts, labor and transportation. This shall be exclusive remedy for all claims whether based on contract, negligence or strict liability.

WARRANTY LIMITATIONS

THE ABOVE WARRANTIES ARE IN LIEU OF ANY OTHER WARRANTIES, WHETHER EXPRESSED OR IMPLIED, INCLUDING BUT NOT LIMITED TO ANY IMPLIED WARRANTY OF MERCHANTABILITY OR FITNESS FOR A PARTICULAR PURPOSE. SYSTEMS LLC AND ITS SUBSIDIARIES SHALL NOT IN ANY EVENT BE LIABLE TO ANYONE, INCLUDING THIRD PARTIES, FOR INCIDENTAL, CONSEQUENTIAL OR SPECIAL DAMAGES OF ANY KIND INCLUDING BUT NOT LIMITED TO, BREACH OF WARRANTY, LOSS OF USE, LOSS OF PROFIT, INTERRUPTION OF BUSINESS OR LOSS OF GOODWILL.